

GMG PLUS

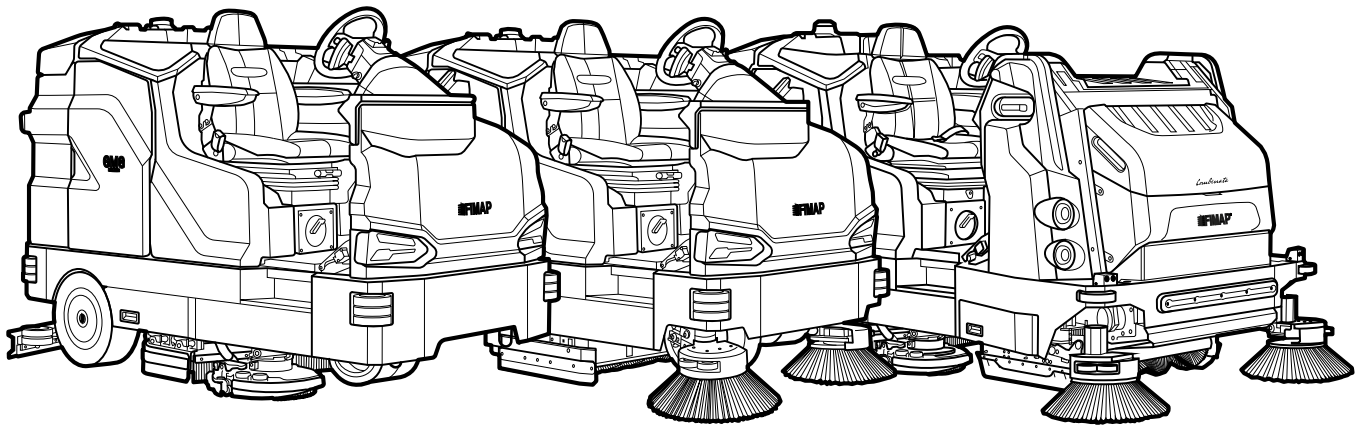

PROFESSIONAL SCRUBBING MACHINES

USE AND MAINTENANCE MANUAL

 **FIMAP**[®]



ORIGINAL INSTRUCTIONS DOC. 10111413 - Ver. AB - 06-2023

The constructive elements and content of this manual, including the structure, text, diagrams, images and logo, are the exclusive property of FIMAP S.P.A.. They are protected, both collectively and individually, by the current regulations regarding intellectual property (including copyright laws), and cannot be either wholly or partially copied or imitated. Any reproduction, reprocessing, distribution or dissemination is strictly prohibited.





CONTENTS

CONTENTS	3
DEFINITION OF LEVELS OF WARNING	6
GENERAL SAFETY REGULATIONS	6
GENERAL DESCRIPTION	7
SYMBOLS USED IN THE MANUAL.....	7
TECHNICAL DESCRIPTION.....	8
INTENDED USE - PLANNED USE (TYPE OF SCRUBBING-DRYING WORK).....	8
INTENDED USE - PLANNED USE (TYPE OF SWEEPING WORK).....	9
SERIAL NUMBER PLATE.....	9
MAIN MACHINE COMPONENTS	10
TECHNICAL DATA	15
SYMBOLS USED ON THE MACHINE	17
LABELS USED ON THE MACHINE	20
CONTROL STATION	29
MEMBRANE PUSH-BUTTON PANEL FOR MOVING THE DEBRIS HOPPER (COMBINED VERSION).....	29
CONTROL PUSH-BUTTON PANEL.....	30
MEMBRANE PUSH-BUTTON PANEL FOR ACTIVATING WORKING PROGRAMS.....	30
CONTROL DISPLAY.....	31
TOUCH SCREEN.....	32
PREPARATION OF MACHINE	33
HANDLING THE PACKAGED MACHINE.....	33
HOW TO UNPACK THE MACHINE.....	33
MACHINE SAFETY.....	35
HOW TO MOVE THE MACHINE.....	37
HOW TO MOVE THE MACHINE WITH THE TRACTION IN NEUTRAL.....	40
TRACTION ELECTRIC BRAKE ACTIVATION.....	41
TYPE OF BATTERY PACK TO BE USED.....	42
BATTERY BOX MAINTENANCE AND DISPOSAL.....	42
INSERTING THE BATTERY BOX IN THE MACHINE.....	42
RECHARGING THE BATTERY BOX.....	42
ADJUSTMENT OF THE DRIVER'S SEAT (STANDARD SEAT).....	44
ADJUSTMENT OF THE DRIVER'S SEAT (COMFORT SEAT).....	44
INSERTING WATER SYSTEM FILTER.....	45
DETERGENT SOLUTION.....	46
ASSEMBLY OF BRUSHES OR DRIVE DISCS (DISCOID SCRUBBING VERSION).....	49
ASSEMBLING THE ABRASIVE PAD (DISCOID SCRUBBING VERSION).....	52
ASSEMBLY OF THE SIDE BRUSH HEAD BRUSH OR DRIVE DISCS (DISCOID SCRUBBING VERSION).....	53
ASSEMBLING THE SIDE BRUSH HEAD ABRASIVE PAD (DISCOID SCRUBBING VERSION).....	53
FITTING OF BRUSHES (CYLINDRICAL SCRUBBING VERSION).....	54
ASSEMBLY OF THE SIDE BRUSHES (CYLINDRICAL - COMBINED SCRUBBING VERSION).....	56
ASSEMBLY OF BRUSHES (COMBINED VERSION).....	57
WORK PREPARATION CHECKLIST	59
WORKING PROGRAMS	62
ECO MODE WORKING PROGRAM.....	63
COMFORT MODE WORKING PROGRAM.....	64
DYNAMIC MODE WORKING PROGRAM.....	65
HEAVY MODE WORKING PROGRAM.....	66
ZONE MODE WORKING PROGRAM.....	67
MANUAL MODE WORKING PROGRAM.....	68
POWER MODE WORKING PROGRAM.....	69
WORKING MODE	70
DS SELECTOR (DRIVE SELECT).....	70
STARTING WORK	71
HOUR METER.....	76
BATTERY BOX CHARGE LEVEL INDICATOR.....	77

SOLUTION TANK FILL LEVEL INDICATOR	78
OVERFLOW DEVICE	78
EMPTYING THE DEBRIS HOPPER (CYLINDRICAL VERSION).....	79
EMPTYING THE DEBRIS HOPPER (COMBINED VERSION).....	80
ADDITIONAL FUNCTIONS	82
ADJUSTING THE PRESSURE EXERTED ON THE BRUSH HEAD	82
REGULATING THE FORWARD SPEED.....	83
ADJUSTMENT OF THE DETERGENT SOLUTION FLOW	84
VACUUM SYSTEM PERFORMANCE ADJUSTMENT (SCRUBBING VERSION)	85
VACUUM SYSTEM DEBRIS HOPPER PERFORMANCE ADJUSTMENT (COMBINED VERSION).....	86
SERVICE FUNCTION	86
BRUSH UNCOUPLING FUNCTION (DISCOID SCRUBBING VERSION)	87
BUZZER	87
SERVICE LIGHTS	87
EMERGENCY BUTTON.....	88
BRAKING CONTROL.....	89
REVERSE GEAR	89
ANTI-COLLISION SYSTEM	91
SMART DRYING MODE	92
WORKING HEADLIGHTS	92
ALARM SCREEN	93
REAR VIEW CAMERA	94
USAGE DATA.....	95
TUTORIAL.....	97
SIDE BRUSH (COMBINED VERSION)	98
OPTIONAL FUNCTIONS	99
SOS DEVICE	99
USB PORT	99
BLUE SAFETY LIGHT.....	100
RECOVERY TANK SPRAY CLEANING GUN.....	100
LIQUID VACUUM WAND	102
FFM - TAG INSERTION	103
SIDE BRUSH (DISCOID SCRUBBING VERSIONS).....	104
SIDE BRUSH (CYLINDRICAL SCRUBBING VERSION).....	105
FLR - CONTINUOUS RECYCLING SYSTEM	106
FSS - AUTOMATIC DETERGENT DOSING SYSTEM	107
AT THE END OF THE WORK.....	108
MAINTENANCE PLAN	109
DAILY MAINTENANCE	110
WEEKLY MAINTENANCE.....	111
MONTHLY MAINTENANCE	112
MAINTENANCE PRIOR TO EXTENDED PERIODS OF DOWNTIME	113
ROUTINE MAINTENANCE.....	115
CLEANING THE SQUEEGEE.....	116
CLEANING THE SQUEEGEE VACUUM HOSE	117
CLEANING THE COLLECTION FILTER TRAY.....	119
CLEANING THE WAVE PROTECTION TRAY	120
DRAINING THE RECOVERY TANK	121
CLEANING THE WATER SYSTEM FILTER	123
EMPTYING THE SOLUTION TANK.....	123
CLEANING THE FILTER ON THE AUTOMATIC CHEMICAL DETERGENT MANAGEMENT SYSTEM (FSS VERSION).....	124
EMPTYING OF CHEMICAL DETERGENT TANK (FSS VERSION)	124
CLEANING THE FILTER ON THE DETERGENT SOLUTION RECYCLING SYSTEM (FLR VERSION).....	125
CLEANING OF BRUSH HEAD DRIVE BRUSH - DISC (DISCOID SCRUBBING VERSIONS).....	126
CLEANING OF BRUSH HEAD SIDE SPLASH GUARD (DISCOID SCRUBBING VERSION).....	128
CLEANING OF SIDE BRUSH HEAD DRIVE BRUSH - DISC (DISCOID SCRUBBING VERSION).....	128
CLEANING OF SIDE BRUSH HEAD SPLASH GUARD (DISCOID SCRUBBING VERSION).....	129

CLEANING OF SIDE BRUSH HEAD SQUEEGEE (DISCOID SCRUBBING VERSION).....	130
CLEANING OF BRUSH HEAD BRUSH (CYLINDRICAL SCRUBBING VERSIONS).....	131
CLEANING OF BRUSH HEAD SIDE SPLASH GUARD (CYLINDRICAL SCRUBBING VERSION).....	132
CLEANING THE DEBRIS HOPPER (CYLINDRICAL SCRUBBING VERSION).....	132
CLEANING THE SIDE BRUSH (CYLINDRICAL - COMBINED SCRUBBING VERSION).....	133
CLEANING THE BRUSH HEAD BRUSHES (COMBINED VERSION).....	135
CLEANING THE DEBRIS HOPPER VACUUM FILTER (COMBINED VERSION).....	136
CLEANING THE DEBRIS HOPPER (COMBINED VERSION).....	137
EXTRAORDINARY MAINTENANCE WORK	140
REPLACEMENT OF BRUSH HEAD DRIVE BRUSHES OR DISCS (DISCOID SCRUBBING VERSION)	141
REPLACEMENT OF BRUSH HEAD SIDE SPLASH GUARD (DISCOID SCRUBBING VERSION)	143
REPLACEMENT OF SIDE BRUSH HEAD DRIVE BRUSH OR DISCS (DISCOID SCRUBBING VERSION)...	144
REPLACEMENT OF SIDE BRUSH HEAD SPLASH-GUARD RUBBER BLADE (DISCOID SCRUBBING VERSION).....	144
REPLACEMENT OF SIDE BRUSH HEAD SQUEEGEE RUBBER BLADES (DISCOID SCRUBBING VERSION).....	145
REPLACING THE SQUEEGEE RUBBER BLADES	146
REPLACING THE BRUSH HEAD BRUSHES (CYLINDRICAL SCRUBBING VERSION).....	148
REPLACEMENT OF BRUSH HEAD SIDE SPLASH GUARD (CYLINDRICAL SCRUBBING VERSION).....	148
REPLACEMENT OF THE SIDE BRUSH (CYLINDRICAL-COMBINED SCRUBBING VERSION).....	150
REPLACING THE SWEEPING BRUSH HEAD BRUSHES (COMBINED VERSION).....	151
ADJUSTMENT INTERVENTIONS	153
ADJUSTING THE SQUEEGEE RUBBER BLADES.....	153
ADJUSTMENT OF BRUSH HEAD SIDE SPLASH GUARD (DISCOID SCRUBBING VERSION).....	156
ADJUSTMENT OF BRUSH HEAD SIDE SPLASH GUARD (CYLINDRICAL SCRUBBING VERSION)	157
ADJUSTMENT OF THE SIDE BRUSH (CYLINDRICAL SCRUBBING VERSION).....	159
ADJUSTING THE SIDE BRUSH (COMBINED VERSION).....	160
DISPOSAL	162
CHOOSING AND USING BRUSHES	163
BRUSHES OR DRIVE DISCS (DISCOID SCRUBBING VERSION).....	164
BRUSHES OR DRIVE DISCS (CYLINDRICAL SCRUBBING VERSION).....	165
BRUSHES OR DRIVE DISCS (COMBINED VERSION).....	166
TROUBLESHOOTING	167
THE MACHINE DOES NOT START.....	167
THE BATTERY BOX IS NOT COMPLETELY CHARGED.....	167
THE MACHINE HAS A VERY LOW WORK AUTONOMY.....	167
THE MACHINE DOES NOT MOVE	168
INSUFFICIENT DETERGENT SOLUTION ON THE BRUSHES	168
THE MACHINE DOES NOT CLEAN CORRECTLY	168
THE SQUEEGEE DOES NOT DRY CORRECTLY	170
EXCESSIVE FOAM PRODUCTION	171
THE MACHINE DOES NOT VACUUM CORRECTLY.....	171
EXCESSIVE DUST PRODUCTION (COMBINED VERSION).....	171
EC DECLARATION OF CONFORMITY.....	172
UKCA DECLARATION OF CONFORMITY	174

DEFINITION OF LEVELS OF WARNING

-  **DANGER:** indicates an imminent dangerous situation that, unless avoided, will result in death or serious injuries.
-  **WARNING:** Indicates a potentially dangerous situation that, unless avoided, could cause death or serious injury.
-  **ATTENTION:** Indicates a potentially dangerous situation that, unless avoided, could cause slight or moderate injuries.
-  **N.B.:** instructs the reader to pay particular attention to the topic that follows.

GENERAL SAFETY REGULATIONS

Before using the machine, please read the following document carefully and follow the instructions contained herein, along with the instructions in the document supplied with the machine itself, "GENERAL SAFETY REGULATIONS" (document number 10083659).

GENERAL DESCRIPTION

The descriptions contained in this document are not binding. The company therefore reserves the right to make any modifications at any time to elements, details, or accessory supply, as considered necessary for reasons of improvement or manufacturing/commercial requirements. The reproduction, even partial, of the text and drawings contained in this document is prohibited by law.

The company reserves the right to make any technical and/or supply modifications. The images are for reference purposes only, and are not binding in terms of design and supply.

SYMBOLS USED IN THE MANUAL

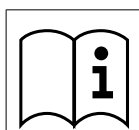

Open book symbol with an "i":
Indicates the need to consult the instruction manual.



Open book symbol:
Tells the operator to read the user manual before using the device.



Covered place symbol:
The operations preceded by this symbol must always be carried out in a dry, covered area.



Information symbol:
Indicates additional information for the operator, to improve the use of the device.



Warning symbol:
Carefully read the sections preceded by this symbol meticulously following the instructions indicated for the safety of the operator and the device.



Danger symbol (corrosive substances):
The operator should always wear protective gloves to avoid the risk of serious injury to the hands caused by corrosive substances.



Danger symbol (battery acid leakage):
Indicates the danger of leaking acid or acid fumes from the batteries while they are being recharged.







Danger symbol (moving carriages):
Indicates that the packed product should be handled with suitable carriages that conform to legal requirements.

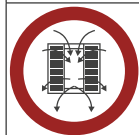

Anchor point symbol:
Indicates the locations of the anchor points to be used to safely tow or secure the machine.



Mandatory room ventilation symbol:
Informs the operator that the room must be ventilated while the batteries are being recharged.

	<p>Symbol indicating the compulsory use of protective gloves: Indicates that the operator should always wear protective gloves, to avoid the risk of serious injury to his hands from sharp objects.</p>
	<p>Symbol indicating the compulsory use of tools: Informs the operator of the need to use tools not included with the machine.</p>
	<p>Symbol indicating a treading ban: Informs the operator that it is forbidden to tread on machine components, as this could lead to serious injury.</p>
	<p>Recycling symbol: Tells the operator to carry out the operations in compliance with environmental regulations in force in the place where the appliance is being used.</p>
	<p>Disposal symbol: Carefully read the sections marked with this symbol for disposing of the appliance.</p>

TECHNICAL DESCRIPTION

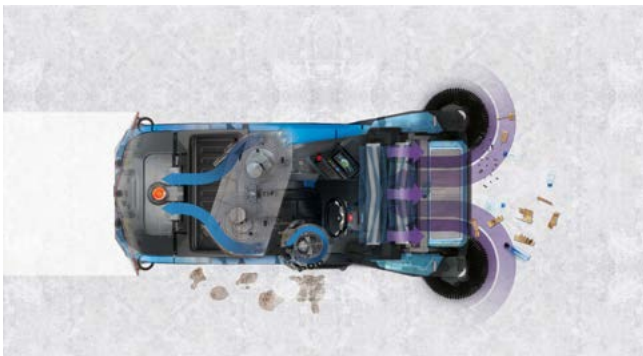

Using the mechanical action of two brushes combined with a chemical solution delivered to the brushes via a pump-controlled water system, the machine is capable of cleaning a wide range of floors and types of dirt. When the machine moves forward, the squeegee collects the dirty solution from the floor, and the vacuum system transfers the dirty solution into the recovery tank. Simultaneously - using the mechanical action of two central front brushes for collecting the swept debris, two side brushes for perimeter and corner cleaning, a suction system equipped with a filter to prevent dust from rising and a debris hopper that can be moved automatically using electric pistons - the machine can be used to clean both indoor and outdoor surfaces, on tiled, concrete or asphalt floors. The machine must operate on dry surfaces,

and if necessary can also work on wet surfaces, provided the vacuum function is not active.

The machine must be used only for this purpose.

INTENDED USE - PLANNED USE (TYPE OF SCRUBBING-DRYING WORK)

This machine was designed and built for the cleaning (scrubbing and drying) of smooth, compact flooring in the commercial, residential and industrial sectors by a qualified operator in proven safety conditions. This machine is not suitable for cleaning carpets or rugs. This machine is only suitable for use in closed (or at least covered) spaces.

 **ATTENTION:** the machine is not suitable for use in the rain, or under water jets.

 **ATTENTION:** IT IS FORBIDDEN to use the machine for picking up dangerous dusts or inflammable liquids in places with an explosive atmosphere. In addition, it is not suitable as a means of transport for people or objects.

INTENDED USE - PLANNED USE (TYPE OF SWEEPING WORK)

This machine is designed and built to clean both indoor and outdoor flooring surfaces in tile, cement and asphalt. They are intended exclusively for professional use by a qualified operator in industrial, commercial and public contexts, in guaranteed safe conditions.

ATTENTION: the sweeping machine is not designed to clean carpets or rugs. It is not suitable for use in closed places and should be used in open but covered areas (it must not be used in the rain or underneath jets of water).

IT IS FORBIDDEN: to use the sweeping machine in places with an explosive atmosphere or to collect hazardous dust or inflammable liquids. In addition, it must not be used for transporting people or objects.

SERIAL NUMBER PLATE

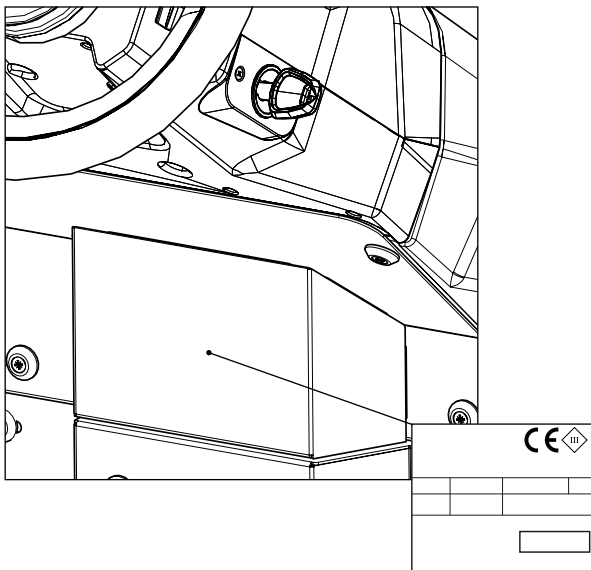

The serial number plate is located near the driver's seat, at the rear of the steering column, and indicates the machine's general characteristics, including its serial number. The serial number is a very important piece of information and should always be provided together with any request for assistance or when purchasing spare parts. The serial number plate contains the following information:

1. The weight of the batteries that power the machine (expressed in kg).
2. The IP protection rating of the machine.
3. The value in Kg of the GVW (Gross Vehicle Weight), see ["TECHNICAL DATA" on page 15](#).
4. The machine ID code.
5. The machine serial number.
6. The machine ID name.
7. The value expressed in W of the nominal power used by the machine, see ["TECHNICAL DATA" on page 15](#).
8. The value expressed in % of the maximum gradeability during work, see ["TECHNICAL DATA" on page 15](#).
9. The year of machine manufacture.
10. The value expressed in V of the nominal voltage used by the machine, see ["TECHNICAL DATA" on page 15](#).
11. The commercial name of the machine, and the manufacturer's address.

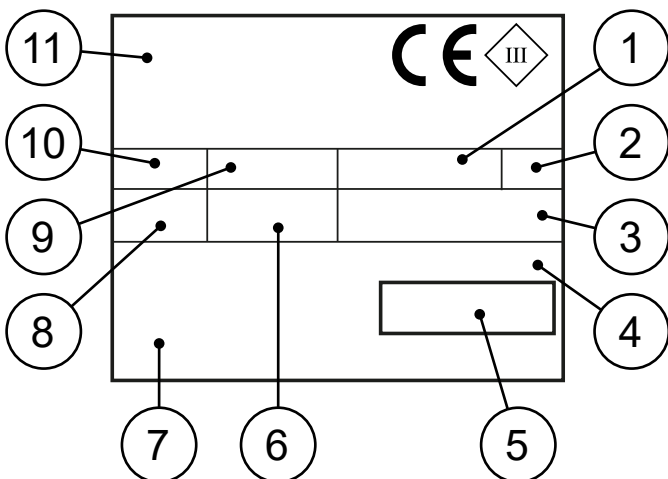

MAIN MACHINE COMPONENTS

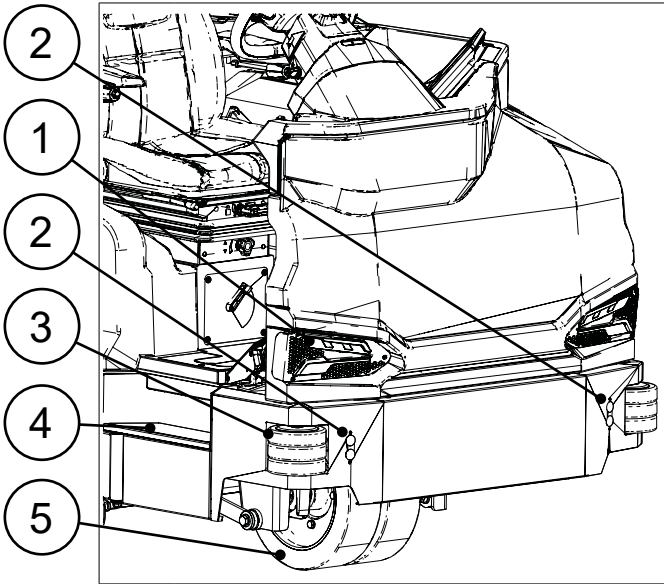

- 1 Working headlights
- 2 Anti-collision system sensor
- 3 Front bumper wheels
- 4 Rung
- 5 Front wheels

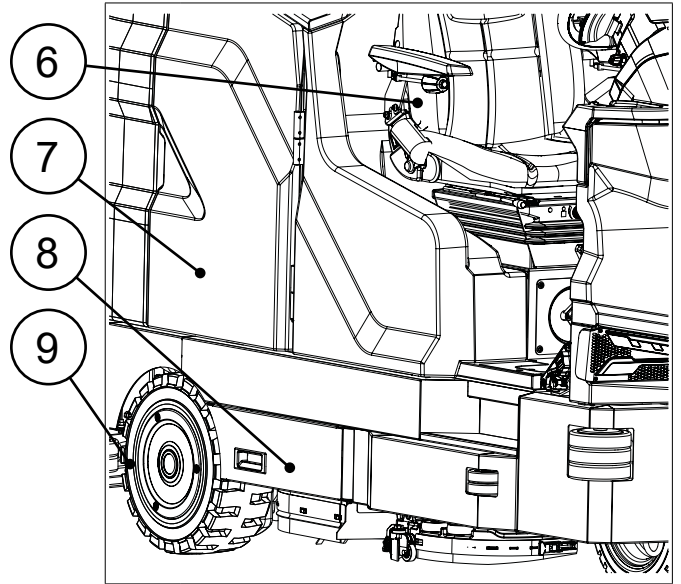

- 6 Driver's seat
- 7 Right rear door
- 8 Brush head inspection door
- 9 Right rear motorwheel

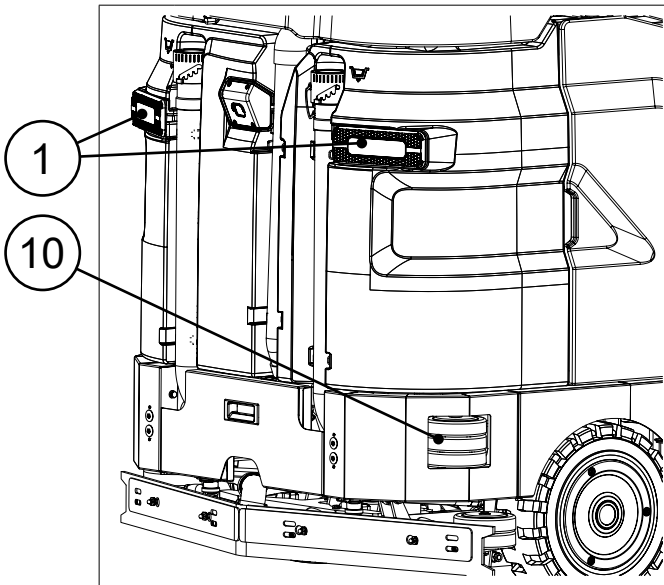

- 1 Working headlights
- 10 Rear bumper wheels

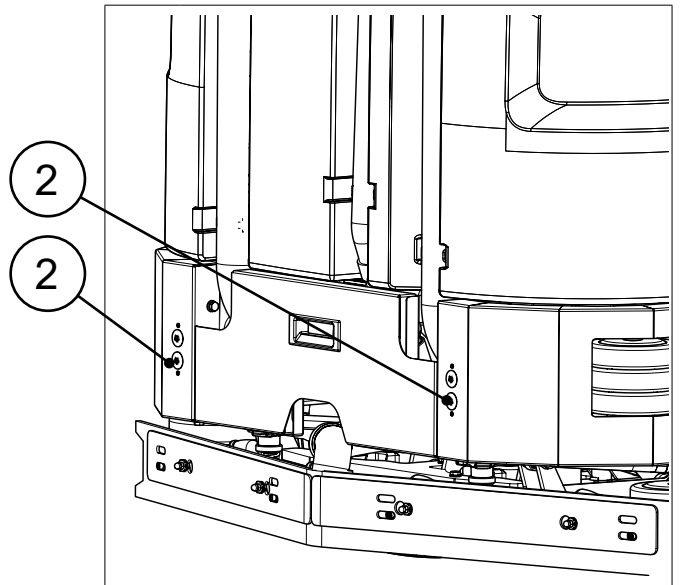

- 2 Anti-collision system sensor

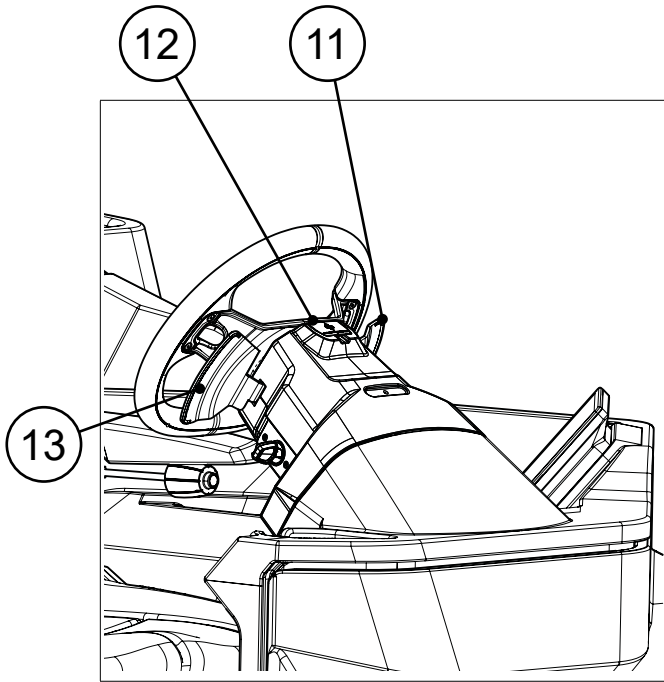

- 11 POWER MODE working program activation lever.
- 12 Automatic technical assistance request button (FFM system)
- 13 Reverse gear function control lever

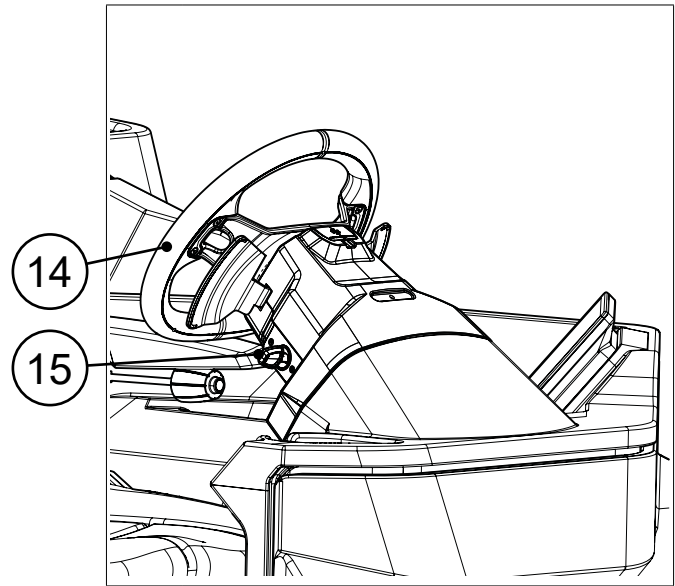

- 14 Steering wheel
- 15 Key-operated main switch

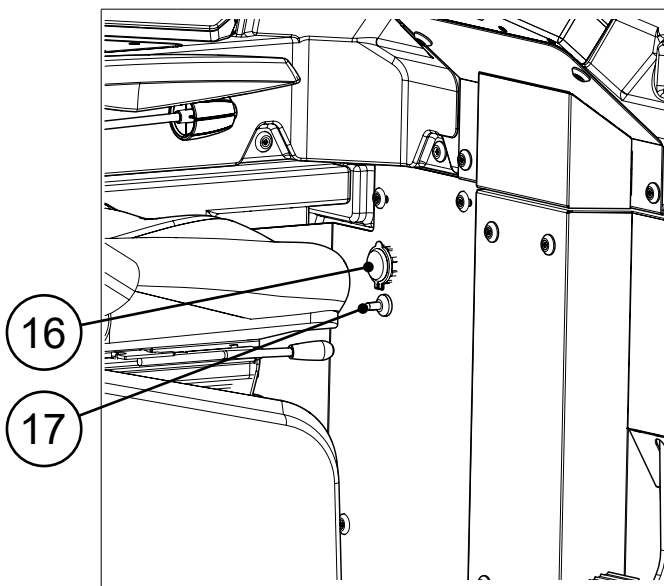

- 16 USB port (optional)
- 17 Service lights control switch

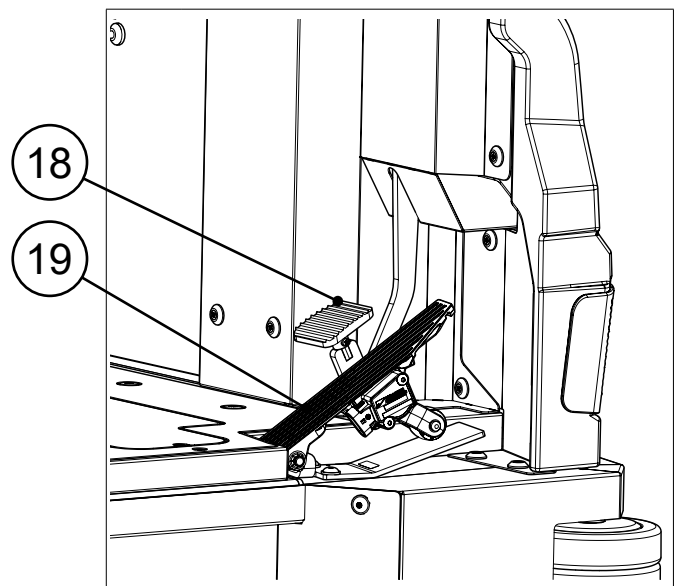

- 18 Service brake pedal
- 19 accelerator pedal

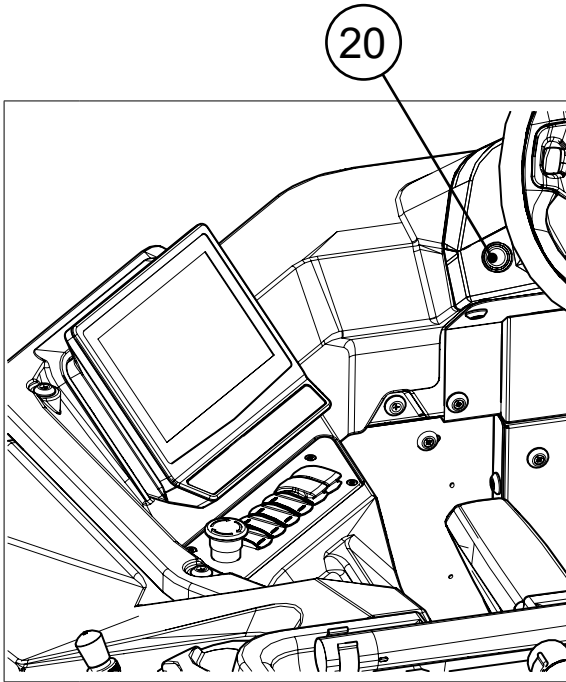

20 Horn button

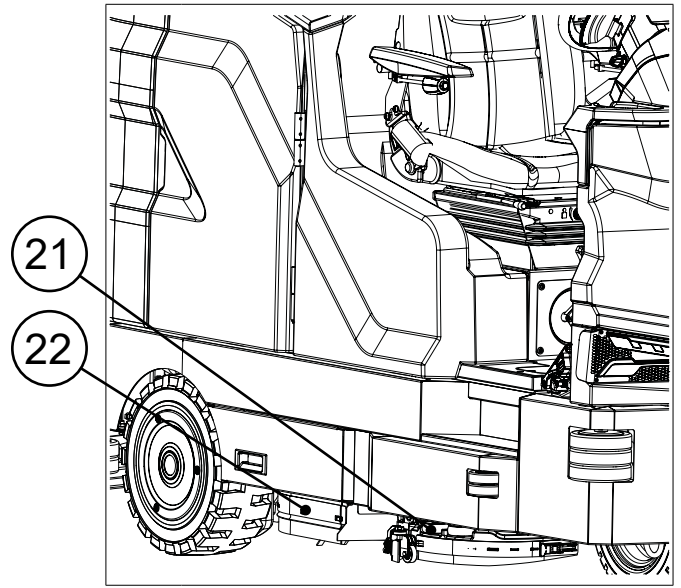

- 21 Side brush head, valid for discoid scrubbing version (optional)
- 22 Central brush head, valid for discoid scrubbing version

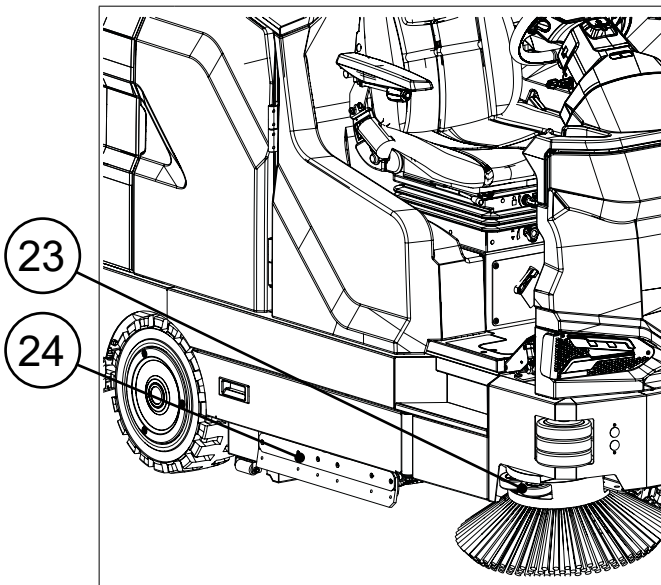

- 23 Side sweeping brush, valid for cylindrical scrubbing versions (optional)
- 24 Central brush head, valid for cylindrical scrubbing versions

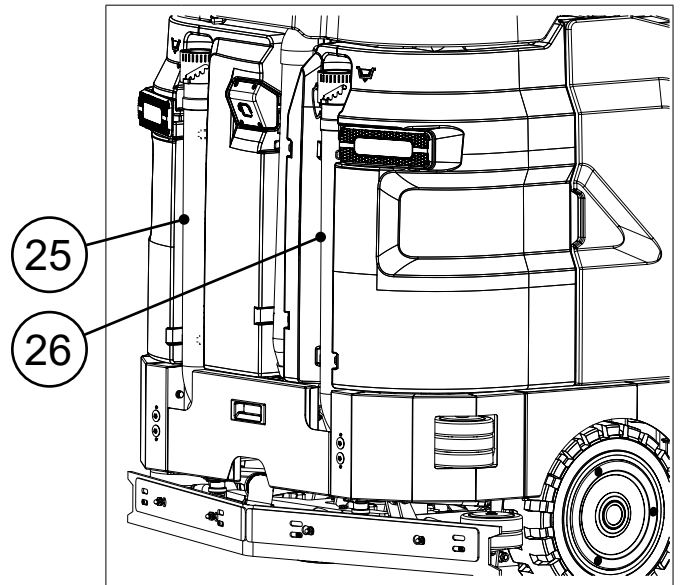

- 25 Solution tank drain hose
- 26 recovery tank drainage tube



- 27 Inspection footboard and recovery tank maintenance
- 28 Squeegee bumper wheels
- 29 Squeegee

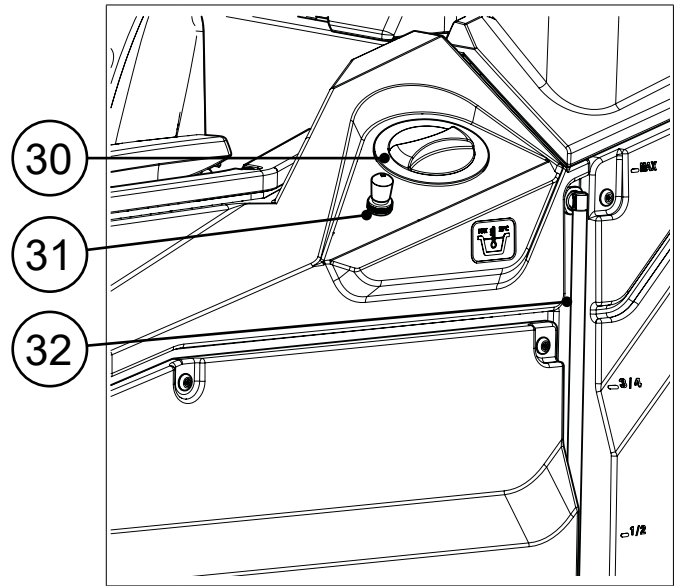

- 30 Solution tank filler cap
- 31 Solution tank quick filling kit hose connector (FFF system)
- 32 Solution tank fill volume level hose

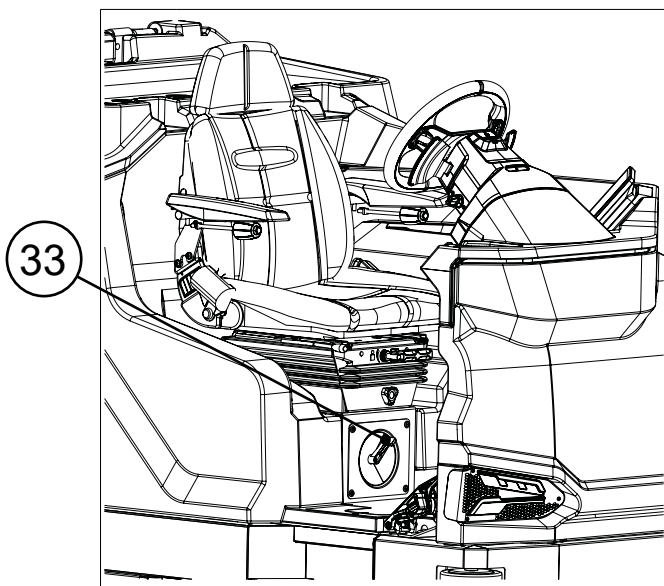

- 13 Detergent solution delivery control lever

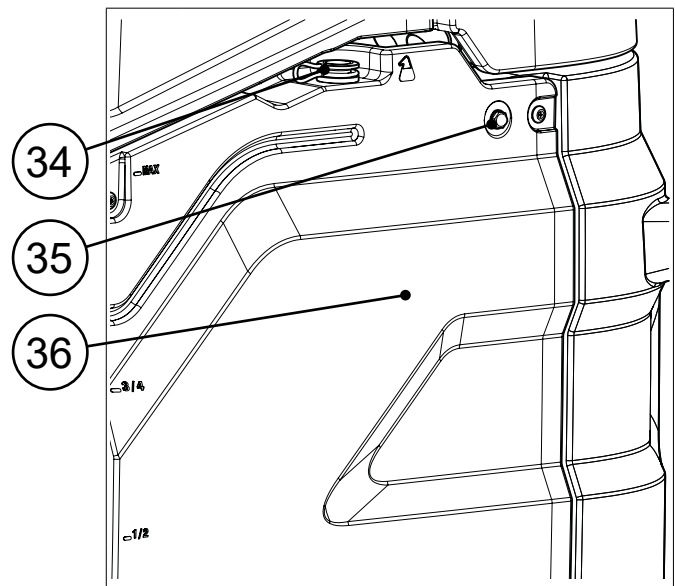

- 34 Chemical detergent filler cap (FSS system)
- 35 Chemical detergent tank MAX level indicator (FSS system)
- 36 Chemical detergent tank (FSS system)

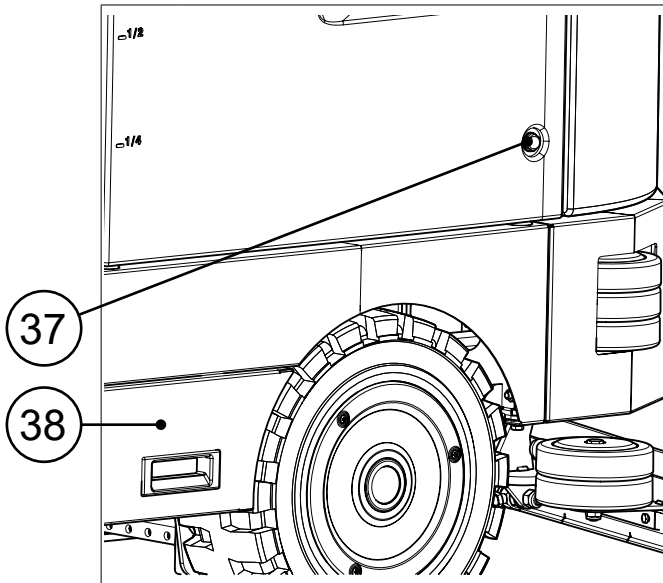

- 37 Chemical detergent tank MIN level indicator (FSS system)
- 38 Brush head and water system filter inspection door

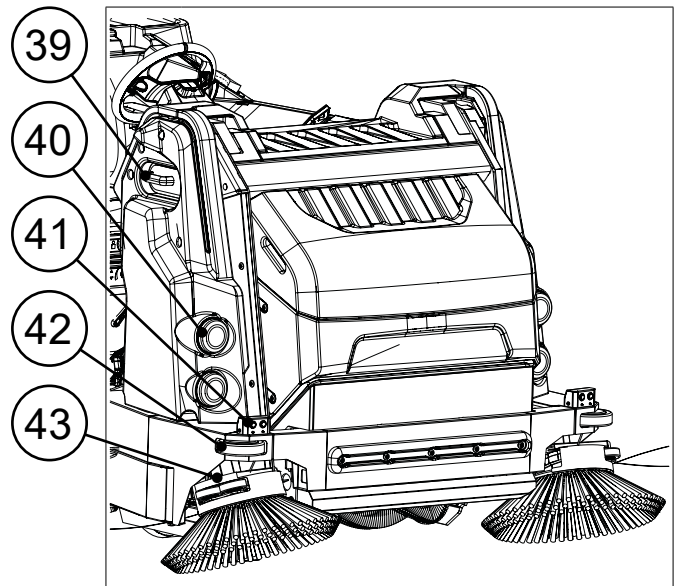

- 39 Debris hopper maintenance safety stop
- 40 Working headlights
- 41 Anti-collision system sensor
- 42 Front bumper wheel
- 43 Side sweeping brush

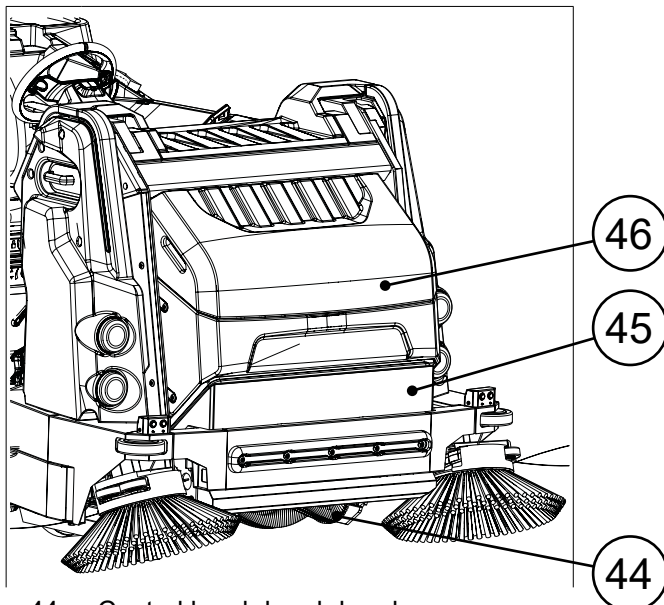

- 44 Central brush brush head
- 45 Debris hopper
- 46 Vacuum filter cover

TECHNICAL DATA

TECHNICAL DATA	UM [SI]	GMG B PLUS	GMG BS PLUS	GMG BC PLUS
Rated voltage [IEC 60335-2-72; IEC 62885-9]	V	36	36	36
Nominal input power [IEC 60335-2-72; IEC 62885-9]	KW	10,7	11,4	13,6
Working gradeability GVW [IEC 60335-2-72; IEC 62885-9]	%	20	20	20
Gross weight GVW [IEC 60335-2-72; IEC 62885-9]	kg	2215	2205	2745
Weight during transport [IEC 60335-2-72; IEC 62885-9]	kg	1795	1820	2250
Machine dimensions during working phase (length; height width)	mm	2310 1555 1250	2310 1555 1250	2965 1555 1525
Operator station sound pressure level (L _{pA}) [IEC 60335-2-72; IEC 62885-9; ISO 11201]	dB (A)	67	67	71,5
Sound power level (L _w) [IEC 60335-2-72; IEC 62885-9; ISO 3744]	dB (A)	88	88	92,2
Uncertainty K _{pA}	dB (A)	±1.5	±1.5	1.5
Hand-arm vibrations [IEC 60335-2-72; IEC 62885-9; ISO 5349-1]	m/s ²	0,5	0,5	0,81
Whole-body vibrations [IEC 60335-2-72; IEC 62885-9; ISO 2631-1]	m/s ²	0,4	0,4	0,45
Vibration measurement uncertainty		±4%	±4%	±4%

i **N.B.:** for all other technical data, contact the FIMAP service centre of reference or the one closest to you, or visit the website www.fimap.com.

TECHNICAL DATA		UM [SIB]	GMG B PLUS	GMG BS PLUS	GMG BC PLUS
Rated voltage [IEC 60335-2-72; IEC 62885-9]		V	36	36	36
Nominal input power [IEC 60335-2-72; IEC 62885-9]		KW	10,7	11,4	13,6
Working gradeability GVW [IEC 60335-2-72; IEC 62885-9]		%	20	20	20
Gross weight GVW [IEC 60335-2-72; IEC 62885-9]		lbs	4883,24	4861,19	6.051,69
Weight during transport [IEC 60335-2-72; IEC 62885-9]		lbs	3957,30	4012,41	4.960,40
Machine dimensions during working phase (length; height width)		in	90,94 61,22 49,21	90,94 61,22 49,21	116,73 61,22 60,04
Operator station sound pressure level (Lp _A) [IEC 60335-2-72; IEC 62885-9; ISO 11201]		dB (A)	67	67	71,5
Sound power level (Lw _A) [IEC 60335-2-72; IEC 62885-9; ISO 3744]		dB (A)	88	88	92,2
Uncertainty Kp _A		dB (A)	±1.5	±1.5	1.5
Hand-arm vibrations [IEC 60335-2-72; IEC 62885-9; ISO 5349-1]		m/s ²	0,5	0,5	0,81
Whole-body vibrations [IEC 60335-2-72; IEC 62885-9; ISO 2631-1]		m/s ²	0.4	0.4	0,45
Vibration measurement uncertainty			±4%	±4%	±4%

SYMBOLS USED ON THE MACHINE

P

Extra pressure activation/deactivation lever position symbol:

Used on the extra brush head pressure activation-deactivation lever, see [“POWER MODE WORKING PROGRAM” on page 69](#)

R

Reverse gear activation/deactivation lever position symbol:

Used on the reverse activation-deactivation lever, see [“REVERSE GEAR” on page 89](#)

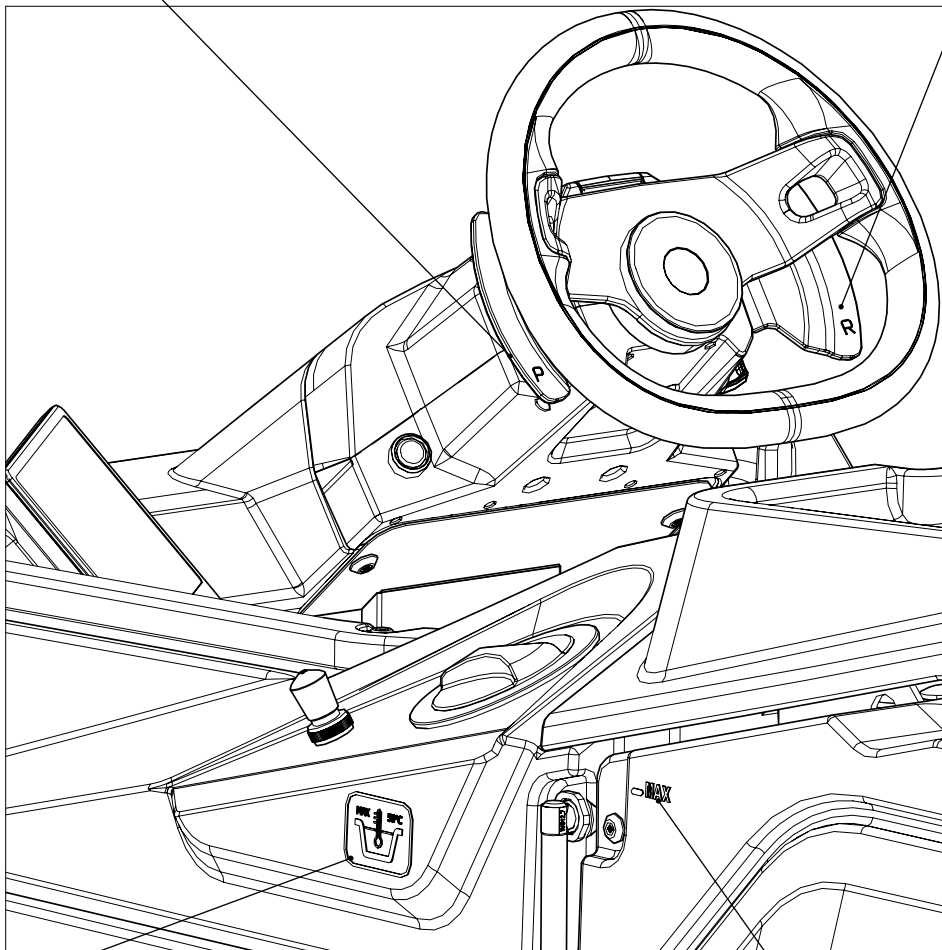

Symbol for maximum temperature for filling the solution tank:

Applied to the left-hand side of the machine's solution tank to indicate the maximum temperature of the water that can be used to safely fill the solution tank, see [“DETERGENT SOLUTION” on page 46](#)



Solution tank filling symbol:

Located on the left side of the machine's solution tank to indicate the amount of water or detergent solution in the tank. On the side there are four symbols representing $\frac{1}{4}$ of the solution tank's total capacity. The image to the side shows that the tank is full.

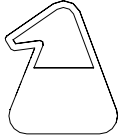

Chemical detergent symbol:

Applied to the left-hand side of the machine's solution tank to indicate the chemical detergent tank. Symbol only valid for versions with automatic management of the chemical product, see [“DETERGENT SOLUTION” on page 46](#)

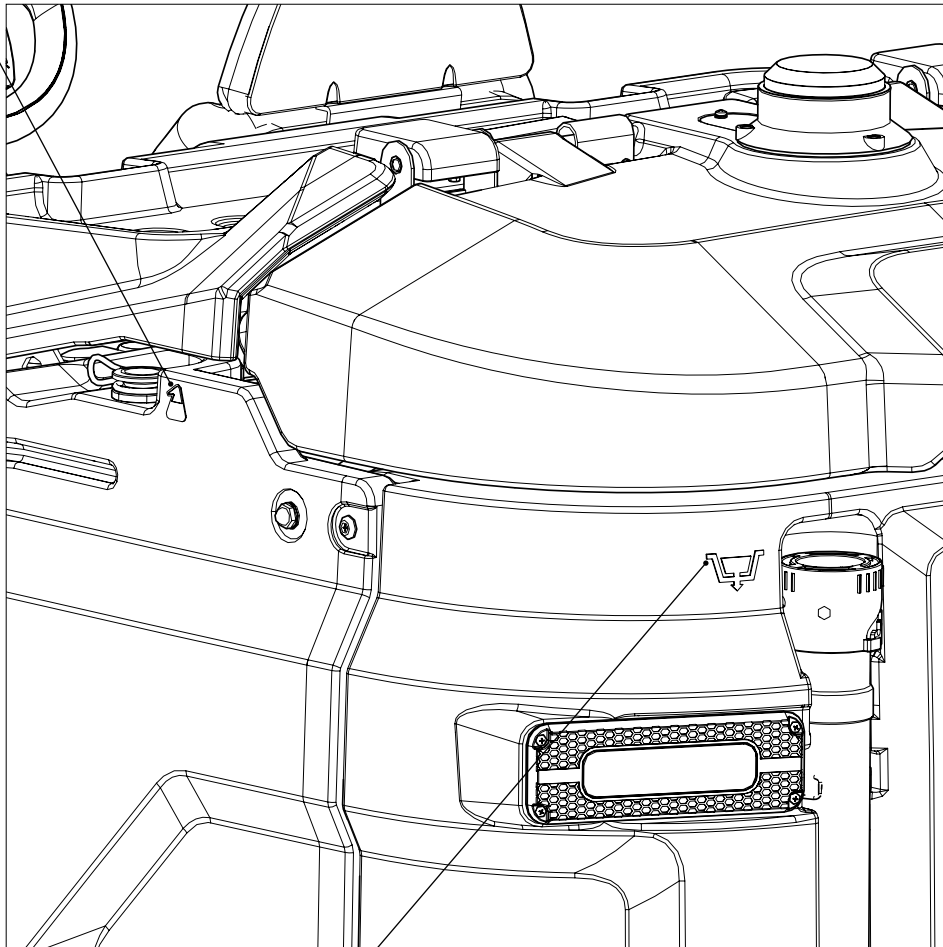





Recovery tank drainage hose symbol:

Used on the rear right-hand side of the machine, to identify the recovery tank emptying tube, see [“DRAINING THE RECOVERY TANK” on page 121](#)

Solution tank drain pipe symbol:

Used on the rear right-hand side of the machine, to identify the solution tank emptying tube, see [“EMPTYING THE SOLUTION TANK” on page 123](#)

	<p>Service function symbol: Used on the control panel to indicate the switch that enables the maintenance position function, see “SERVICE FUNCTION” on page 86</p>
	<p>Brush uncoupling function symbol: Used on the control panel to indicate the switch that enables the "BRUSH UNCOUPLING" function, see “BRUSH UNCOUPLING FUNCTION (DISCOID SCRUBBING VERSION)” on page 87</p>
	<p>Recovery tank spray cleaning gun activation symbol: Used on the control panel to indicate the switch that controls the internal cleaning system of the recovery tank through the spray gun, see “RECOVERY TANK SPRAY CLEANING GUN” on page 100</p>
	<p>Vacuum wand activation symbol: Used on the control panel to indicate the switch that controls the liquid vacuum wand, see “LIQUID VACUUM WAND” on page 102</p>

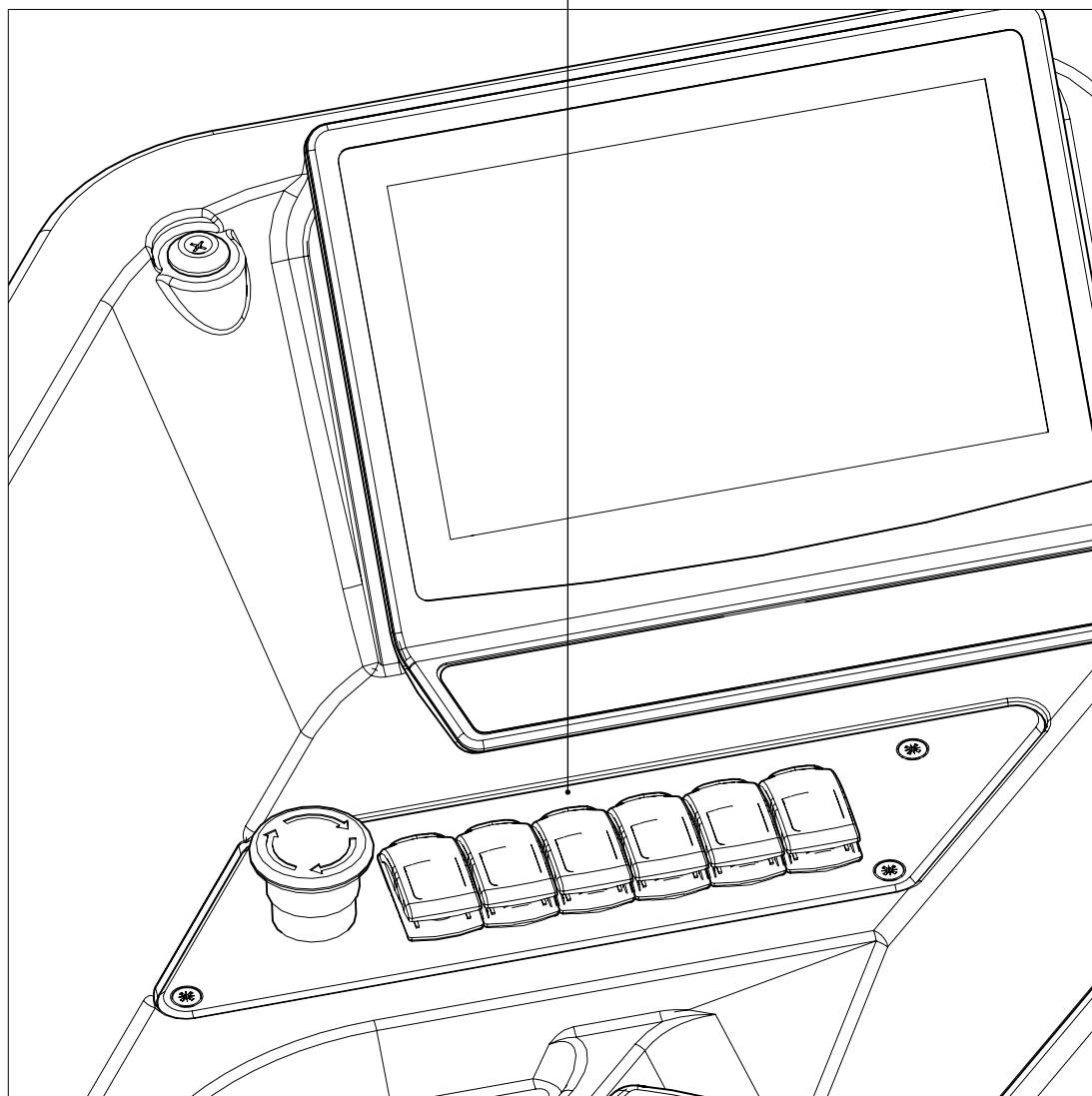

LABELS USED ON THE MACHINE

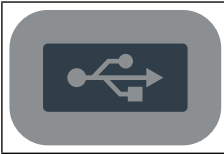

USB port label:

Used on the lower part of the steering column to indicate the location of the two USB ports, see [“USB PORT” on page 99](#)



Machine main switch label:

Applied to the lower part of the steering column to indicate the location of the machine's main switch.



"Operator present" label (combined version):

Used on the lower part of the steering column to indicate the position of the operator presence button, used during the rotation phase in the work position of the debris hopper in the combined version.

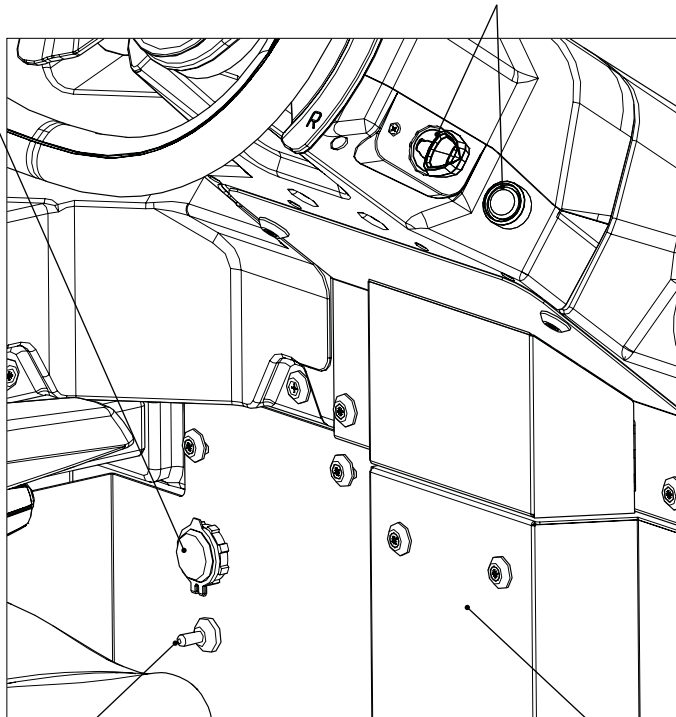

Blinking lights control label:

Applied to the lower part of the steering column to indicate the location of the service lights switch, see [“SERVICE LIGHTS” on page 87](#)



Prohibition to vacuum hazardous elements label:

Applied to the lower part of the steering column to indicate that it is strictly prohibited to vacuum incandescent particles or flammable and/or explosive powders and/or liquids with the machine, and to operate the machine in their vicinity.



Tap control lever label:

Applied to the front of the solution tank to indicate the tap control lever.

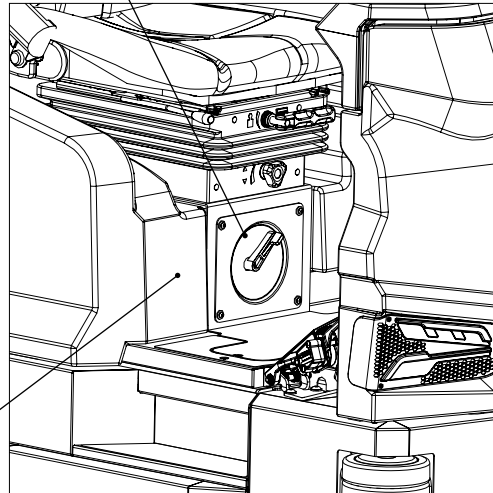

Daily maintenance label:

Used on the front of the solution tank, near the tap control lever, to indicate the need to close the tap at the end of work and to carry out daily maintenance [“DAILY MAINTENANCE” on page 110](#)



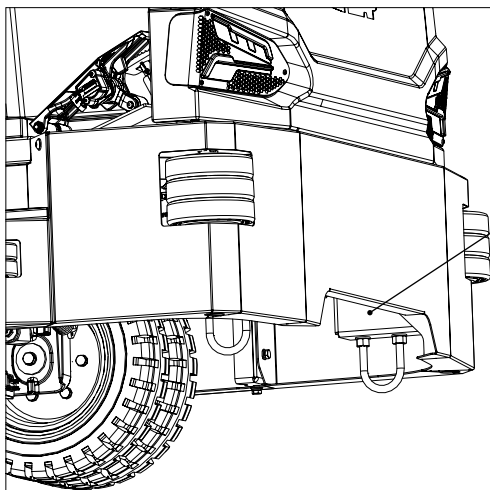

Anchor hook label:

Applied to the front of the machine to identify the two hooks used to securely anchor the machine.



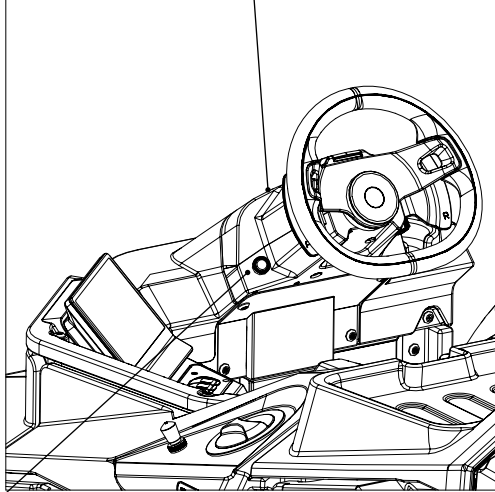

	<p>Label indicating the need to read the Use and Maintenance Manual: Applied to the front of the steering column to indicate the need for the user to read the user and maintenance manual before operating the machine.</p>
---	---

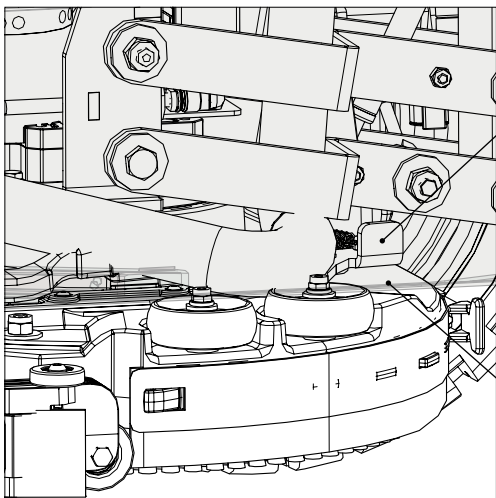

	<p>Horn button label: Applied to the left side of the steering column to identify the machine's horn button.</p>
--	---

	<p>Side scrubbing brush uncoupling lever label (optional): Applied to the front of the side brush head to indicate the side scrubbing brush uncoupling lever.</p>
---	--



 <p><small>Do not go next to the brush head while the brush is moving.</small></p>	<p>Label indicating that touching the brush when moving is prohibited: Applied to the side brush head to indicate the prohibition to place your hands in the vicinity of the brush head while the brush is in motion.</p>
---	--

36V

Rated voltage label:
Applied to the electrical system connector support to indicate the machine's rated voltage value.

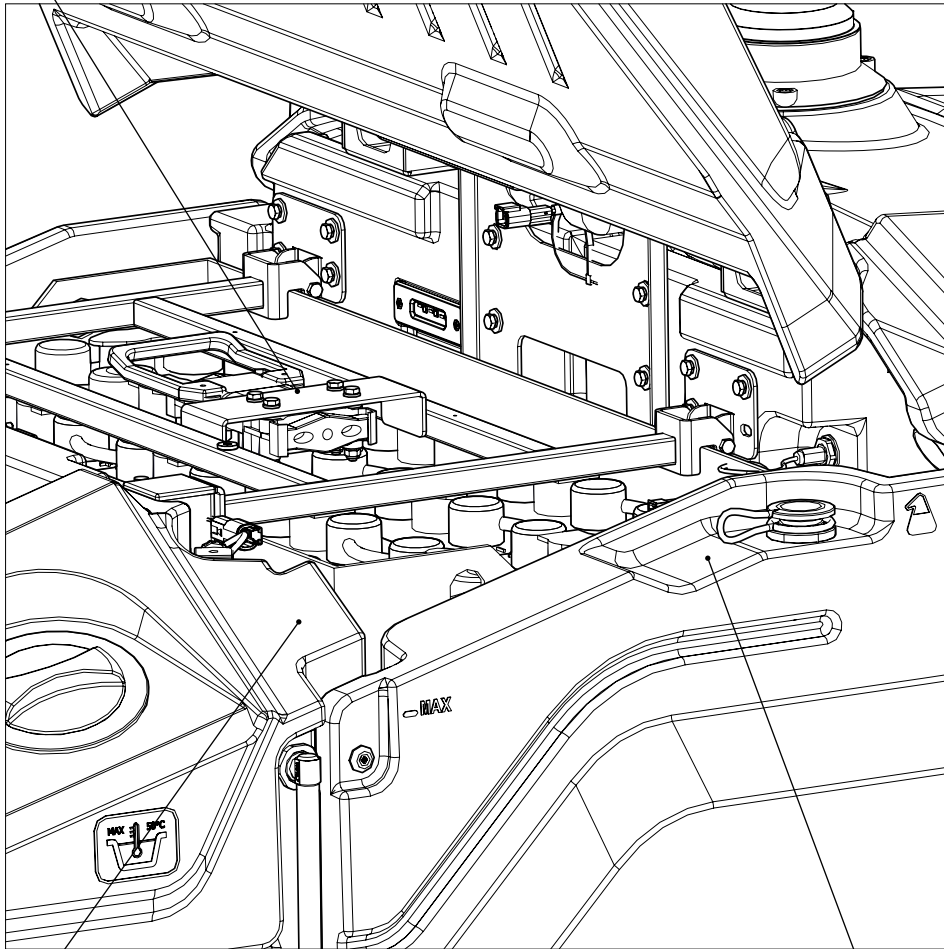



Label warning about the risk of crushed hands:
Applied to the solution tank to indicate the areas where hand crushing hazards are present.



Chemical pH range label (FSS versions):
Applied near the detergent tank's cap to indicate the chemical product pH range within which the FSS system operates without causing damage to the machine.



Battery box warning label:

Applied to the inside of the battery box lid to warn that the cells could release highly flammable hydrogen gas during the recharging phase. See [“RECHARGING THE BATTERY BOX” on page 42](#)



Battery box charging instructions label:

Applied to the inside of the battery box lid to indicate the procedures to be followed in order to properly charge the battery box. See [“RECHARGING THE BATTERY BOX” on page 42](#)

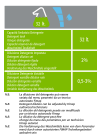
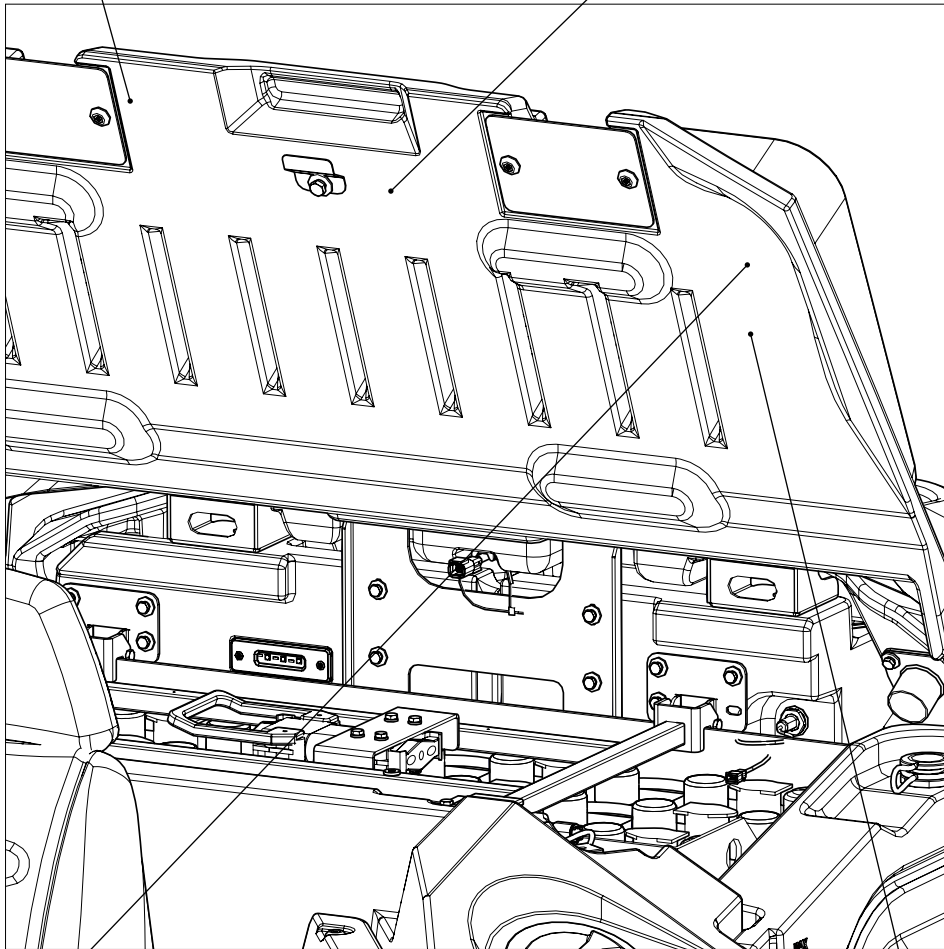

FSS system technical data label (FSS versions):

Applied to the inside of the battery box lid to indicate the technical characteristics of the automatic chemical product dosing system (FSS system).



Warning label for the automatic chemical product dosing system (FSS versions):

Applied to the inside of the battery box lid to indicate the precautions to be taken when using the automatic chemical product dosing system (FSS system).



Treading ban label:

Applied to the lateral inspection doors to identify the surfaces that must not be trodden upon (risk of personal injury or damage to the machine)



Do not go next to the brush head while the brush is moving.

Label indicating that touching the brush when moving is prohibited:

Applied to the left and right sides of the brush head to indicate the prohibition to place your hands in the vicinity of the brush head while the brush is in motion.

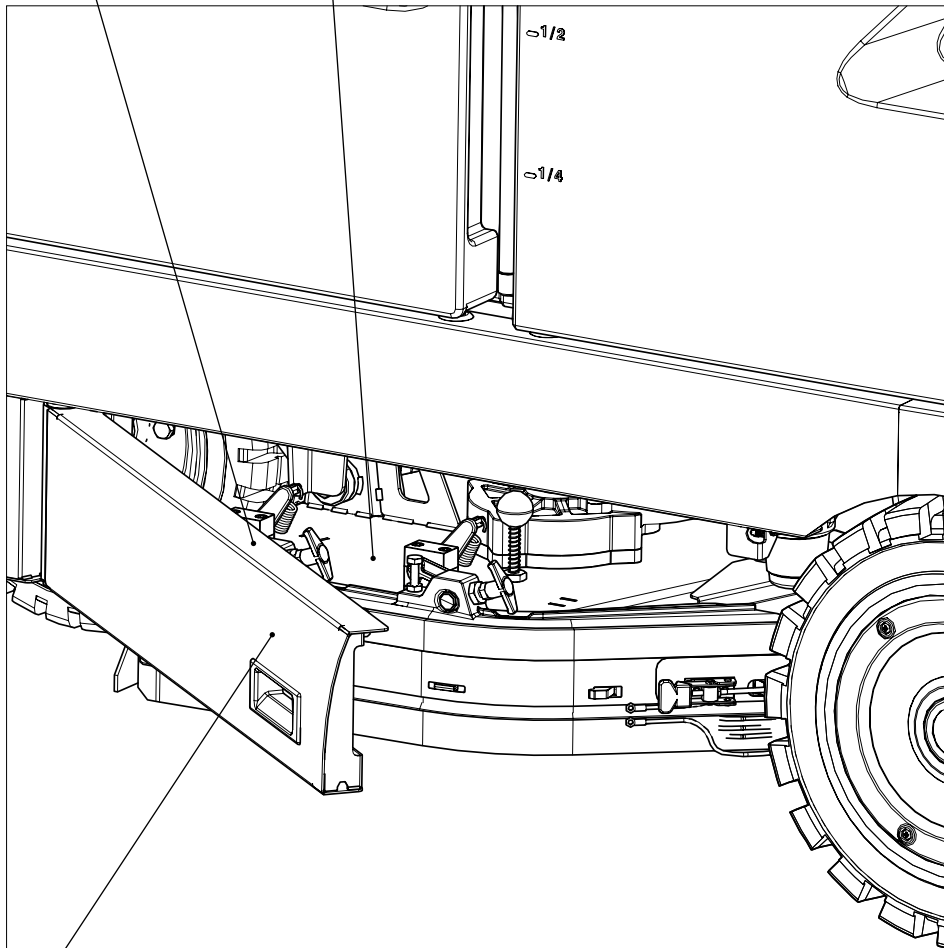

Water system filter maintenance warning label:

Applied to the left inspection panel to remind the operator of the need to perform maintenance upon the water system filter each time the machine is utilised.



Inspection footboard-recovery tank maintenance label:
 Applied to the rear of the machine to indicate the footboard used to inspect and service the recovery tank.

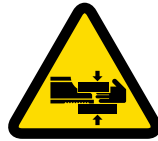
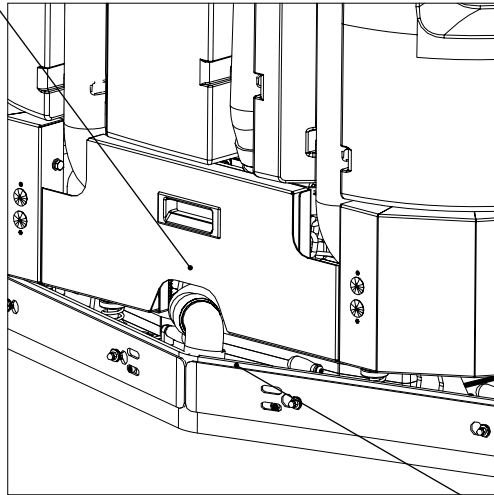

Lower limb and hand crushing hazard label:
 Applied at the rear of the machine to warn the user that there is a risk of crushing the lower limbs and hands when the squeegee is in motion.

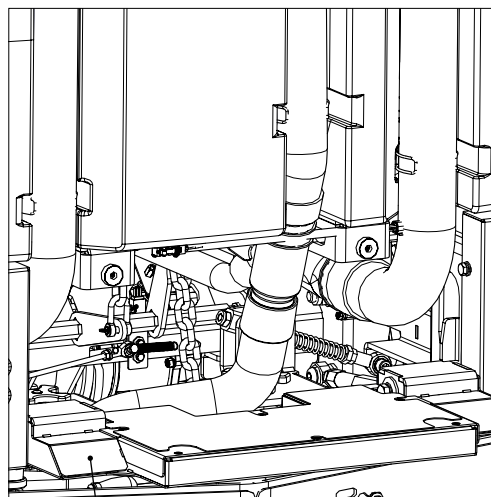

Label forbidding the use of the machine as a means of transport:
 Applied to the rear of the machine to indicate that the recovery tank inspection footboard should not be used to transport people.

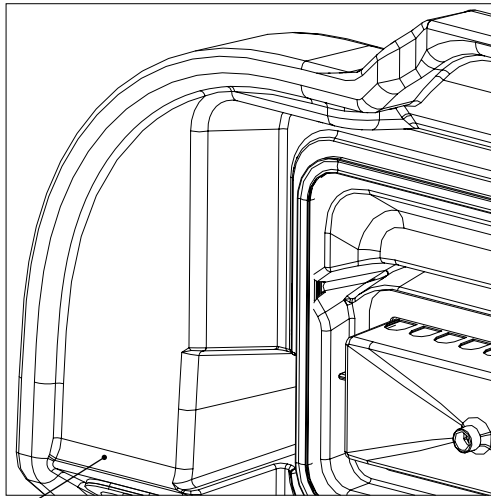

Suction motor filter maintenance label:

Applied to the inside of the recovery tank's lid to remind the user to perform maintenance on the suction motor filter after every machine use. See ["DAILY MAINTENANCE" on page 110](#)



Recovery tank drainage tube label:

Applied to the rear of the machine to indicate the recovery tank's drainage tube. See ["DRAINING THE RECOVERY TANK" on page 121](#)

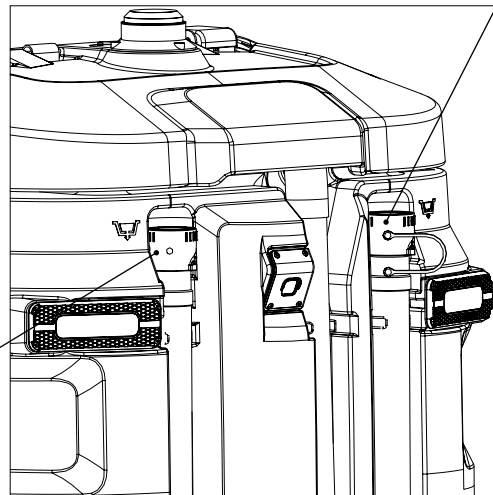

Solution tank drainage tube label:

Applied to the rear of the machine to indicate the solution tank's drainage tube. See ["EMPTYING THE SOLUTION TANK" on page 123](#)

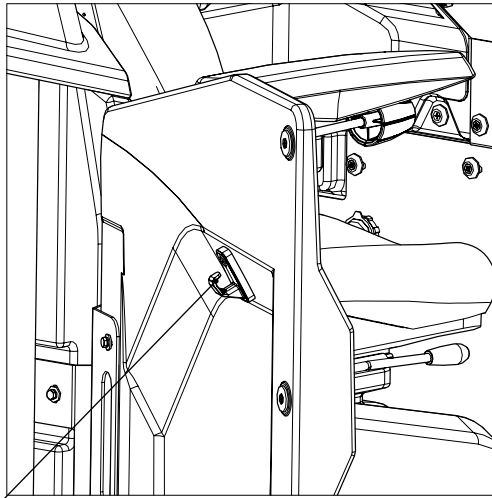

recovery tank spray cleaning gun label (optional):

Applied inside the right rear carter to indicate the support hook for the recovery tank spray cleaning gun. See [“RECOVERY TANK SPRAY CLEANING GUN” on page 100](#)



Safety label on debris hopper lifting arms (combined version):

Used on the front right-hand side, adjacent to the debris hopper rotation fulcrum, to indicate the safety pin that must be used during maintenance.

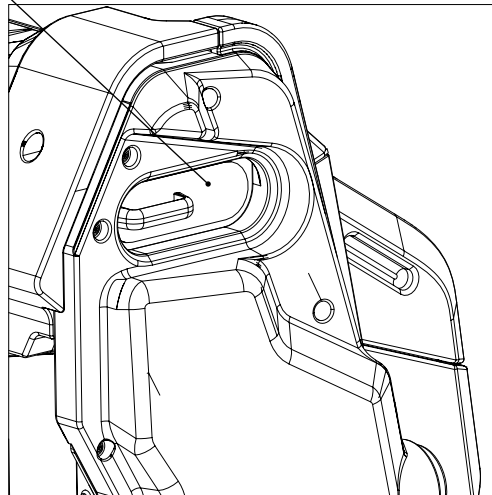

CONTROL STATION

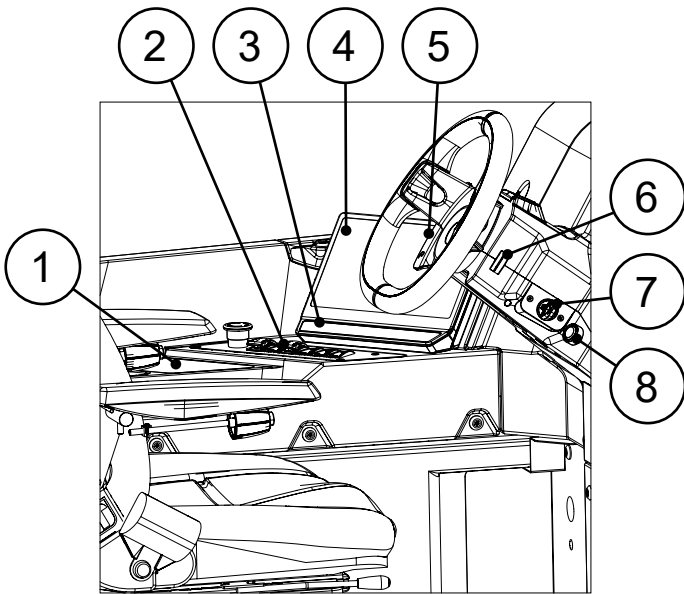

The machine has an easy and user-friendly control station, comprised of mainly the following:

1. Membrane panel for moving the debris hopper present on the combined machine version, see [“MEMBRANE PUSH-BUTTON PANEL FOR MOVING THE DEBRIS HOPPER \(COMBINED VERSION\)”](#) ON PAGE 29.
2. Push-button control panel, see [“CONTROL PUSH-BUTTON PANEL”](#) ON PAGE 30.
3. Membrane push-button panel for controlling the sweeping head, see [“MEMBRANE PUSH-BUTTON PANEL FOR ACTIVATING WORKING PROGRAMS”](#) ON PAGE 30.
4. Control display, see [“CONTROL DISPLAY”](#) ON PAGE 31.
5. Power mode work program control pad lever, see [“POWER MODE WORKING PROGRAM”](#) on page 69.

6. Reverse control pad lever, see [“REVERSE GEAR”](#) on page 89.
7. Machine main switch.
8. Operator presence button for moving the debris hopper.

MEMBRANE PUSH-BUTTON PANEL FOR MOVING THE DEBRIS HOPPER (COMBINED VERSION)

The membrane push-button panel on the left-hand side of the control station can be used to control the movement of the debris hopper and the filter-shaker in the suction system.

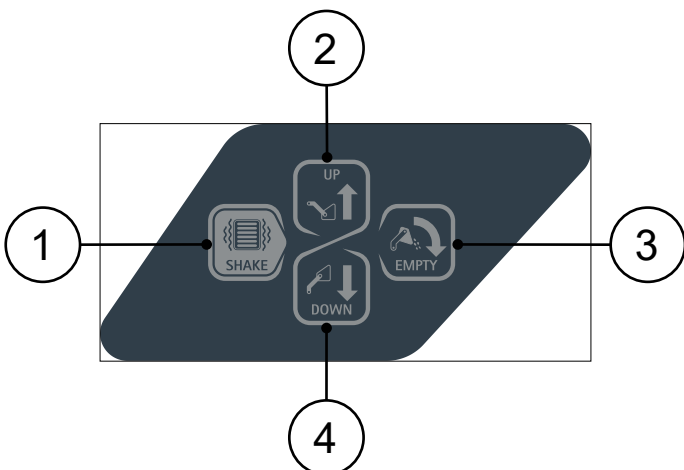

The membrane push-button panel is divided as follows:

1. Filter-shaker activation button.
2. Debris hopper (upwards) movement activation button.
3. Debris hopper rotation activation button.
4. Debris hopper (downwards) movement activation button.

CONTROL PUSH-BUTTON PANEL

With the control panel, located on the left of the control station, it is possible to activate the optional machine functions, thereby increasing productivity and reducing costs.

The control panel is divided as follows:

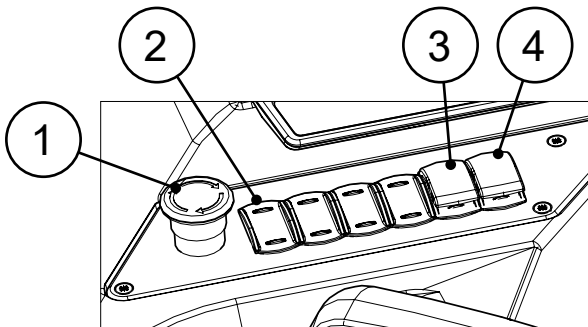

1. Emergency switch, see [“EMERGENCY BUTTON” on page 88.](#)
2. Service function control button, see [“SERVICE FUNCTION” on page 86.](#) Or brush release function control switch, see [“BRUSH UNCOUPLING FUNCTION \(DISCOID SCRUBBING VERSION\)” on page 87.](#)
3. Recovery tank cleaning spray gun control switch, see [“RECOVERY TANK SPRAY CLEANING GUN” on page 100.](#)
4. Liquid vacuum wand system control switch, see [“LIQUID VACUUM WAND” on page 102.](#)

MEMBRANE PUSH-BUTTON PANEL FOR ACTIVATING WORKING PROGRAMS

With the membrane push-button panel in the machine control panel, it is possible to quickly call up one of the five working programs or access the screen to modify one of the four working parameters, which increases productivity and reduces costs.

All the tasks are managed using a simple user interface where only a dedicated button needs to be pressed.

The membrane push-button panel is divided as follows:



1. ECO MODE working program activation button, see [“ECO MODE WORKING PROGRAM” on page 63.](#)
2. COMFORT MODE working program activation button, see [“COMFORT MODE WORKING PROGRAM” on page 64.](#)
3. DYNAMIC MODE working program activation button, see [“DYNAMIC MODE WORKING PROGRAM” on page 65.](#)
4. HEAVY MODE working program activation button, see [“HEAVY MODE WORKING PROGRAM” on page 66.](#)
5. ZONE MODE working program activation button, see [“ZONE MODE WORKING PROGRAM” on page 67.](#)
6. Forward speed adjustment button, see [“REGULATING THE FORWARD SPEED” on page 83.](#)
7. Pressure exerted on the brush head adjustment button, see [“ADJUSTING THE PRESSURE EXERTED ON THE BRUSH HEAD” on page 82.](#)
8. Detergent solution flow adjustment button, see [“ADJUSTMENT OF THE DETERGENT SOLUTION FLOW” on page 84.](#)
9. Vacuum system performance adjustment button, see [“VACUUM SYSTEM PERFORMANCE ADJUSTMENT \(SCRUBBING VERSION\)” on page 85.](#)

CONTROL DISPLAY

With the control display located on the machine control panel, it is possible to access essential information to make more accurate selections and increase the professionalism of interventions, which increases productivity and reduces costs..



All the tasks are managed using a simple user interface; intuitive and dynamic, simply touch the screen to have the same intuitive sensation as a smartphone.

The “MAIN” screen is divided as follows:



1. Video tutorial screen activation button, see [“TUTORIAL” on page 97.](#)
2. Working mode selector, see [“DS SELECTOR \(DRIVE SELECT\)” on page 70.](#)
3. Machine direction indicator, the red-colored arrow enables you to view the position of the front wheel with respect to its vertical axis of rotation.
4. Active working program icon, see [“WORKING PROGRAMS” on page 62.](#)
5. Text indicator.
6. Vacuum system debris hopper performance level indicator (valid for sweeping working mode), see [“VACUUM SYSTEM DEBRIS HOPPER PERFORMANCE ADJUSTMENT \(COMBINED VERSION\)” on page 86.](#)
7. Menu screen activation button, see [“IMPOSTAZIONI GENERALI MACCHINA” on page 9.](#)
8. Detergent solution flow adjustment button, see [“ADJUSTMENT OF THE DETERGENT SOLUTION FLOW” on page 84.](#)
9. Rear view camera screen activation button, see [“REAR VIEW CAMERA” on page 94.](#)
10. Vacuum system performance adjustment button, see [“VACUUM SYSTEM PERFORMANCE ADJUSTMENT \(SCRUBBING VERSION\)” on page 85.](#)
11. Water reserve in the solution tank symbol, if displayed fill the detergent solution tank, see [“DETERGENT SOLUTION” on page 46 .](#)
12. Recovery tank full symbol, if displayed empty the recovery tank, see [“DRAINING THE RECOVERY TANK” on](#)

[page 121](#) .

13. Generic alarm symbol, if displayed stop the machine and see [“ALARM SCREEN” on page 93](#).
14. Solution tank level indicator, see [“SOLUTION TANK FILL LEVEL INDICATOR” on page 78](#).
15. Working headlights on activation/ deactivation button, see [“WORKING HEADLIGHTS” on page 92](#).
16. Battery box charge level indicator, see [“BATTERY BOX CHARGE LEVEL INDICATOR” on page 77](#).
17. Button for activation/deactivation of side brushes present in the combined machine version, see [“SIDE BRUSH \(COMBINED VERSION\)” on page 98](#).
18. Hour meter, see [“HOUR METER” on page 76](#).
19. Scrubbing side brush in working position symbol, see [“SIDE BRUSH \(DISCOID SCRUBBING VERSIONS\)” on page 104](#). Or sweeping side brushes in working position symbol, see [“SIDE BRUSH \(CYLINDRICAL SCRUBBING VERSION\)” on page 105](#).
20. For versions with the FSS system, the symbol  identifies that the automatic detergent dosing system is active, see [“FSS - AUTOMATIC DETERGENT DOSING SYSTEM” on page 107](#). Or for versions with the FLR system, the symbol  identifies that the automatic detergent dosing system is active, see [“FLR - CONTINUOUS RECYCLING SYSTEM” on page 106](#).
21. FFM system active symbol, see [“FFM - TAG INSERTION” on page 103](#).
22. Pressure exerted on the brush head adjustment button, see [“ADJUSTING THE PRESSURE EXERTED ON THE BRUSH HEAD” on page 82](#).
23. Forward speed adjustment button, see [“REGULATING THE FORWARD SPEED” on page 83](#).

TOUCH SCREEN

The control display features a capacitive touch screen, which is essentially a special touch screen that takes advantage of the dielectric capacitance variation typical of the capacitors on the glass of the screen itself. Capacitive touch screens offer greater image brightness and sharpness due to the surface layer of glass, which also makes them more durable than resistive touch screens. With this touch technology, the user experience is more pleasant, as there is no need to press on the display.

Below are the main steps required for using a capacitive touch screen display

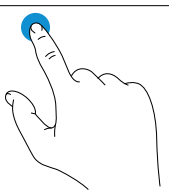
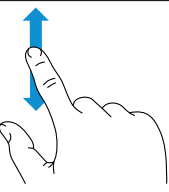
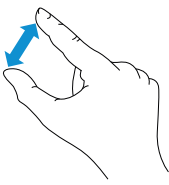
	ACTION	MOVEMENTS
	Select an element	Touch the screen
	Scroll	Place a finger on the screen and scroll horizontally or vertically
	Zoom forwards or backwards	Place two fingers on the screen and move them closer or further apart.

PREPARATION OF MACHINE

HANDLING THE PACKAGED MACHINE

The overall dimensions of the entire package are:

DIMENSIONS	GMG B	GMG BS	GMG BC
Length (cm)	240	240	310
Width (cm)	150	150	165
Height (cm)	190	190	190
Weight (kg/l)	1110	1170	1690

 **N.B.:** it is recommended that all the packaging components be kept for any future machine transportation.

 **DANGER:** Move the packaged product with handling trolleys that comply with legal requirements regarding size and mass of the packaging.

HOW TO UNPACK THE MACHINE

The machine is shipped in specific packaging. To remove it, proceed as follows:

1. Place the lower part of the outer packaging in contact with the floor.

 **N.B.:** use the pictograms printed on the box as a reference.

2. Remove the outer package.

 **WARNING:** the machine is contained in specific packaging materials, whose elements (plastic bags, staples, etc.) can pose potential hazards, and must not be left within reach of children, disabled persons, etc.

3. Remove the boxes containing the disc brushes and squeegee body from the machine.

 **CAUTION:** it is recommended to wear the appropriate PPE (Personal Protective Equipment), suitable for the work to be carried out.

4. Place a descent ramp at the rear of the machine.

 **WARNING:** the descent ramp must have an inclination and a capacity such as not to damage the machine or be damaged during the transit of the machine, contact the FIMAP service centre technician to obtain the net weight of the machine.

5. The machine is secured to the footboard with wedges that lock the wheels; remove these wedges.
6. Check the main switch is on "0". If it isn't, make a quarter turn anti-clockwise with the key (1) (**Fig.1**).
7. Remove the key from the instrument panel.
8. Position yourself to the side of the machine, grasp the handle (2) and turn the battery compartment lid (3) to its service position (**Fig.2**).

 **ATTENTION:** to prevent the lid from turning, insert the retainer (4) into the slot (5) (**Fig.3**).

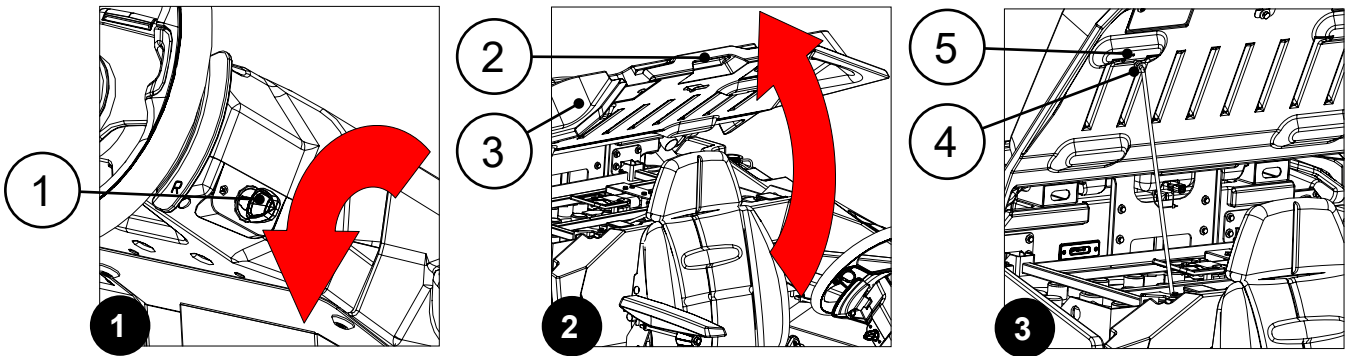

⚠ ATTENTION: the following operations must be carried out by qualified personnel. An incorrect connection of the connector may cause a malfunction of the device.

9. Connect the connector of the battery pad trolley to the machine's main system connector.
10. Grasp the battery compartment lid and turn it to its working position.

i N.B.: release the retainer before turning the lid.

11. Sit on the driver's seat.
12. Insert the key (1) in the main switch (2) on the instrument panel (**Fig.4**).
13. Bring the main switch to position "I" by turning the key (1) a quarter turn clockwise (**Fig.5**).
14. Check that the working mode activated on the machine is TRANSFER, otherwise press the button (6) on the control display (**Fig.6**), see ["DS SELECTOR \(DRIVE SELECT\)"](#) on page 70.

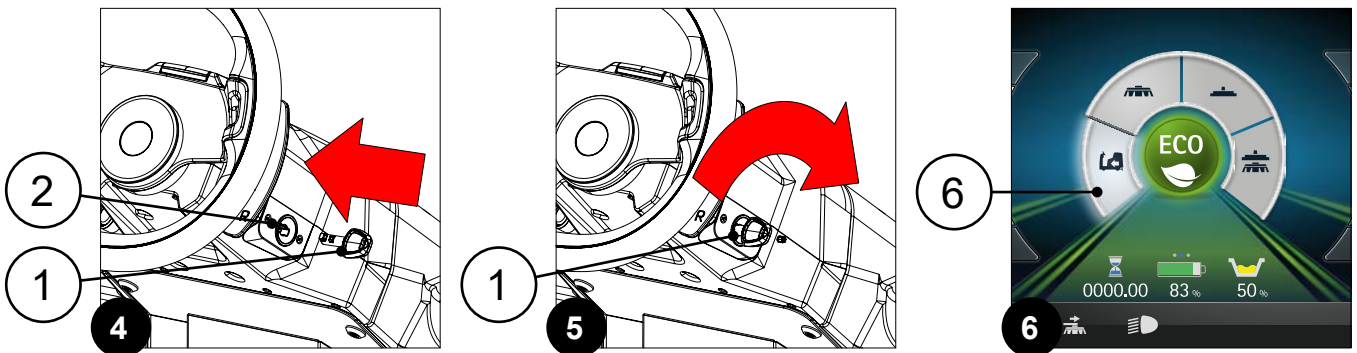

15. Engage the "REVERSE GEAR ACTIVATION/DEACTIVATION" lever (7) underneath the steering wheel (**Fig.7**).
16. Press the drive pedal (8) (**Fig.8**) to start the machine moving in reverse.

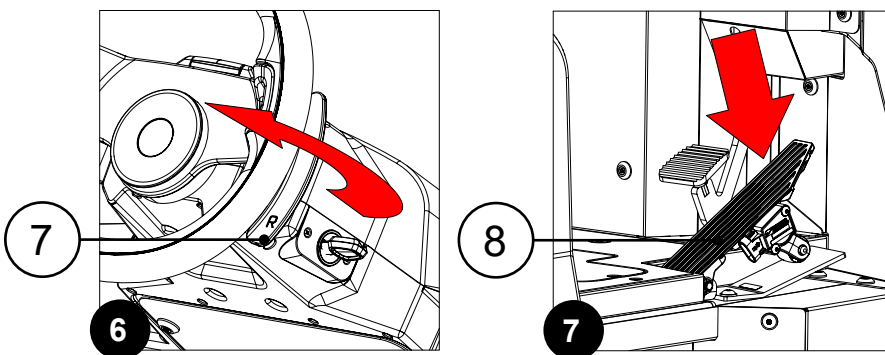

17. Drive the machine down the ramp.

⚠ ATTENTION: during this operation, check there are no people or objects near the machine.

18. Set the main switch to its "0" position, and turn the key (1) a quarter turn anti-clockwise (**Fig. 1**).
19. Remove the key from the instrument panel.
20. Position yourself to the side of the machine, grasp the handle (2) and turn the battery compartment lid (3) to its service position (**Fig.2**).

⚠ ATTENTION: to prevent the lid from turning, insert the retainer (4) into the slot (5) (**Fig.3**).

⚠ ATTENTION: the following operations must be carried out by qualified personnel. An incorrect connection of the connector may cause a malfunction of the device.

21. Disconnect the backup battery trolley connector from the main machine system connector.
22. Grasp the battery compartment lid and turn it to its working position.

i N.B.: release the retainer before turning the lid.

MACHINE SAFETY

To ensure that work is carried out in the best safety conditions, proceed as follows:

⚠ CAUTION: it is recommended to wear the appropriate PPE (Personal Protective Equipment), suitable for the work to be carried out.

1. Open the right inspection door (1) (**Fig.1**).
2. Check that the right gearmotor electric brake is activated. The lever (2) must not be in its locked position, otherwise, unlock it by pulling it towards you and moving it downwards (**Fig.2**).

⚠ DANGER: the electric brake is considered to be engaged when the hexagonal column (3) is free to move within the hole in the bracket (4) located in the frame (**Fig.3**).

⚠ DANGER: the electric brake is considered to be disengaged when the hexagonal column (3) is resting on the bracket (4) located in the frame (**Fig.3**).

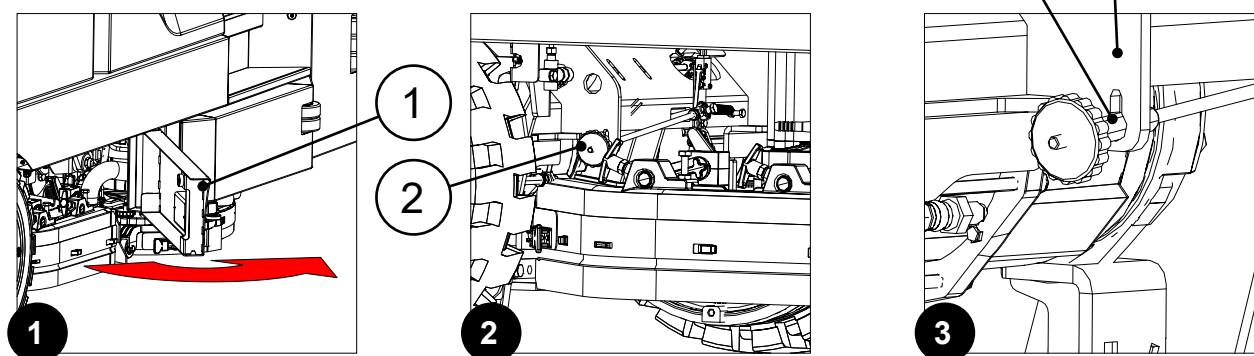

3. Check that also the right gearmotor electric brake is activated. The lever (2) must not be in its locked position, otherwise, unlock it by pulling it towards you and moving it downwards (**Fig.4**).
4. Make sure the solution tank is empty. If this is not the case, empty it. See [“EMPTYING THE SOLUTION TANK” on page 123](#) on page .
5. Make sure the recovery tank is empty. If this is not the case, empty it. See [“DRAINING THE RECOVERY TANK” on page 121](#).
6. Sit on the driver's seat.

7. Insert the key (5) into the main switch on the right side of the steering column (Fig.5).
8. Set the main switch to "I" by turning the key a quarter turn clockwise (Fig.5).

⚠ ATTENTION: If the electric brake is not properly engaged, the alarm symbol will appear on the control display (Fig. 6) and will remain visible until all the electric brakes have been properly engaged.

i N.B.: when the electric brake is deactivated, traction is inhibited.

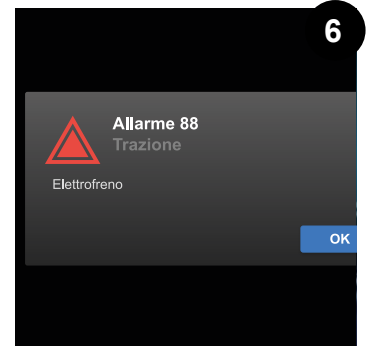
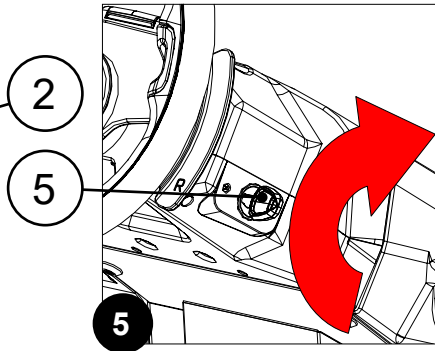
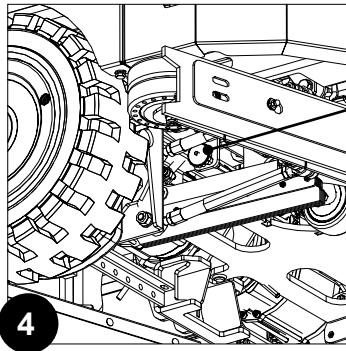

9. Check that the working mode activated on the machine is TRANSFER, otherwise press the button (6) on the control display (Fig.7), see ["DS SELECTOR \(DRIVE SELECT\)"](#) on page 70.
10. Check that the sweeper working mode is deactivated; if not, press the button (7) on the control display (Fig.7), see ["DS SELECTOR \(DRIVE SELECT\)"](#) on page 70.
11. Bring the main switch to the "0" position by making a quarter turn anti-clockwise with the key (5) (Fig.8).
12. Remove the key from the instrument panel.

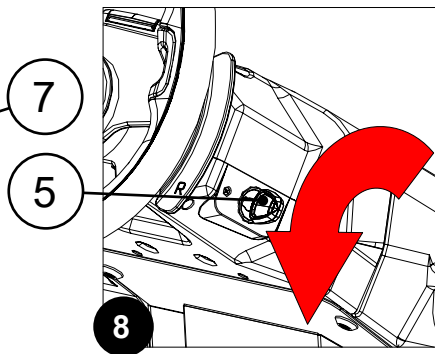
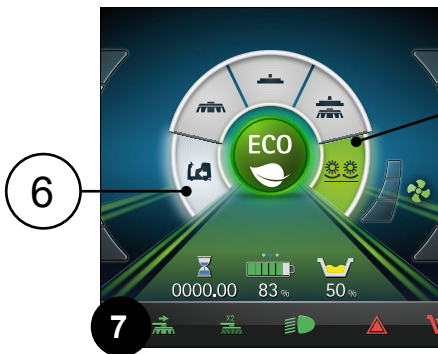

13. Get off the machine.
14. Remove the key from the instrument panel.
15. Get off the machine.

⚠ CAUTION: do not position your foot above the side brush head carter while the machine is descending.

16. Grasp the handle (8) and turn the battery compartment cover (9) to the service position (Fig.9).

⚠ ATTENTION: to prevent the lid from turning, insert the retainer (10) into the slot (11) (Fig.10).

⚠ ATTENTION: the following operations must be carried out by qualified personnel. Incorrect operations could result in machine malfunctions.

17. Disconnect the machine's electrical system wiring connector (12) from the connector on the power cable coming from the battery box (Fig. 11).

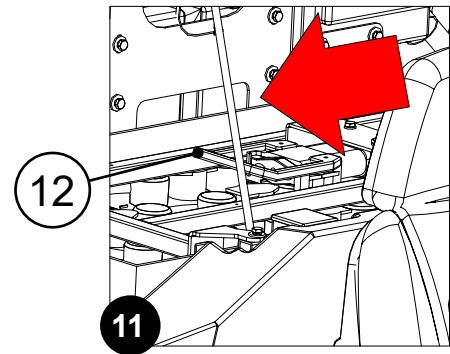
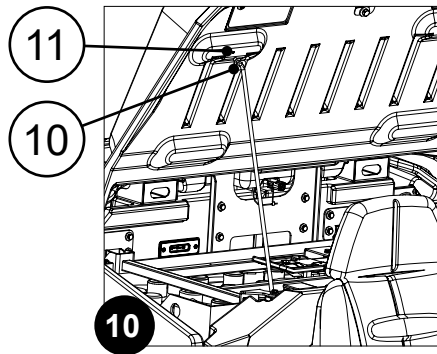
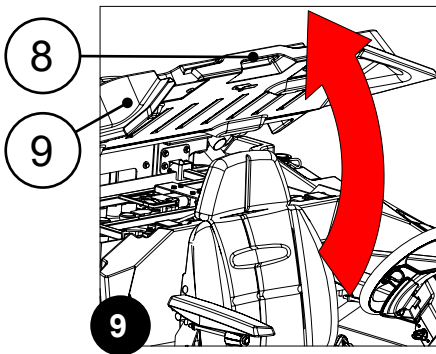

18. Grasp the battery compartment lid and turn it to its working position.

i **N.B.:** release the retainer before turning the lid.

19. Set the detergent solution flow to its OFF position by turning the lever (13) under the operator's seat clockwise (Fig. 12).

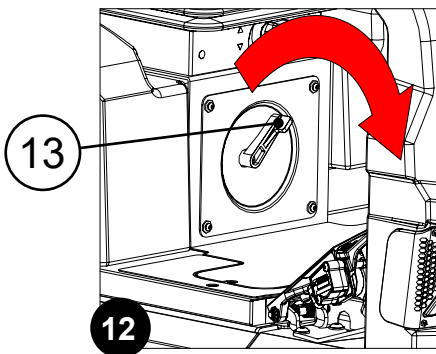

HOW TO MOVE THE MACHINE

The procedure for transporting the machine full safely is as follows:

CAUTION: it is recommended to wear the appropriate PPE (Personal Protective Equipment), suitable for the work to be carried out.

1. Open the right inspection door (1) (Fig.1).
2. Check that the right gearmotor electric brake is activated. The lever (2) must not be in its locked position, otherwise, unlock it by pulling it towards you and moving it downwards (Fig.2).

! DANGER: the electric brake is considered to be engaged when the hexagonal column (3) is free to move within the hole in the bracket (4) located in the frame (Fig.3).

! DANGER: the electric brake is considered to be disengaged when the hexagonal column (3) is resting on the bracket (4) located in the frame (Fig.3).

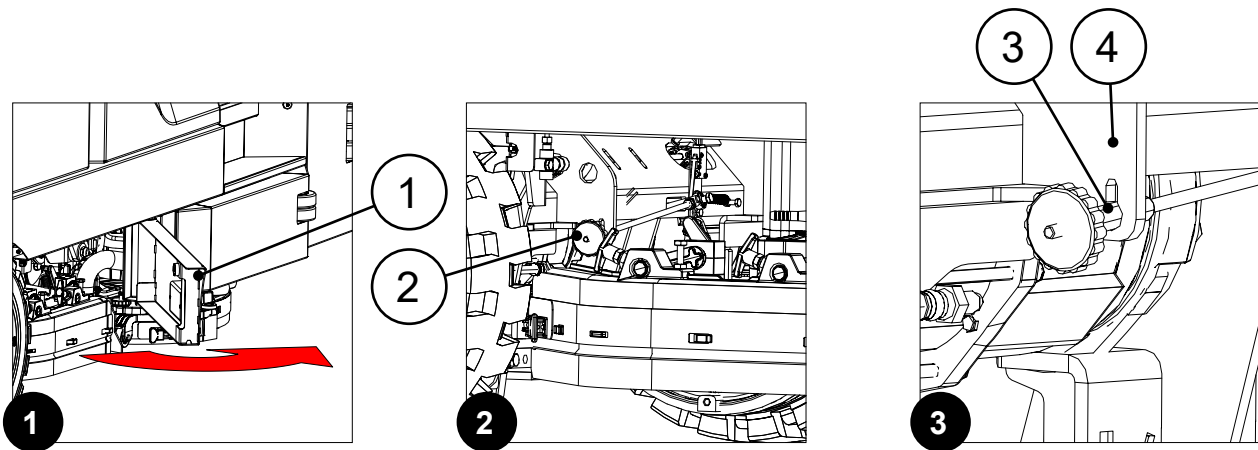

3. Check that also the right gearmotor electric brake is activated. The lever (2) must not be in its locked position, otherwise, unlock it by pulling it towards you and moving it downwards (Fig.4).
4. Make sure the solution tank is empty. If this is not the case, empty it. See [“EMPTYING THE SOLUTION TANK” on page 123](#) on page .
5. Make sure the recovery tank is empty. If this is not the case, empty it. See [“DRAINING THE RECOVERY TANK” on page 121](#).
6. Sit on the driver’s seat.
7. Insert the key (5) into the main switch on the right side of the steering column (Fig.5).
8. Set the main switch to "I" by turning the key a quarter turn clockwise (Fig.5).

⚠ WARNING: If the electric brake is not properly engaged, the alarm symbol will appear on the control display (Fig. 6) and will remain visible until all the electric brakes have been properly engaged.

i N.B.: when the electric brake is deactivated, traction is inhibited.

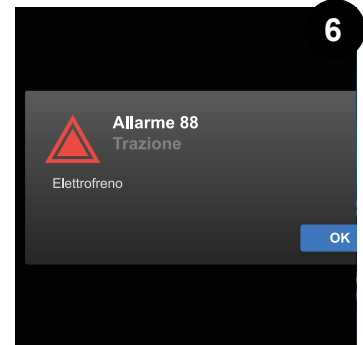
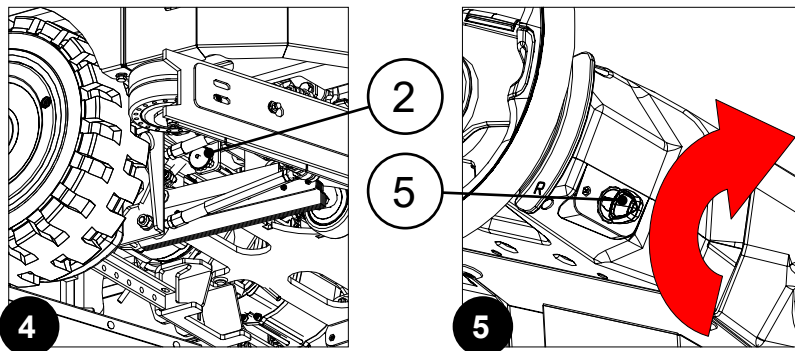

9. Check that the working mode activated on the machine is TRANSFER, otherwise press the button (6) on the control display (Fig.7), see [“DS SELECTOR \(DRIVE SELECT\)” on page 70](#).
10. Check that the sweeper working mode is deactivated; if not, press the button (7) on the control display (Fig.7), see [“DS SELECTOR \(DRIVE SELECT\)” on page 70](#).
11. Bring the main switch to the "0" position by making a quarter turn anti-clockwise with the key (5) (Fig.8).
12. Remove the key from the instrument panel.

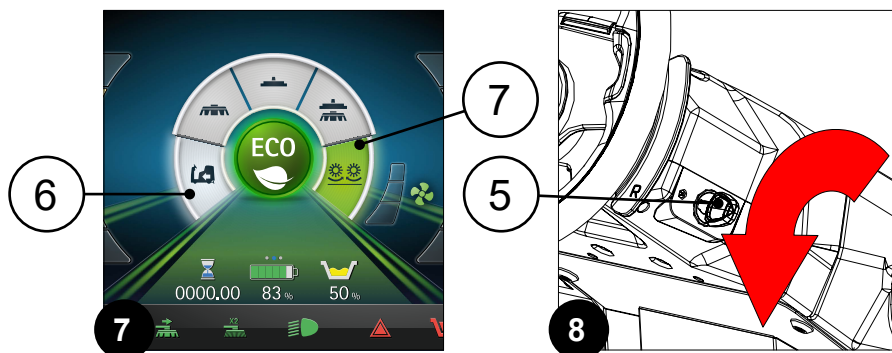

13. Get off the machine.
14. Remove the key from the instrument panel.
15. Get off the machine.

CAUTION: do not position your foot above the side brush head carter while the machine is descending.

16. Grasp the handle (8) and turn the battery compartment cover (9) to the service position (**Fig.9**).

ATTENTION: to prevent the lid from turning, insert the retainer (10) into the slot (11) (**Fig.10**).

ATTENTION: the following operations must be carried out by qualified personnel. Incorrect operations could result in machine malfunctions.

17. Disconnect the machine's electrical system wiring connector (12) from the connector on the power cable coming from the battery box (**Fig. 11**).

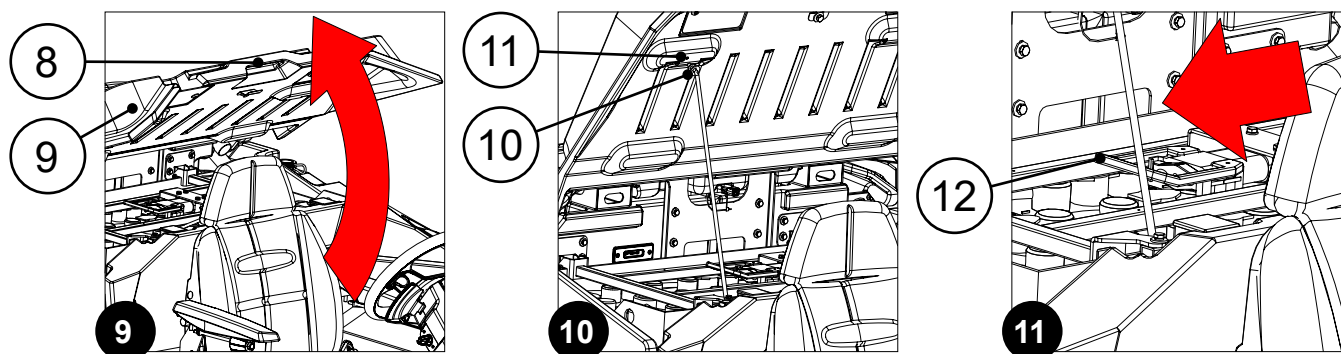

18. Grasp the battery compartment lid and turn it to its working position.

N.B.: release the retainer before turning the lid.

19. Set the detergent solution flow to its OFF position by turning the lever (13) under the operator's seat clockwise (**Fig. 12**).

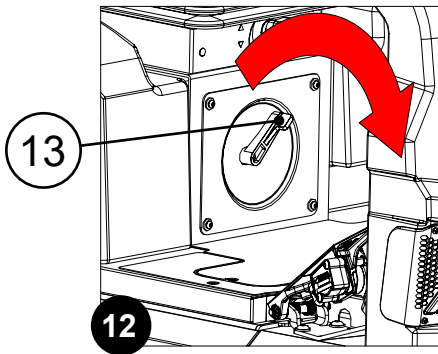

20. Secure the machine to the means of transport using an appropriate number and type of fastening elements, based on its weight and size.

CAUTION: secure the machine according to the directives in force in the country of use, so that it cannot slide or tip over.

N.B.: the anchor points to be used to safely secure the machine are indicated on the machine itself.

HOW TO MOVE THE MACHINE WITH THE TRACTION IN NEUTRAL

The phases for moving the machine with the traction system in neutral are as follows:

1. Perform all the operations required to secure the machine. See [“MACHINE SAFETY” on page 35](#).
2. Open the right inspection door (1) (**Fig.1**).
3. Deactivate the right gearmotor electric brake, the lever (2) must be in its locked position, otherwise, lock it by pulling it towards you and moving it up (**Fig.2**).

DANGER: the electric brake is considered to be disengaged when the hexagonal column (3) is resting on the bracket (4) located in the frame (**Fig.3**).

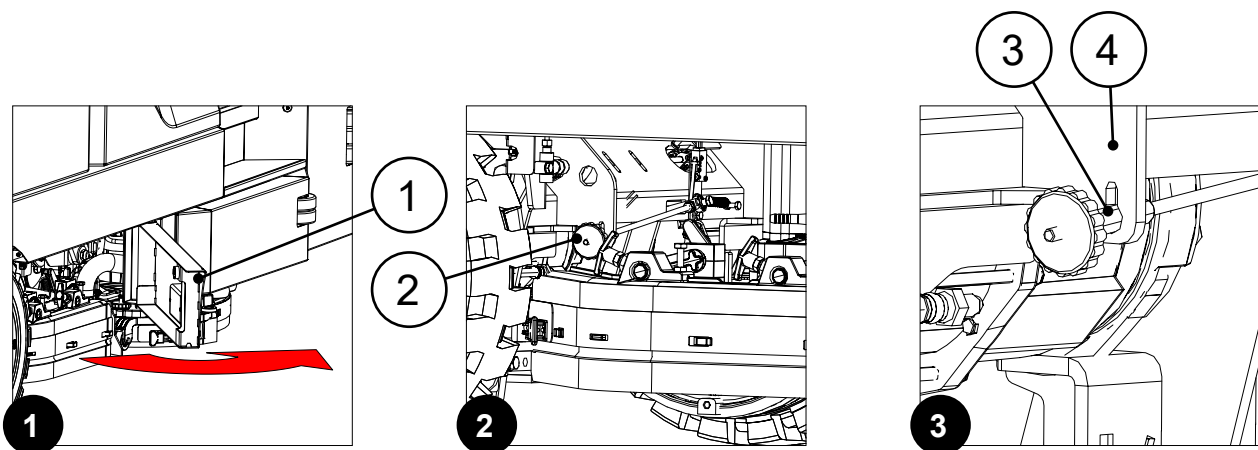

4. Deactivate the left gearmotor electric brake, the lever (2) must be in its locked position; otherwise, lock it by pulling it towards you and moving it up.

DANGER: the electric brake is considered to be disengaged when the hexagonal column (3) is resting on the bracket located in the frame (**Fig.3**).

5. Fix the machine to the drive elements.

⚠ CAUTION: Use the type of drive element most suitable for the machine weight, see the transport weight parameter in the TECHNICAL DATA table, see [“TECHNICAL DATA” on page 15.](#)

🖐 N.B.: the anchor points to be used to safely secure the machine are indicated on the machine itself.

TRACTION ELECTRIC BRAKE ACTIVATION

The phases for activating the traction electric brake are as follows:

🖐 CAUTION: it is recommended to wear the appropriate PPE (Personal Protective Equipment), suitable for the work to be carried out.

1. Open the right inspection door (1) (**Fig.1**).
2. Activate the right gearmotor electric brake, the lever (2) must not be in its locked position, otherwise, release it by pulling it towards you and moving it down (**Fig.2**).

⚠ DANGER: the electric brake is considered to be engaged when the hexagonal column (3) is free to move within the hole in the bracket (4) located in the frame (**Fig.3**).

⚠ DANGER: the electric brake is considered to be disengaged when the hexagonal column (3) is resting on the bracket (4) located in the frame (**Fig.3**).

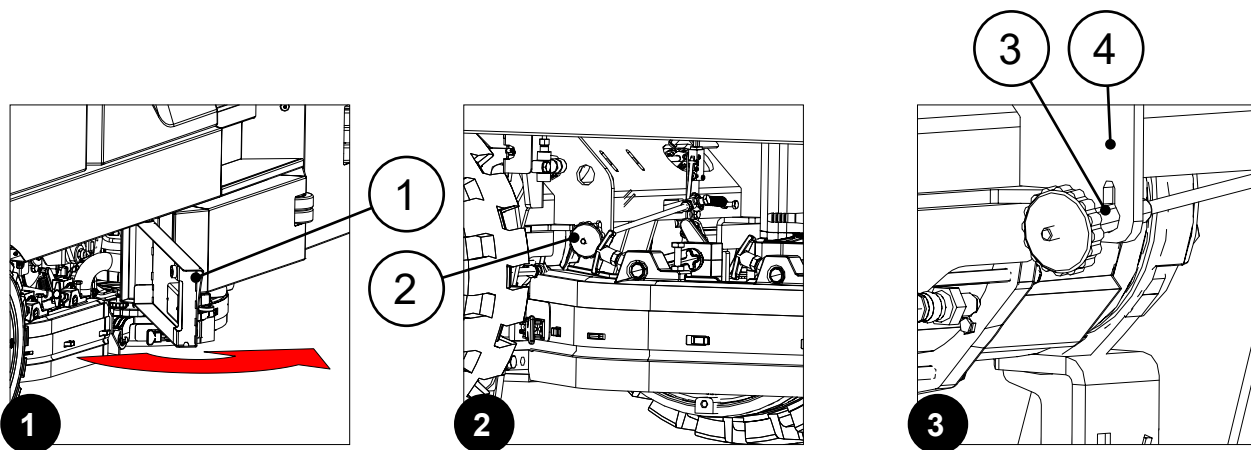

3. Close the left inspection door (1).
4. Activate the left gearmotor electric brake, the lever (2) must not be in its locked position, otherwise, release it by pulling it towards you and moving it down (**Fig.4**).

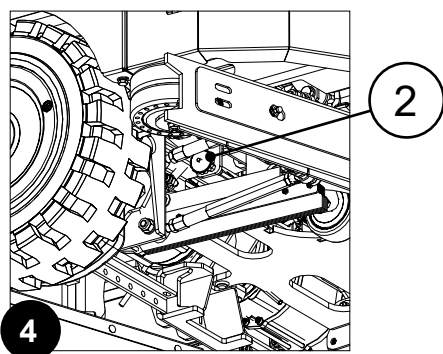

TYPE OF BATTERY PACK TO BE USED

Code	Type	Voltage (V)	Work (Ah _{C5})
454282	traditional lead	36	775
455908	pure lead	36	500
456224	lithium	36	720

For good work performance, the machine must be powered at 36V with a dedicated battery pack. It is recommended to use the traditional lead 36V 775 Ah_{C5} battery pack.

The dimensions of the battery holder compartment are: 930x800x430 mm (length x height x width).

 **N.B.:** the function board in the machine is programmed by the factory to work with the following type of battery: 36Pb80, to change please [“MODIFICARE LA TIPOLOGIA DI BATTERIA SELEZIONATA \(GENERAL - BATTERY\)”](#) on page 26 of the “OPERATOR INTERFACE CONFIGURATION MANUAL” which can be downloaded from the site www.fimap.com

BATTERY BOX MAINTENANCE AND DISPOSAL

For battery box maintenance and recharging, follow the instructions contained in the document provided by the battery manufacturer.

When the battery box is dead, it must be disconnected by a technician from a FIMAP service centre; using a suitable lifting device, remove the battery box from the machine and take it to a suitable disposal centre.



N.B.: used batteries, which are classified as hazardous waste, must be returned to a legally authorised waste disposal authority.

INSERTING THE BATTERY BOX IN THE MACHINE

To insert the battery box in the machine, contact a FIMAP service centre technician.



WARNING: FIMAP declines all responsibility for any damage to property or injury persons in the event that the batteries are replaced by an unauthorized technician.

RECHARGING THE BATTERY BOX

The battery box must be charged prior to first use and whenever it no longer provides sufficient power to perform the desired work activities.



WARNING: by default the function board present in the machine is set for a Pb80 type battery, contact a FIMAP service centre to make the change.



N.B.: Carefully read the User and Maintenance Manual for the battery box you wish to use before charging.

1. Bring the machine to the battery recharging area.



ATTENTION: Park the machine in an enclosed place, on a flat and level surface; near the machine there must be no objects that could either damage it, or be damaged through contact with it.



ATTENTION: the room where the batteries are recharged must be adequately ventilated to prevent the accumulation of gases that leak from batteries.



WARNING: the place designated for this operation must comply with current regulations concerning safety at work and current environmental protection regulations.

 **CAUTION:** it is recommended to wear the appropriate PPE (Personal Protective Equipment), suitable for the work to be carried out.

2. Perform all the operations required to secure the machine. See [“MACHINE SAFETY” on page 35.](#)
3. Position yourself to the side of the machine, grasp the handle (1) and turn the battery compartment lid (2) to its service position (**Fig.1**).

 **ATTENTION:** to prevent the lid from turning, insert the retainer (3) into the slot (4) (**Fig.2**).

 **ATTENTION:** the following operations must be carried out by qualified personnel. An incorrect connection of the connector may cause a malfunction of the device.

4. Connect the battery charger cable connector (5) to the connector on the power cable coming from the battery box (**Fig.3**).

 **N.B.:** The battery charger coupling connector comes inside the bag containing this instruction booklet, and must be assembled on the battery charger cables as indicated in the instructions.

 **WARNING:** before connecting the battery box to the battery charger, make sure it is suitable for the battery box you want to charge.

 **N.B.:** carefully read the user and maintenance instructions for the battery charger to be used for charging.

 **CAUTION:** keep the battery compartment lid open for the entire duration of the battery box recharging cycle in order to allow any fumes to escape.

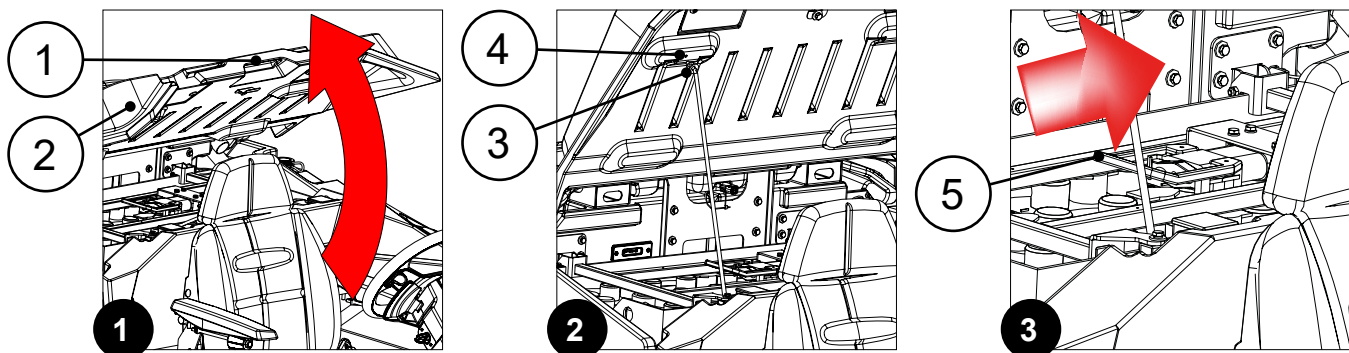

5. Connect the battery charger cable to the power supply socket.
6. Once the charging cycle has been completed, disconnect the battery charger cable connector (5) from the connector on the power cable coming from the battery box.
7. Connect the connector on the machine's electrical system wiring to the connector on the power cable coming from the battery box.
8. Grasp the battery compartment lid and turn it to its working position.





 **N.B.:** release the retainer before turning the lid.

ADJUSTMENT OF THE DRIVER'S SEAT (STANDARD SEAT)



The proper adjustment of the driving position provides a greater sense of comfort when using the machine.

CORRECT POSITION ON THE SEAT: make sure you sit upright and that your back and that your lower back and spine are at 90°.

LONGITUDINAL SEAT ADJUSTMENT: The seat should always be positioned using the pedals as a reference. To adjust the seat, use the lever located under it.

-  **N.B.:** the distance should be adjusted so that the knees are slightly bent (about 120°) when the pedals are fully pressed to the floor.
-  **N.B.:** adjust the distance of the seat so that the brake pedal reaches the end of its stroke when pressed.
-  **N.B.:** your feet should be positioned keeping your heels on the footboard; the pedals should be pressed using the part of the foot directly behind your toes.
-  **N.B.:** the ideal position is that which allows you to grip the steering wheel correctly with the palms of your hands slightly below shoulder level. With a good grip on the steering wheel, the elbows should be bent by about 120°. They should be at least 30 cm between the middle of the steering wheel and our breastbone. In any case, this distance should be no more than 45 cm.

ADJUSTING THE ARMRESTS (OPTIONAL): the armrests should be inclined to make using the machine comfortable.

-  **N.B.:** to adjust the armrest, use the runner located under it.
-  **N.B.:** taking the right armrest as a reference, if the wheel is turned outwards the inclination of the armrest is increased. Taking the left armrest as a reference, if the wheel is turned inwards the inclination of the armrest is increased.

WEARING THE SAFETY BELT (OPTIONAL) CORRECTLY: the machine comes equipped with a sub-abdominal safety device, which allows the operator to remain anchored to the driver's seat. To secure the safety belt, you must first be sitting in the driver's seat; take the mobile part of the belt, wrap it round the abdomen and insert the mobile part in the slit in the fixed part.

-  **N.B.:** adjust the horizontal part of the belt so it is as tight as possible around the pelvis. The belt should be pulled and put as low as possible on the pelvis bone, and not on the belly.

ADJUSTMENT OF THE DRIVER'S SEAT (COMFORT SEAT)

When adjusting the driver's seat with the comfort seat, follow the instructions in the document provided by the seat manufacturer.

INSERTING WATER SYSTEM FILTER

Before using the machine for the first time the water system filter needs to be reset, for shipping reasons the filter cartridge and the cap have been removed.

To insert the filter cartridge in the water system filter cap proceed as follows:

1. Take the machine to the maintenance area.
2. Perform all the operations required to secure the machine. See [“MACHINE SAFETY” on page 35.](#)

 **CAUTION:** it is recommended to wear the appropriate PPE (Personal Protective Equipment), suitable for the work to be carried out.

3. Close the tap's outlet flow, and turn the lever (1) on the front of the driver's seat clockwise (**Fig.1**).
4. Stand on the left side of the machine.
5. Open the left lateral inspection door (2) (**Fig.2**).
6. Insert the filter cartridge (3) in the housing on the cap (4) (**Fig.3**).

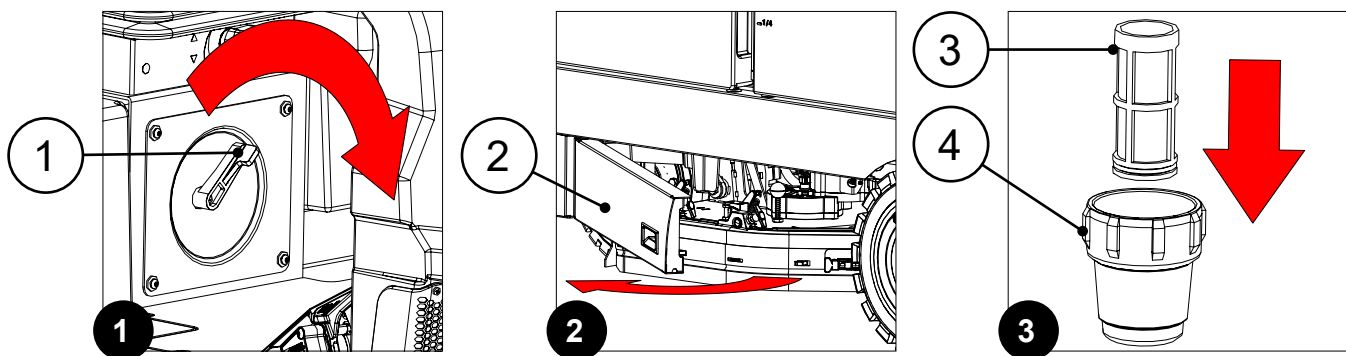

 **N.B.:** The O-ring gasket in the filter cartridge should be inserted into its seat in the cap.

7. Screw the cap (4) onto the body of the detergent solution filter (**Fig.4**).

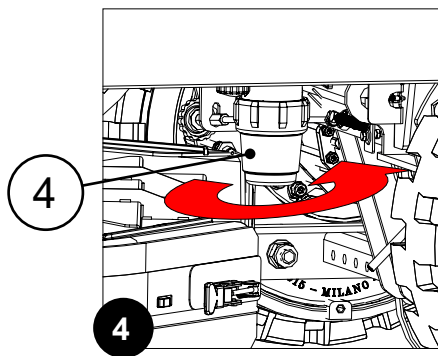

DETERGENT SOLUTION

Proceed as follows to fill the solution tank with water:

1. Take the machine to the usual place for filling the solution tank.
2. Perform all the operations required to secure the machine. See [“MACHINE SAFETY” on page 35](#).



CAUTION: it is recommended to wear the appropriate PPE (Personal Protective Equipment), suitable for the work to be carried out.

3. Close the tap's outlet flow, and turn the lever (1) on the front of the driver's seat clockwise (**Fig.1**).
4. Open the left lateral inspection door (2) (**Fig.2**).
5. Make sure that the cap (3) on the water system filter body (4) is closed. If not, close it (**Fig.3**).

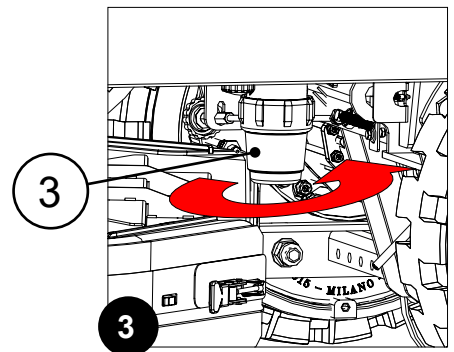
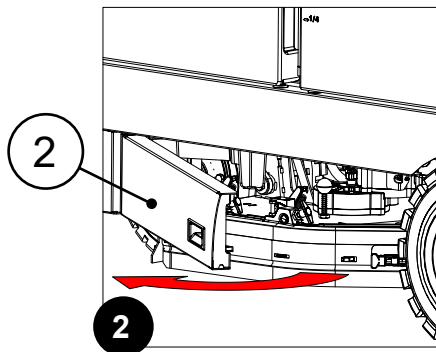
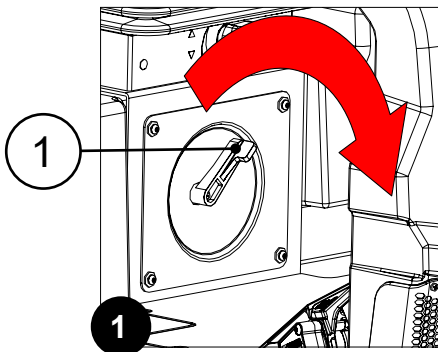

6. Close the left inspection door.
7. Remove the solution tank filler cap (5) (**Fig.4**).
8. Check that the filter (6) under the cap is positioned correctly (**Fig.5**) in order to prevent impurities and dirt from getting inside, which can cause the machine's water system to malfunction.
9. Fill the solution tank.



N.B.: the amount of solution inside the tank is indicated by the coloured ball inside the level tube (7) on the left-hand side of the machine (**Fig.6**).

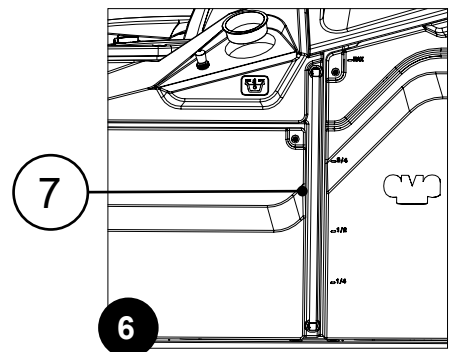
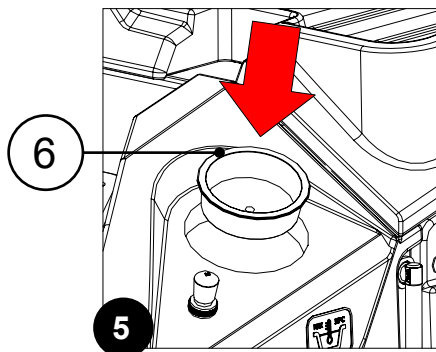
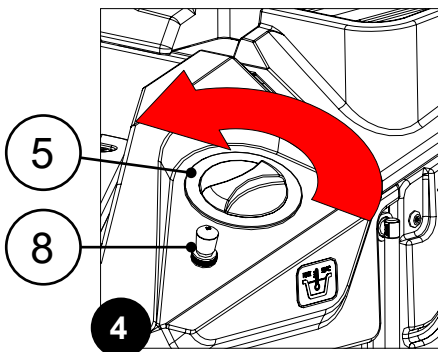

N.B.: the solution tank can also be filled with the quick-fill system (FFF). Simply connect the water hose to the quick-fit hose connector (8) on the machine (**Fig. 4**), and remember to remove the cap (5) to vent the air.



N.B.: fill with clean water, at a temperature no higher than 50°C (122°F) and no lower than 10°C (50°F).

For the versions without the automatic detergent dosing system (versions without FSS), after filling the solution tank with clean water, add the liquid detergent to the tank in the concentration and manner indicated on the detergent manufacturer's label.

i **N.B.:** to prevent an excessive amount of foam from forming, which could damage the suction motor, use the minimum percentage of detergent required.

CAUTION: protective gloves should always be worn when handling detergents or acidic or alkaline solutions, to avoid serious hand injuries.

ATTENTION: always use detergents which have a manufacturer's label that indicates that they are suitable for use with floor scrubbing machines. Do not use acid or alkaline products or solvents without this indication.

ATTENTION: in order to avoid damaging the machine's water system, acidic or alkaline maintenance detergents can be used, as long as they have pH values between 4 and 10, and do not contain: oxidising agents, chlorine or bromine, formaldehyde, mineral solvents.

ATTENTION: Always use low-foam detergent. To avoid the production of foam, put a minimum quantity of antifoam liquid in the recovery tank before starting to clean. Do not use pure acids.

For versions with the automatic detergent dosing system (versions with the FSS system), fill the solution tank with clean water and then proceed as follows:

1. Perform all the operations required to secure the machine. See [“MACHINE SAFETY” on page 35.](#)

CAUTION: protective gloves should always be worn when handling detergents or acidic or alkaline solutions, to avoid serious hand injuries.

2. Grasp the handle (1) and turn the battery compartment cover (2) to the service position (**Fig.1**).

ATTENTION: to prevent the lid from turning, insert the retainer (3) into the slot (4) (**Fig.2**).

3. Remove the detergent tank cap (5) (**Fig.3**).

4. Fill the tank with the desired detergent. The amount present in the detergent tank is indicated by the two level bulbs (6) (**Fig.3**).

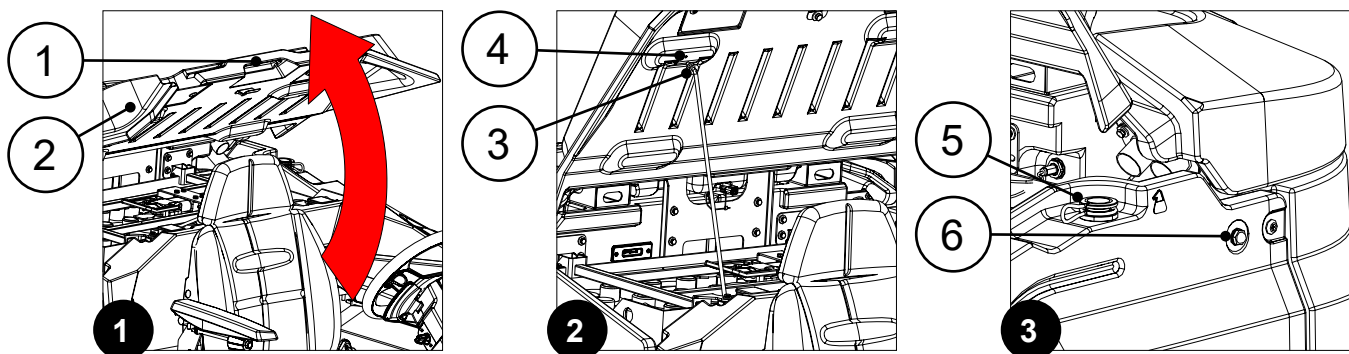



i **N.B.:** The upper bulb indicates the detergent tank's maximum fill level; the lower bulb indicates the minimum level, below which the automatic system will not function properly.

ATTENTION: always use detergents which have a manufacturer's label that indicates that they are suitable for use with floor scrubbing machines. Do not use acid or alkaline products or solvents without this indication.

 **WARNING:** the dosing system is particularly suitable for frequent maintenance cleaning operations. Acidic or alkaline maintenance detergents can be used, as long as they have pH values between 4 and 10, and do not contain: oxidising agents, chlorine or bromine, formaldehyde, mineral solvents.

 **N.B.:** the detergents used must be suitable for use with scrubbing machines.

 **N.B.:** wash the circuit with water after use if the system is not used daily. The system can be excluded.

 **N.B.:** In case of sporadic use of detergents with pH between 1-3 or 11-14, use the floor scrubbing machine in the traditional way by adding the detergent in the clean water tank and excluding the dosing circuit.

 **ATTENTION:** Always use low-foam detergent. To avoid the production of foam, put a minimum quantity of antifoam liquid in the recovery tank before starting to clean. Do not use pure acids.

5. Close the cap (5) correctly to prevent liquid coming out when working.

ASSEMBLY OF BRUSHES OR DRIVE DISCS (DISCOID SCRUBBING VERSION)

To mount the brushes or drive discs on the brush head without using the brush centering kit, proceed as follows:

1. Take the machine to the maintenance area.
2. Activate the "SERVICE" function, see ["SERVICE FUNCTION" on page 86](#).
3. Perform all the operations required to secure the machine. See ["MACHINE SAFETY" on page 35](#).

CAUTION: it is recommended to wear the appropriate PPE (Personal Protective Equipment), suitable for the work to be carried out.

4. Open the left inspection door (1) (**Fig.1**).
5. Set the fastening anchors (2) on the side splash guard support to the service position, move them upwards, and turn them a quarter turn clockwise (**Fig.2**).
6. Extract the left side splash guard support (3) from the brush head (**Fig.3**).

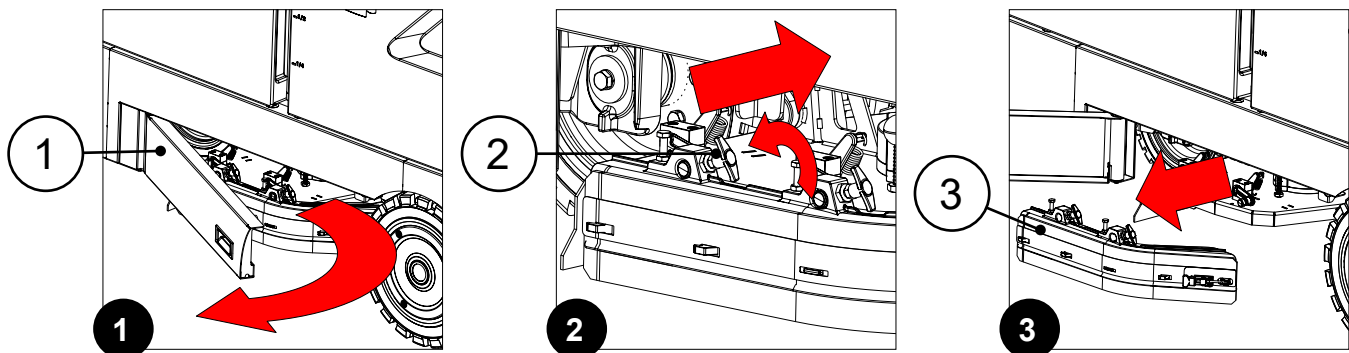

7. Insert the brush (4) in the brush holder plate (5) (**Fig.4**).
8. Turn the brush anti-clockwise until the three buttons (6) on the brush enter the notches (7) on the brush holder plate (**Fig.5**).
9. Turn the brush quickly and firmly in order to push the button towards the coupling spring (8) and lock it in place (**Fig.5**).

N.B.: The image in **Fig.6** indicates the direction of rotation for coupling the left brush; the right brush must be turned in the opposite direction.

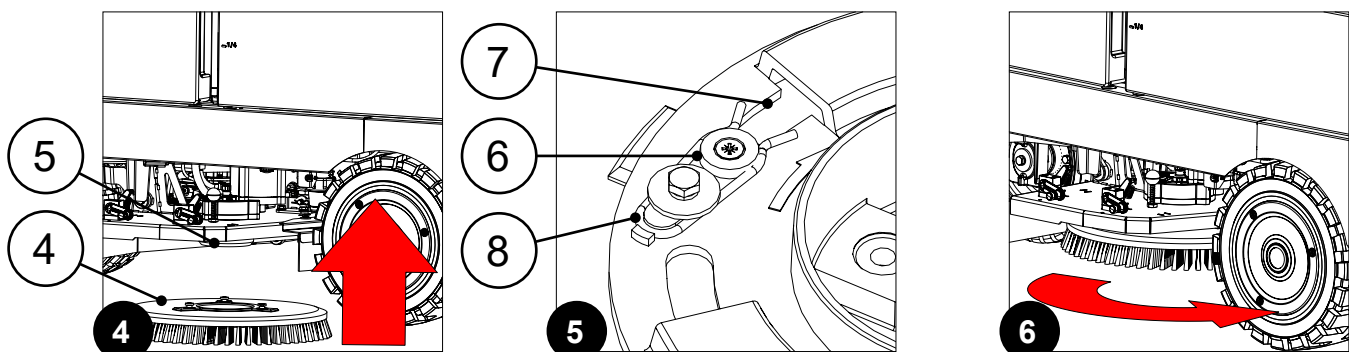

10. Insert the left side splash guard support (3) in the brush head (**Fig.7**).

N.B.: Insert the pin (9) in the hole (10) of the side splash guard support (**Fig.8**).

11. Set the fastening anchors (2) to their working position, turn them a quarter turn anti-clockwise, and move them downwards (**Fig.9**).

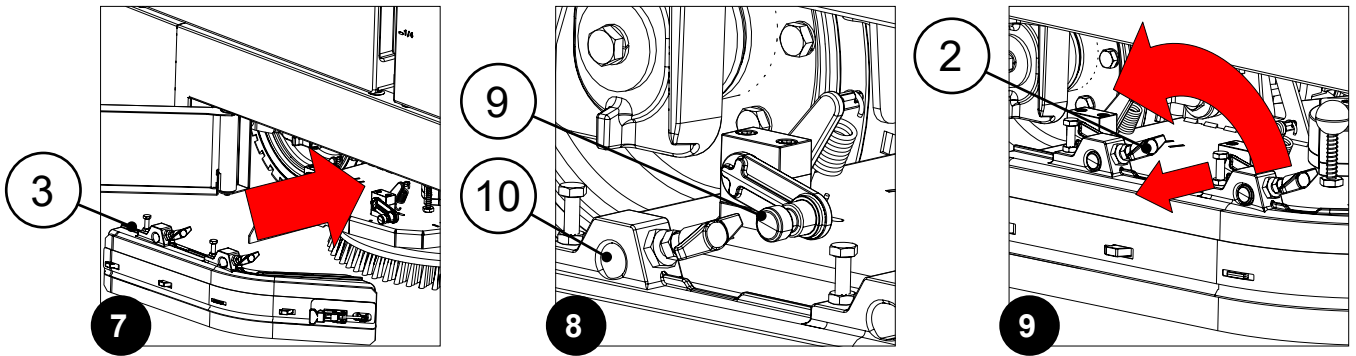

12. Close the left inspection door.
13. Repeat the operations carried out for the right-hand brush too.

i **N.B.:** The side splash guard supports come pre-adjusted. However, if they should need to be adjusted, see [“ADJUSTMENT OF BRUSH HEAD SIDE SPLASH GUARD \(DISCOID SCRUBBING VERSION\)” on page 156.](#)

To mount the brushes or drive discs on the brush head using the brush centering kit, proceed as follows:

1. Place the machine in the TRANSFER working mode, see [“DS SELECTOR \(DRIVE SELECT\)” on page 70 .](#)
2. Activate the service function, press the BRUSH UNCOUPLING button (2) on the control panel (**Fig.2**).

i **N.B.:** with the service function, both the brush head and the squeegee are automatically moved to the intermediate position (referred to as the extra position) by the machine.

i **N.B.:** once the service sequence has been activated, it is not possible to activate other functions or move the machine.

⚠ CAUTION: make sure that no people or objects are in the machine's vicinity during this operation. Take the machine to the maintenance area.

🧤 CAUTION: it is recommended to wear the appropriate PPE (Personal Protective Equipment), suitable for the work to be carried out.

3. Open the left inspection door (3) (**Fig.3**).

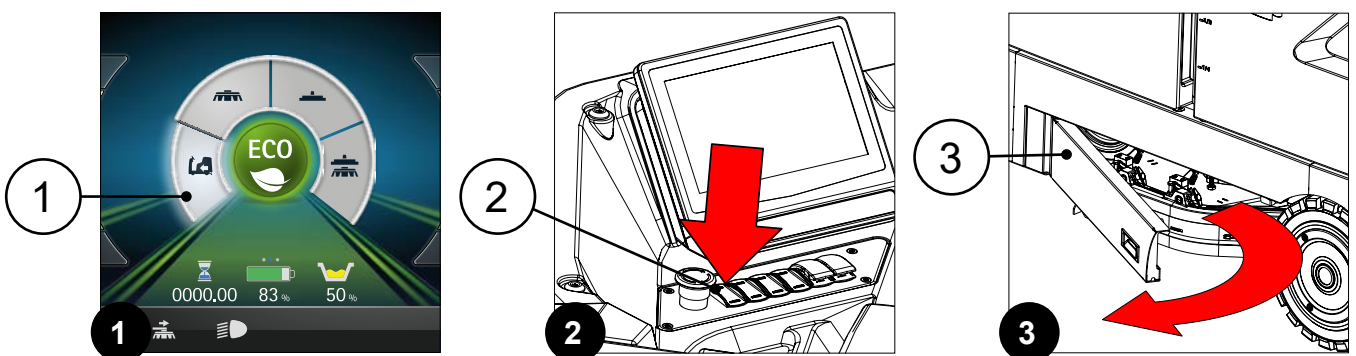

4. Set the fastening anchors (4) on the side splash guard support to the service position, move them upwards, and turn them a quarter turn clockwise (**Fig.4**).
5. Extract the left side splash guard support (5) from the brush head (**Fig.5**).
6. Position the brush that you wish to use on the floor.

7. Activate the brush centering kit, moving the key (6) present in the brush head body (**Fig.6**).

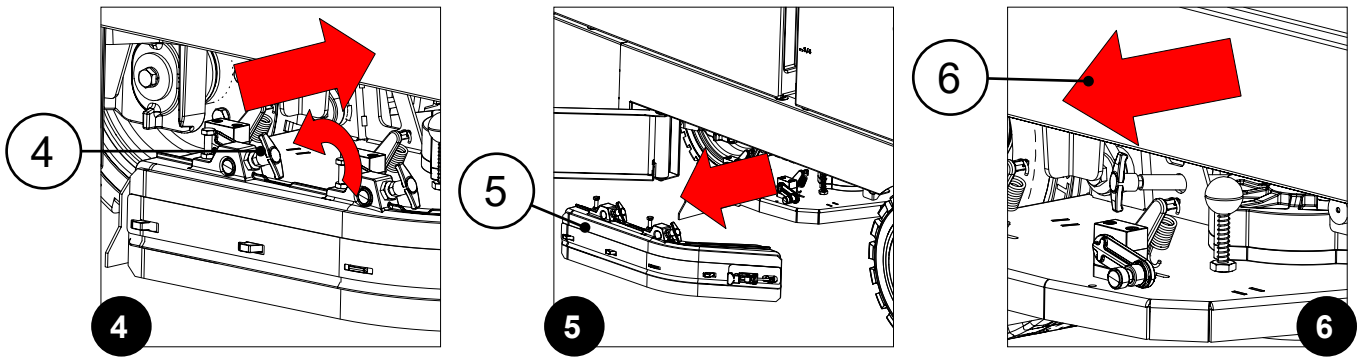

8. Move the brush into the working position and push it into the machine until it touches the centering kit.

9. Release the key (6).

10. Repeat steps number three to nine for the right-hand brush.

11. Sit on the driver's seat.

12. Activate the brush coupling function, pressing the button (2) on the control panel for more than 3 seconds (**Fig.2**)

i **N.B.:** in the brush assembly function, the brush head will be automatically brought into the working position; the jacks in the brush head will be activated by impulses to allow the brush to move into position and engage with the brush head itself.

i **N.B.:** once the service sequence has been activated, it is not possible to activate other functions or move the machine.

! **CAUTION:** make sure that no people or objects are in the machine's vicinity during this operation. Take the machine to the maintenance area.

13. Once the brushes are attached, insert the left side splash guard support (5) in the brush head (**Fig.7**).

i **N.B.:** Insert the pin (7) in the hole (8) of the side splash guard support (**Fig.8**).

14. Set the fastening anchors (4) to their working position, turn them a quarter turn anti-clockwise, and move them downwards (**Fig.9**).

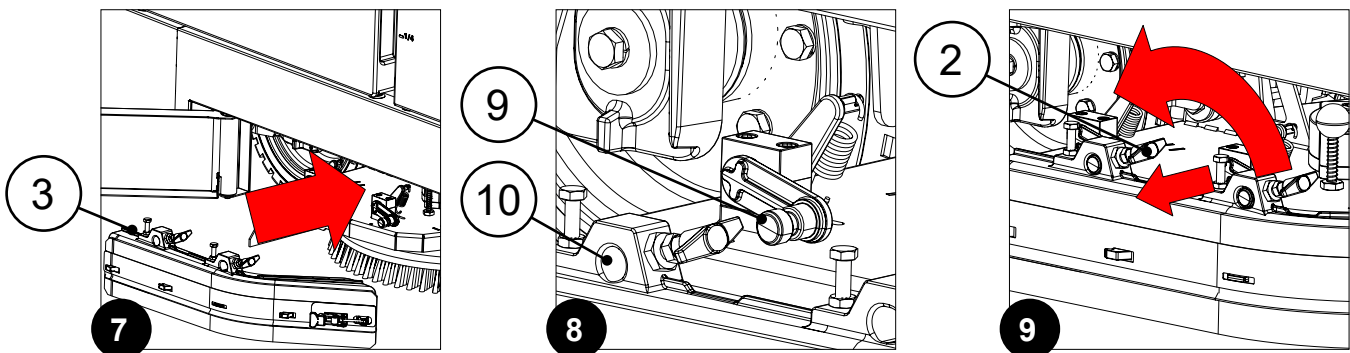

15. Close the left inspection door.

16. Repeat steps thirteen to fifteen for the right-hand splash guard.

i **N.B.:** The side splash guard supports come pre-adjusted. However, if they should need to be adjusted, see [“ADJUSTMENT OF BRUSH HEAD SIDE SPLASH GUARD \(DISCOID SCRUBBING VERSION\)”](#) on page 156.

ASSEMBLING THE ABRASIVE PAD (DISCOID SCRUBBING VERSION)

To mount the abrasive pad on the drive discs on the brush head, do the following:

1. Take the machine to the maintenance area.
2. Activate the "SERVICE" function, see ["SERVICE FUNCTION" on page 86](#).
3. Perform all the operations required to secure the machine. See ["MACHINE SAFETY" on page 35](#).



CAUTION: it is recommended to wear the appropriate PPE (Personal Protective Equipment), suitable for the work to be carried out.

4. Open the left inspection door (1) (**Fig.1**).
5. Set the fastening anchors (2) on the side splash guard support to the service position, move them upwards, and turn them a quarter turn clockwise (**Fig.2**).
6. Extract the left side splash guard support (3) from the brush head (**Fig.3**).

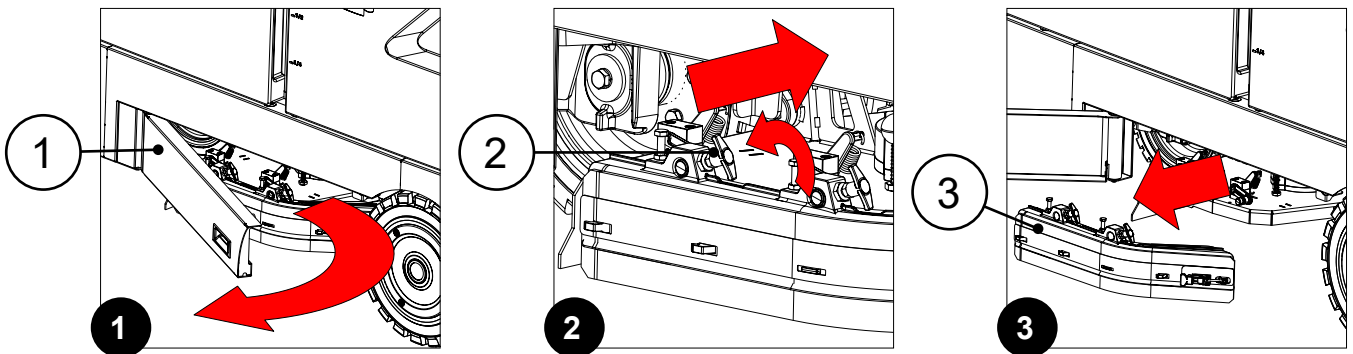

7. Keeping the pin (4) pressed, turn the drive disc (5) clockwise until it is locked in place (**Fig.4**).



N.B.: turn the drive disc quickly and firmly so as to push the button towards the outside of the coupling spring until it releases (**Fig.4**).

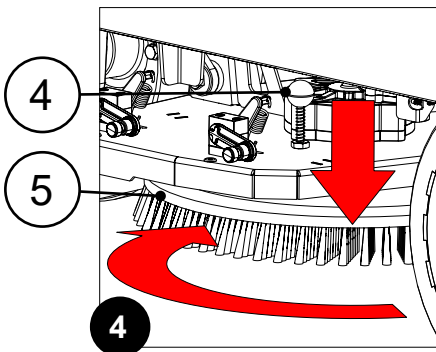

8. With the pad holder removed, insert the abrasive pad you want to use into the bottom of the pad holder.
9. Refit the drive disc in the brush head.
10. Close the left inspection door.
11. Repeat the operation just performed on the right side as well.

ASSEMBLY OF THE SIDE BRUSH HEAD BRUSH OR DRIVE DISCS (DISCOID SCRUBBING VERSION)

To assemble the side brush on the machine, do the following:

1. Take the machine to the maintenance area.
2. Perform all the operations required to secure the machine. See [“MACHINE SAFETY” on page 35](#).

CAUTION: it is recommended to wear the appropriate PPE (Personal Protective Equipment), suitable for the work to be carried out.

3. Stand on the right side of the machine.
4. Insert the brush (1) into the brush holder plate (2) on the side brush head (**Fig.1**).
5. Turn the brush clockwise until the brush is secured onto the brush holder plate (**Fig.2**).

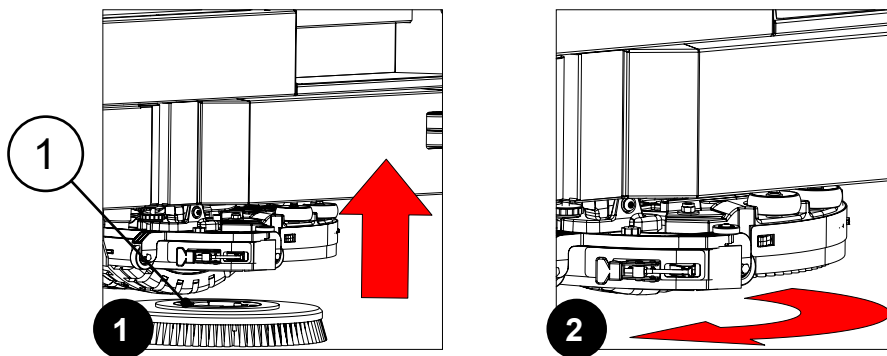

ASSEMBLING THE SIDE BRUSH HEAD ABRASIVE PAD (DISCOID SCRUBBING VERSION)

To mount the abrasive pad on the drive disc of the side brush head, do the following.

1. Take the machine to the maintenance area.
2. Perform all the operations required to secure the machine. See [“MACHINE SAFETY” on page 35](#).

CAUTION: it is recommended to wear the appropriate PPE (Personal Protective Equipment), suitable for the work to be carried out.

3. Stand on the right side of the machine.
4. Moving the brush uncoupling lever (1), rotate the drive disc anti-clockwise until it stops (**Fig.1**).

N.B.: turn the drive disc quickly and firmly so as to push the button towards the outside of the coupling spring until it releases (**Fig.2**).

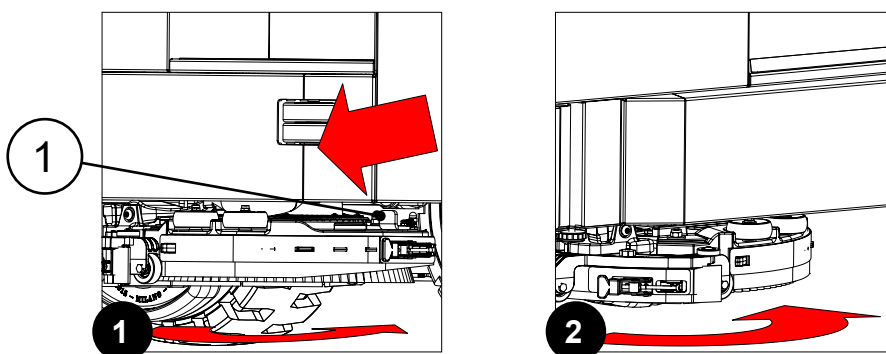

5. With the pad holder removed, insert the abrasive pad you want to use into the bottom of the pad holder.
6. Refit the drive disc in the side brush head.

FITTING OF BRUSHES (CYLINDRICAL SCRUBBING VERSION)

To assemble the brushes on the brush head, proceed as follows:

1. Take the machine to the maintenance area.
2. Activate the "SERVICE" function, see ["SERVICE FUNCTION" on page 86](#).
3. Perform all the operations required to secure the machine. See ["MACHINE SAFETY" on page 35](#).



CAUTION: it is recommended to wear the appropriate PPE (Personal Protective Equipment), suitable for the work to be carried out.

4. Open the left inspection door (1) (**Fig.1**).
5. Set the fastening anchors (2) on the side splash guard support to the service position, move them upwards, and turn them a quarter turn clockwise (**Fig.2**).
6. Remove the left side splash guard (3) from the brush head (**Fig.3**).

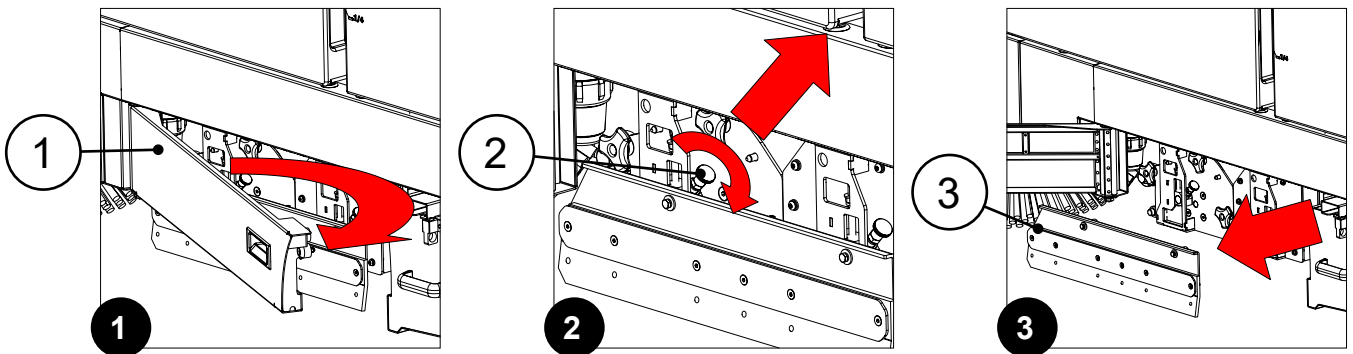

7. Remove the knobs (4) that secure the front brush support (5) (**Fig.4**).
8. Extract the front brush support (5) from the brush head (**Fig.5**).
9. Insert the brush (6) into the tow hook (7) on the brush head body (**Fig.6**).

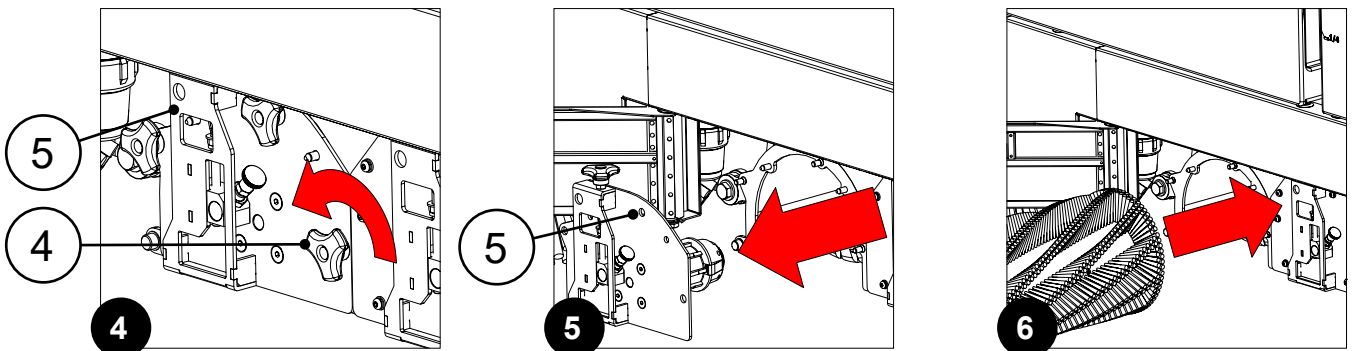

10. Rotate the brush until the fastening hooks (8), present in the tow hook (9) fixed to the idle shaft (10) (**Fig. 7**), correctly enter the slots (11) in the brush (**Fig.8**).
11. Insert the front brush support (5) (**Fig.9**).

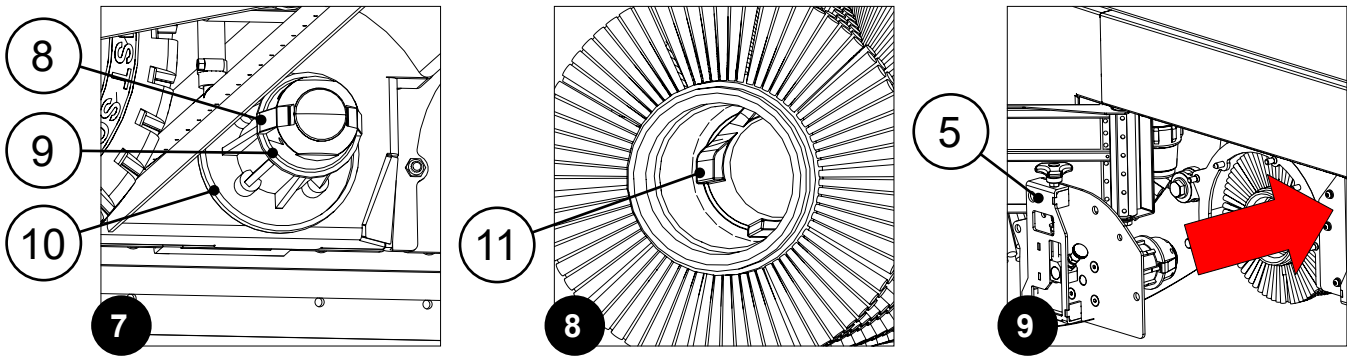

⚠ ATTENTION: pay particular attention that the fastening hooks (12), present in the tow hook (13) of the inspection hatch (5) (Fig. 10), correctly enter the slots (14) in the brush (Fig.11).

⚠ ATTENTION: pay particular attention that the fixing pins (15), present in the brush head body, are correctly positioned in the holes in the front brush support (Fig.12).

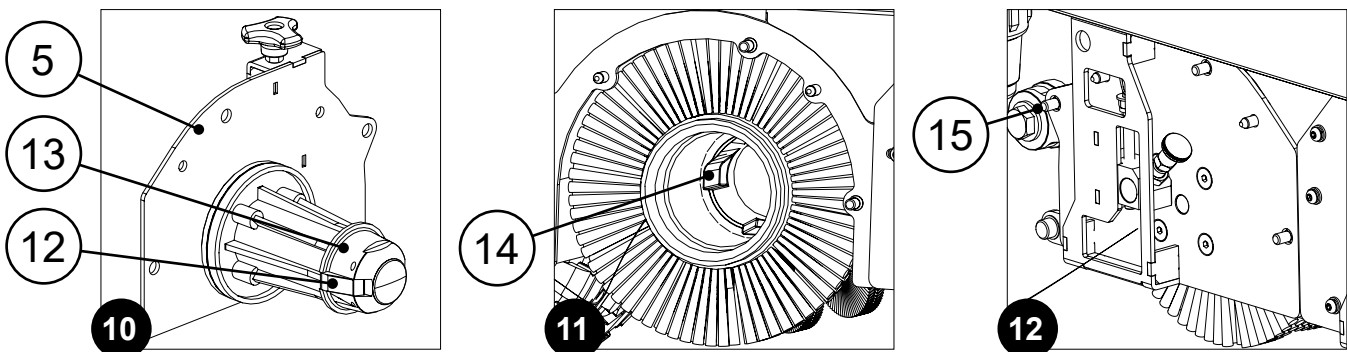

12. Fix the front brush support (5) to the brush head body using the knobs (4) previously removed (Fig.13).

13. Position the left side splash guard (3) to the brush head (Fig.14).

⚠ ATTENTION: pay particular attention that the fixing pins (16), are correctly positioned in the holes (17) in the support (18) (Fig.15).

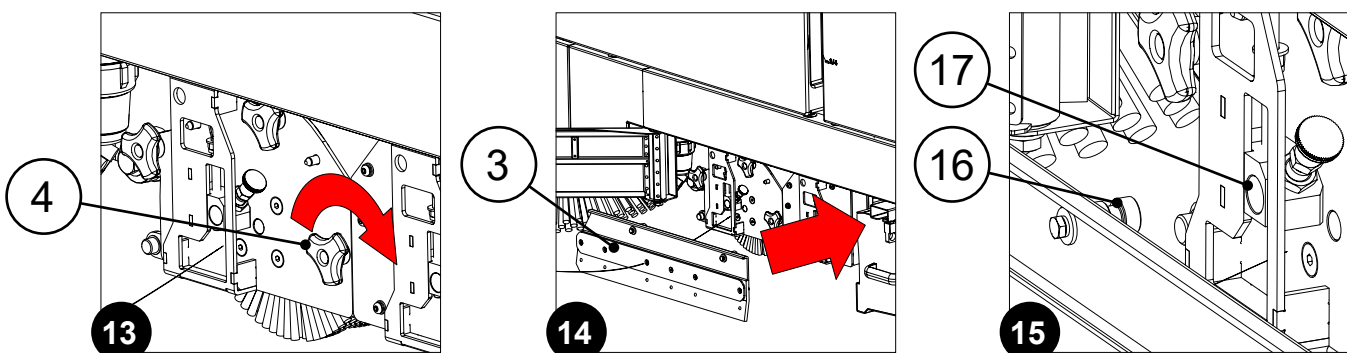

14. Set the fastening anchors (2) to their working position, turn them a quarter turn anti-clockwise, and move them downwards (Fig.16).

15. Close the left inspection door (1) (Fig.17).

16. Repeat the operations just carried out for the right lateral splash guard support as well.

i N.B.: in order to be installed correctly, the brushes must form an X when viewed from above in the forward direction of movement.

i **N.B.:** The side splash guard supports come pre-adjusted. However, if they should need to be adjusted, see [“ADJUSTMENT OF BRUSH HEAD SIDE SPLASH GUARD \(CYLINDRICAL SCRUBBING VERSION\)”](#) on page 157.

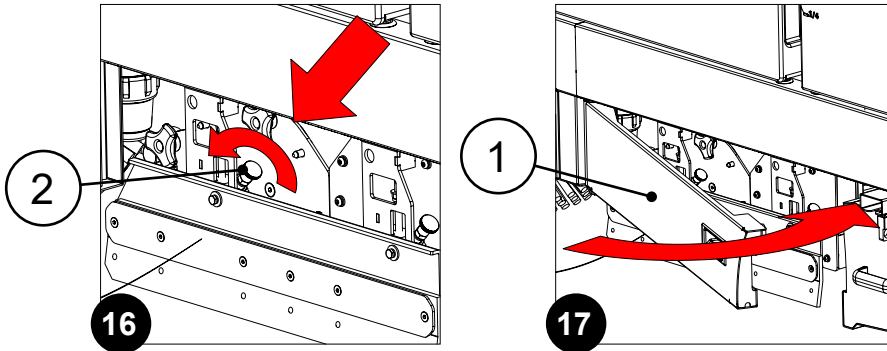

ASSEMBLY OF THE SIDE BRUSHES (CYLINDRICAL - COMBINED SCRUBBING VERSION)

To assemble the brushes on the brush head, proceed as follows:

1. Take the machine to the maintenance area.
2. Activate the "SERVICE" function, see [“SERVICE FUNCTION”](#) on page 86.
3. Perform all the operations required to secure the machine. See [“MACHINE SAFETY”](#) on page 35.



CAUTION: it is recommended to wear the appropriate PPE (Personal Protective Equipment), suitable for the work to be carried out.

4. Stand on the left side of the machine.
5. Remove the knob (1) fixing the side brush to the gear motor by rotating the right brush clockwise and the left brush anti-clockwise (**Fig.1**).
6. Remove the washer (2) holding the side brush in place (**Fig.2**).
7. Insert the side brush, making sure to correctly position the pins (3), present in the brush support, in the holes (4), present in the brush (**Fig.3**).

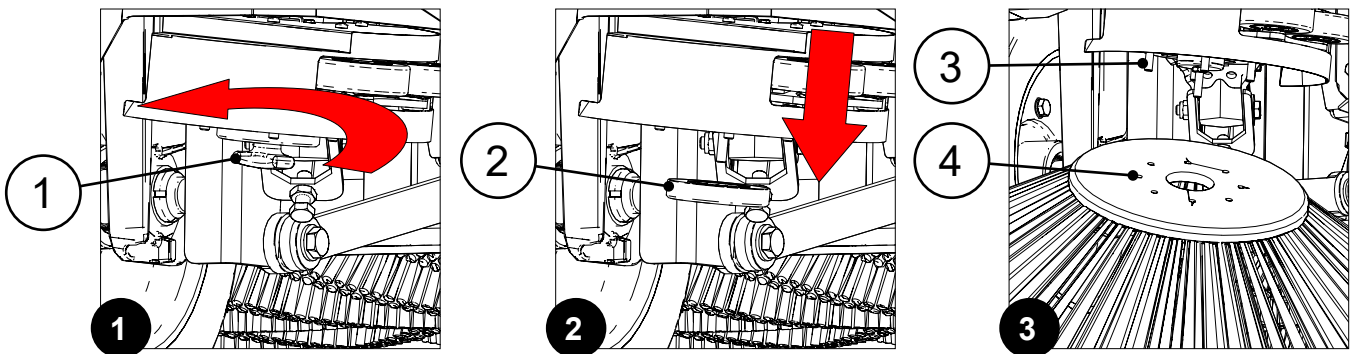

8. Fix the brush to the flange using the knob (1), remembering to put the washer (2) in between the knob and the brush.
9. Once the brush has been fitted, move on to the one on the right.

ASSEMBLY OF BRUSHES (COMBINED VERSION)

To assemble the brushes on the brush head, proceed as follows:

1. Take the machine to the maintenance area.
2. Activate the "SERVICE" function, see ["SERVICE FUNCTION" on page 86](#).
3. Perform all the operations required to secure the machine. See ["MACHINE SAFETY" on page 35](#).

 **CAUTION:** it is recommended to wear the appropriate PPE (Personal Protective Equipment), suitable for the work to be carried out.

4. Open the left inspection door (1) (**Fig.1**).
5. Remove the knobs (2) that secure the front brush support (**Fig.2**).
6. Extract the front brush support (3) from the brush head (**Fig.3**).

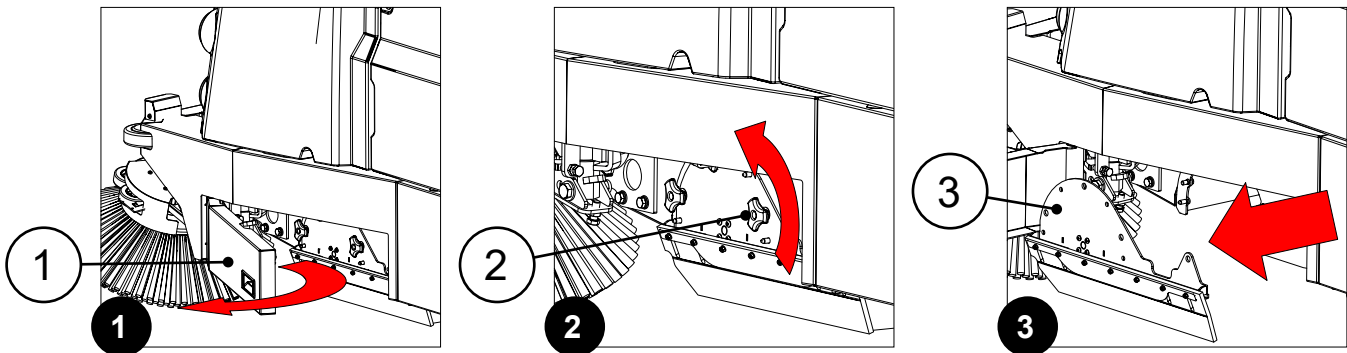

7. Insert the brush into the tow hook on the brush head body (**Fig.4**).
8. Rotate the brush until the fastening hooks (4) present in the tow hook (5) (**Fig. 5**) correctly enter the slots (6) in the brush (**Fig.6**).

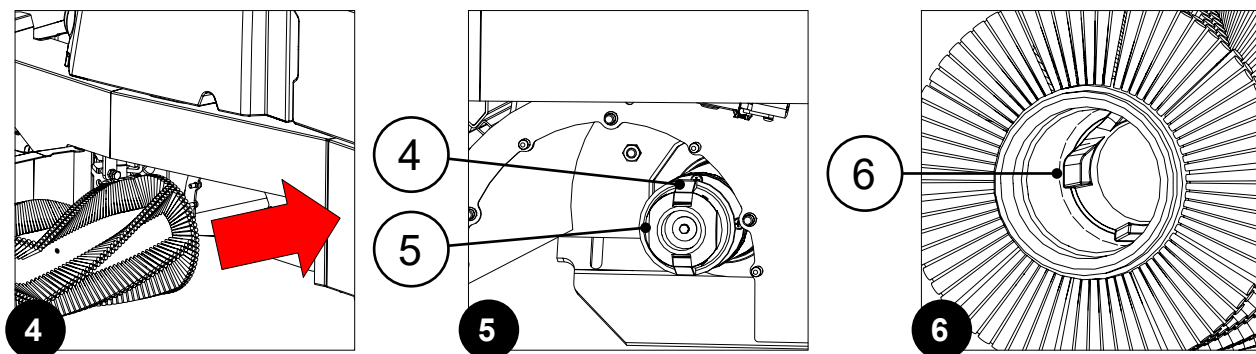

9. Insert the front brush support (3) (**Fig.7**).
10. Rotate the brush until the fastening hooks (7), present in the tow hook (8) fixed to the idle shaft (**Fig. 8**), correctly enter the slots (10) on the brush (**Fig.9**).

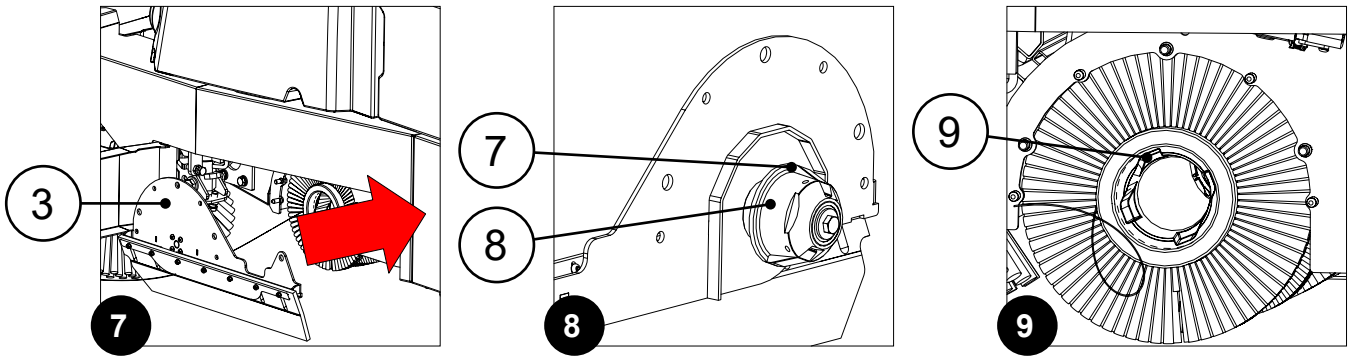

⚠ ATTENTION: pay particular attention that the fixing pins (10), present in the brush head body, are correctly positioned in the holes (11) in the front brush support (**Fig.10**).

11. Fix the front brush support (3) to the brush head body using the knobs (2) previously removed (**Fig.11**).
12. Close the left inspection door (1) (**Fig.12**).
13. Repeat the operations just carried out for the right lateral splash guard support as well.

i N.B.: in order to be installed correctly, the brushes must form an X when viewed from above in the forward direction of movement.

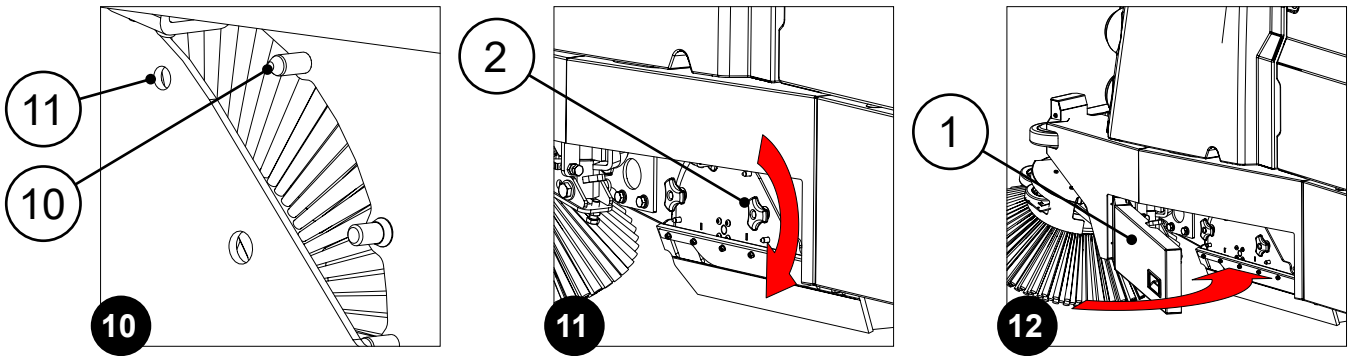

WORK PREPARATION CHECKLIST

Check for any fluid leaks.	If any fluid leaks are encountered, contact your FIMAP service centre of reference, or the centre nearest to you.
Check the fluid level of the brake system.	If alarm indicator 15 appears on the control display, contact your FIMAP service centre of reference, or the centre nearest to you.
Check the horn; the front and rear lights; the safety lights and the alarm (if installed).	If there is a fault, contact your FIMAP service centre of reference, or the centre nearest to you.
Check that the service brakes and steering are functioning properly.	If there is a fault, contact your FIMAP service centre of reference, or the centre nearest to you.
Check that the electric brake is correctly engaged.	If the electric brake off symbol appears on the control display when turning on the machine, see “TRACTION ELECTRIC BRAKE ACTIVATION” on page 41.
Check the tyres to make sure they are not damaged.	If there is a fault, contact your FIMAP service centre of reference, or the centre nearest to you.
Check the charge level of the battery box.	Check the charge level of the battery box on the control display, and recharge it if necessary. See the “RECHARGING THE BATTERY BOX” on page 42.
For machine versions equipped with the standard seat, adjust the driver's seat.	Adjust the driver's seat before starting the work activities. See “ADJUSTMENT OF THE DRIVER'S SEAT (STANDARD SEAT)” on page 44.
For machine versions equipped with the comfort seat, adjust the driver's seat.	Adjust the driver's seat before starting the work activities. See “ADJUSTMENT OF THE DRIVER'S SEAT (COMFORT SEAT)” on page 44.
Check whether the solution tank is full.	If the solution tank is empty, refill it, see “DETERGENT SOLUTION” on page 46.
Check whether the recovery tank is full.	If the recovery tank is full, empty it. See “DRAINING THE RECOVERY TANK” on page 121.
For scrubbing machine versions with cylindrical brushes, check whether the debris hopper in the brush head body is full.	If the debris hopper is full, empty it. See “EMPTYING THE DEBRIS HOPPER (CYLINDRICAL VERSION)” on page 79.
Check the condition of the collection filter tray on the recovery tank.	If the tray is dirty, clean it. See “CLEANING THE COLLECTION FILTER TRAY” on page 119.
Check the condition of the wave protection tray on the recovery tank.	If the tray is dirty, clean it. See “CLEANING THE WAVE PROTECTION TRAY” on page 120.
Check the condition of the water system filter.	If the cartridge in the filter body is dirty, clean it. See “CLEANING THE WATER SYSTEM FILTER” on page 123.
For machine versions equipped with the automatic detergent dosing system, check the condition of the chemical detergent filter.	If the cartridge in the filter body is dirty, clean it. See the “CLEANING THE FILTER ON THE AUTOMATIC CHEMICAL DETERGENT MANAGEMENT SYSTEM (FSS VERSION)” on page 124.
For machine versions equipped with the detergent solution recycling system, check the conditions of the detergent solution recycling system filter in the recovery tank.	If the detergent solution recycling system filter in the recovery tank is dirty, clean it. See “CLEANING THE FILTER ON THE DETERGENT SOLUTION RECYCLING SYSTEM (FLR VERSION)” on page 125.

<p>Check the condition of the side splash guards in the scrubbing head.</p>	<p>If the side splash guards on the brush head are dirty, see “CLEANING OF SIDE BRUSH HEAD SPLASH GUARD (DISCOID SCRUBBING VERSION)” on page 129.</p>
	<p>If the side splash guards on the brush head are worn or damaged, replace them. See “REPLACEMENT OF BRUSH HEAD SIDE SPLASH GUARD (DISCOID SCRUBBING VERSION)” on page 143.</p>
	<p>If the side splash guards on the brush head are dirty, see “CLEANING OF BRUSH HEAD SIDE SPLASH GUARD (CYLINDRICAL SCRUBBING VERSION)” on page 132.</p>
	<p>If the side splash guards on the brush head are worn or damaged, replace them. See “REPLACEMENT OF BRUSH HEAD SIDE SPLASH GUARD (CYLINDRICAL SCRUBBING VERSION)” on page 148.</p>
<p>Check the condition of the brushes in the scrubbing head.</p>	<p>If the brushes in the brush head are dirty, clean them, see “CLEANING OF BRUSH HEAD DRIVE BRUSH - DISC (DISCOID SCRUBBING VERSIONS)” on page 126.</p>
	<p>If the brushes in the brush head are worn or damaged, replace them. See “REPLACEMENT OF BRUSH HEAD DRIVE BRUSHES OR DISCS (DISCOID SCRUBBING VERSION)” on page 141.</p>
	<p>If the brushes in the brush head are dirty, clean them, see “CLEANING OF BRUSH HEAD BRUSH (CYLINDRICAL SCRUBBING VERSIONS)” on page 131.</p>
	<p>If the brushes in the brush head are worn or damaged, replace them. See “REPLACING THE BRUSH HEAD BRUSHES (CYLINDRICAL SCRUBBING VERSION)” on page 148.</p>
<p>Check the condition of the brushes in the combined machine version.</p>	<p>If the brushes in the brush head are dirty, clean them. See “CLEANING THE BRUSH HEAD BRUSHES (COMBINED VERSION)” on page 135.</p>
	<p>If the brushes in the brush head are worn or damaged, replace them. See “REPLACING THE SWEEPING BRUSH HEAD BRUSHES (COMBINED VERSION)” on page 151.</p>
<p>For machine versions equipped with side scrubbing brush, check the condition of the splash guard.</p>	<p>If the splash guard is dirty, clean it. See “CLEANING OF SIDE BRUSH HEAD SPLASH GUARD (DISCOID SCRUBBING VERSION)” on page 129.</p>
	<p>If the side splash guards on the brush head are worn or damaged, replace them. See “REPLACEMENT OF BRUSH HEAD SIDE SPLASH GUARD (DISCOID SCRUBBING VERSION)” on page 143.</p>
<p>For machine versions equipped with the side brush, check the condition of the brush on the side brush head.</p>	<p>If the brush in the side brush head is dirty, clean it. See “CLEANING OF SIDE BRUSH HEAD DRIVE BRUSH - DISC (DISCOID SCRUBBING VERSION)” on page 128.</p>
	<p>If the brush in the side scrubbing brush head is worn or damaged, replace it. See “REPLACEMENT OF SIDE BRUSH HEAD DRIVE BRUSH OR DISCS (DISCOID SCRUBBING VERSION)” on page 144.</p>

<p>For machine versions with sweeping side brushes, check the condition of the brushes in the side brush heads.</p>	<p>If the brush in the side brush head is dirty, clean it. See “CLEANING THE SIDE BRUSH (CYLINDRICAL - COMBINED SCRUBBING VERSION)” on page 133.</p> <p>If the brush in the side brush head is worn or damaged, replace it. See “REPLACEMENT OF THE SIDE BRUSH (CYLINDRICAL-COMBINED SCRUBBING VERSION)” on page 150.</p>
<p>Check the condition of the squeegee.</p>	<p>If the squeegee is dirty, clean it, see “CLEANING THE SQUEEGEE” on page 116.</p>
<p>Check the state of wear of the rubber blades in the squeegee.</p>	<p>If the wear of the squeegee rubber blades is unsuitable for the job to be carried out, replace them. See “REPLACING THE SQUEEGEE RUBBER BLADES” on page 146.</p>
<p>For machine versions equipped with the lateral scrubbing brush head, check the condition of the lateral squeegee body.</p>	<p>If the side squeegee is dirty, clean it, see “CLEANING OF SIDE BRUSH HEAD SQUEEGEE (DISCOID SCRUBBING VERSION)” on page 130.</p>
<p>For machine versions equipped with the lateral scrubbing brush head, check the wear status of the lateral squeegee body's rubber blades.</p>	<p>If the wear of the squeegee rubber blades is unsuitable for the job to be carried out, replace them. See “REPLACEMENT OF SIDE BRUSH HEAD SQUEEGEE RUBBER BLADES (DISCOID SCRUBBING VERSION)” on page 145.</p>
<p>Check the condition of the squeegee vacuum tube.</p>	<p>If the squeegee vacuum pipe is dirty, clean it, see “CLEANING THE SQUEEGEE VACUUM HOSE” on page 117.</p>
<p>For scrubbing machine versions with cylindrical brushes, check the state of the debris hopper suction filter.</p>	<p>If the collection filter is blocked or dirty, clean it. See “CLEANING THE DEBRIS HOPPER (CYLINDRICAL SCRUBBING VERSION)” on page 132.</p>
<p>Check that the gasket on the recovery tank's lid is not damaged or worn.</p>	<p>If the gasket is damaged, contact the FIMAP service centre to have it replaced.</p>
<p>For machine versions with the continuous detergent solution recycling system, check the dirty detergent solution filters inside the recovery tank.</p>	<p>If the dirty detergent solution filters in the recovery tank are dirty, clean them. See “CLEANING THE FILTER ON THE DETERGENT SOLUTION RECYCLING SYSTEM (FLR VERSION)” on page 125.</p>

WORKING PROGRAMS

Six types of programs are already stored in the function board memory, which can be used to facilitate machine use by the operator.

In the working programs, the performance levels of the parameters:





- machine forward speed;
- pressure exerted on the machine brush head;
- detergent solution level in the machine water system;
- machine vacuum system performance level;

are all preset and cannot be changed.

i **N.B.:** for machine versions with the automatic detergent dosing system, only the parameter regarding the percentage of chemical product in the detergent solution can be modified, see [“MODIFICA QUANTITÀ DI CHIMICO NEL SISTEMA DOSAGGIO AUTOMATICO DETERGENTE \(SETTAGGI - DETERGENTE\)”](#) on page 19 or [“MODIFICARE IL PARAMETRO PERCENT. CHEMICAL \(PUMP - CHEMICAL\)”](#) on page 50 of the “OPERATOR INTERFACE CONFIGURATION MANUAL” which can be downloaded from the site www.fimap.com

i **N.B.:** the working programs can be selected quickly using the membrane push-button panel in the control point, see [“MEMBRANE PUSH-BUTTON PANEL FOR ACTIVATING WORKING PROGRAMS”](#) on page 30.

The machine can be used with the following working programs:

	<p>ECO MODE: for light maintenance cleaning tasks, using fewer resources and operating at a low noise level, see “ECO MODE WORKING PROGRAM” on page 63).</p>
	<p>COMFORT MODE: for routine, non-aggressive cleaning for everyday cleaning operations, see “COMFORT MODE WORKING PROGRAM” on page 64.</p>
	<p>DYNAMIC MODE: for ordinary cleaning that aims to achieve greater productivity, this permits cleaning operations to be carried out quickly, see “DYNAMIC MODE WORKING PROGRAM” on page 65.</p>
	<p>HEAVY MODE: for operations where maximum scrubbing power is required to clean particularly dirty environments, see “HEAVY MODE WORKING PROGRAM” on page 66.</p>
	<p>PROGRAM ZONE: for recurring interventions at work sites, there are four working programs stored in the machine's memory that can be easily selected in order to help the operator carry out the intervention correctly, see “ZONE MODE WORKING PROGRAM” on page 67).</p>
	<p>MANUAL MODE: the operator freely evaluates and chooses the parameters based on the cleaning requirements that arise during the course of the operation, see “MANUAL MODE WORKING PROGRAM” on page 68).</p>
	<p>POWER MODE: for short working operations (max. 120 seconds) where maximum scrubbing power is required to clean particularly dirty environments, see “POWER MODE WORKING PROGRAM” on page 69.</p>

ECO MODE WORKING PROGRAM

The ECO MODE working program can be used for light maintenance work.

The ECO MODE program is a program which guarantees the best possible performance in terms of consumption and cleaning.

The ECO MODE working program can be activated by pressing the button (1) on the membrane push-button panel (Fig.1).

- i** **N.B.:** as soon as the button (1) is pressed, the control display (Fig.2) shows the screen dedicated to the ECO MODE working program and the program name is displayed in the circular symbol (2).
- i** **N.B.:** to deactivate the ECO MODE program, press one of the four buttons related to the machine performance levels on the membrane push-button panel, see [“MEMBRANE PUSH-BUTTON PANEL FOR ACTIVATING WORKING PROGRAMS” on page 30.](#)
- i** **N.B.:** by selecting the ECO MODE working program, the values related to the machine performance levels (speed, force exercised on the brushes, vacuum system performance, detergent solution flow) are changed automatically.

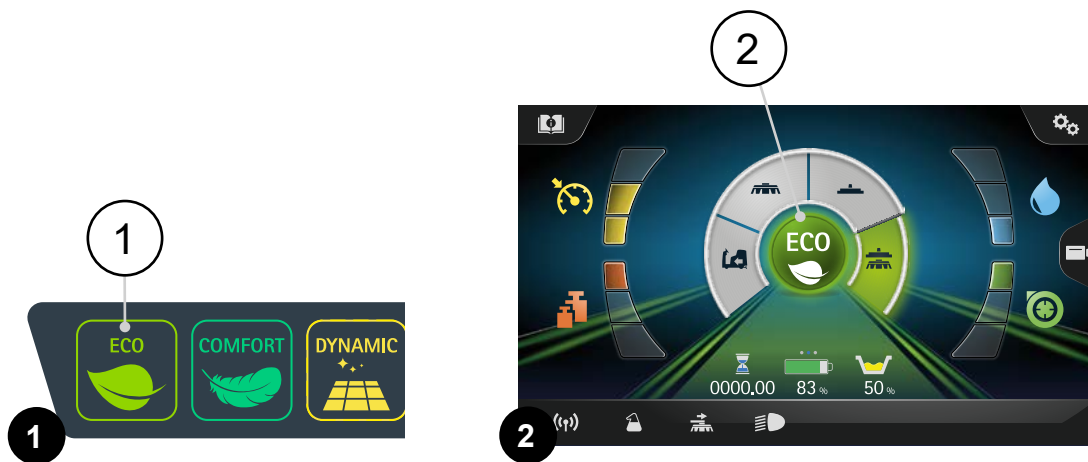

The parameters pre-set on a scale of 1 to 3 are as follows:

Speed	Brush	Vacuuming	Detergent Solution
2	1	1	1

COMFORT MODE WORKING PROGRAM

The COMFORT MODE working program can be used for ordinary, non-aggressive cleaning suitable for daily use.

The COMFORT MODE working program can be activated by pressing the button (1) on the membrane push-button panel (Fig.1).

- i** **N.B.:** as soon as the button (1) is pressed, the control display (Fig.2) shows the screen dedicated to the COMFORT MODE working program and the program name is displayed in the circular symbol (2).
- i** **N.B.:** to deactivate the COMFORT MODE program, press one of the four buttons related to the machine performance levels on the membrane push-button panel, see [“MEMBRANE PUSH-BUTTON PANEL FOR ACTIVATING WORKING PROGRAMS” on page 30.](#)
- i** **N.B.:** to deactivate the COMFORT MODE program, press one of the four icons related to the machine performance levels on the control display, see [“CONTROL DISPLAY” on page 31.](#)
- i** **N.B.:** by selecting the COMFORT MODE working program, the values related to the machine performance levels (speed, force exercised on the brushes, vacuum system performance, detergent solution flow) are changed automatically.

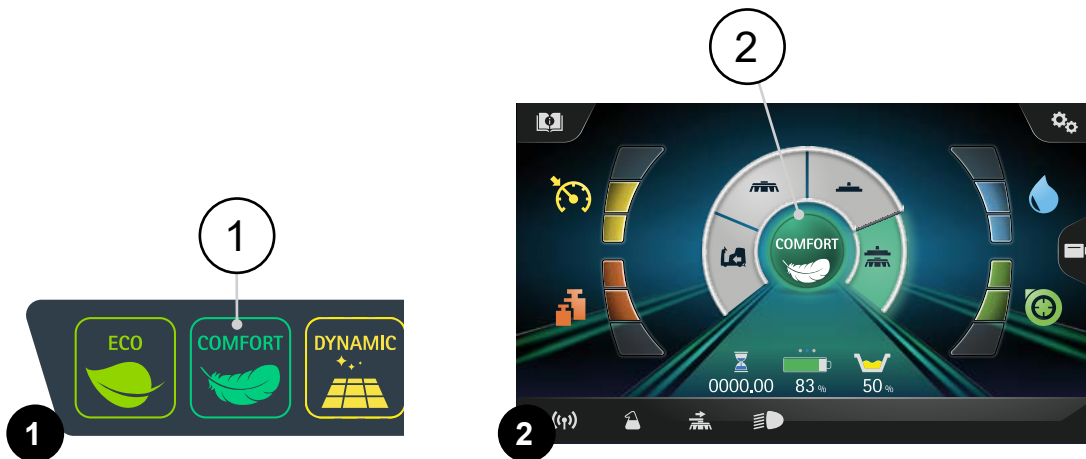

The parameters pre-set on a scale of 1 to 3 are as follows:

Speed	Brush	Vacuuming	Detergent Solution
2	2	2	2

DYNAMIC MODE WORKING PROGRAM

The DYNAMIC MODE working program can be used for ordinary cleaning that aims to achieve greater productivity, it permits performing daily cleaning operations quickly.

The DYNAMIC MODE working program can be activated by pressing the button (1) on the membrane push-button panel (Fig.1).

- i** **N.B.:** as soon as the button (1) is pressed, the control display (Fig.2) shows the screen dedicated to the DYNAMIC MODE working program and the program name is displayed in the circular symbol (2).
- i** **N.B.:** to deactivate the DYNAMIC MODE program, press one of the four buttons related to the machine performance levels on the membrane push-button panel, see [“MEMBRANE PUSH-BUTTON PANEL FOR ACTIVATING WORKING PROGRAMS” on page 30.](#)
- i** **N.B.:** to deactivate the DYNAMIC MODE program, press one of the four icons related to the machine performance levels on the control display, see [“CONTROL DISPLAY” on page 31.](#)
- i** **N.B.:** by selecting the DYNAMIC MODE working program, the values related to the machine performance levels (speed, force exercised on the brushes, vacuum system performance, detergent solution flow) are changed automatically.

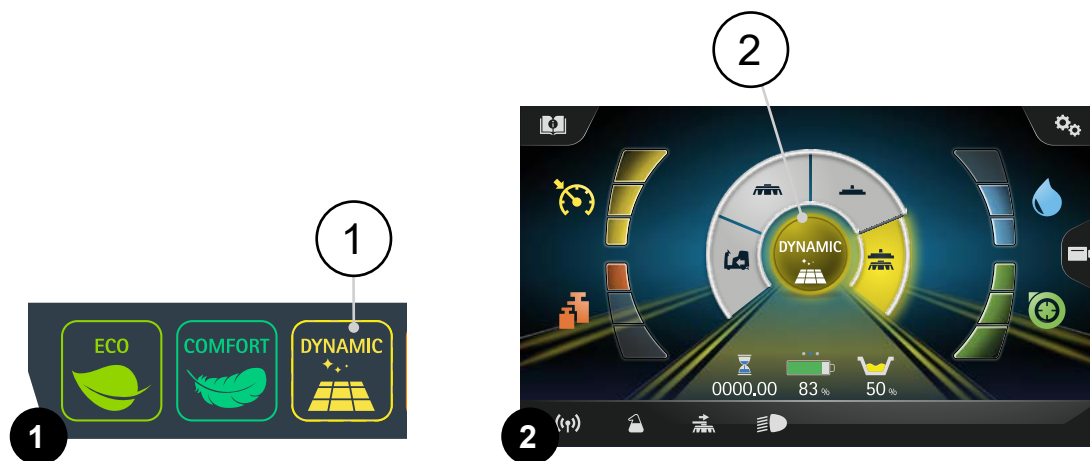

The parameters pre-set on a scale of 1 to 3 are as follows:

Speed	Brush	Vacuuming	Detergent Solution
3	1	3	2

HEAVY MODE WORKING PROGRAM

The HEAVY MODE working program can be used for operations requiring considerable scrubbing power and for cleaning particularly dirty environments .

The HEAVY MODE working program can be activated by pressing the button (1) on the membrane push-button panel (**Fig.1**).

- i** **N.B.:** as soon as the button (1) is pressed, the control display (**Fig.2**) shows the **screen** dedicated to the HEAVY MODE working program and the program name is displayed in the circular symbol (2).
- i** **N.B.:** to deactivate the HEAVY MODE program, press one of the four buttons related to the machine performance levels on the membrane push-button panel, see [“MEMBRANE PUSH-BUTTON PANEL FOR ACTIVATING WORKING PROGRAMS” on page 30.](#)
- i** **N.B.:** to deactivate the HEAVY MODE program, press one of the four icons related to the machine performance levels on the control display, see [“CONTROL DISPLAY” on page 31.](#)
- i** **N.B.:** by selecting the POWER working program, the values related to the machine performance levels (speed, force exercised on the brushes, vacuum system performance, detergent solution flow) are changed automatically.



The parameters pre-set on a scale of 1 to 3 are as follows:

Speed	Brush	Vacuuming	Detergent Solution
2	3	3	3

ZONE MODE WORKING PROGRAM

The ZONE MODE working program can be used to help the operator carry out the intervention correctly .

To activate the ZONE MODE working program, proceed as follows:

1. Press the button (1) on the membrane push-button panel (**Fig.1**).
2. Select the working zone to be loaded (**Fig.2**), press "OFFICE", for example, on the control display (2).

i **N.B.:** as soon as the button (1) is pressed, the control display (**Fig.2**) the screen dedicated to the selection of the previously selected work zone appears.

i **N.B.:** as soon as the working zone is selected, the control display (**Fig.3**) shows the screen dedicated to the ZONE MODE working program and the program name is displayed in the circular symbol (3), whereas the text indicator shows the name of the selected program (4).

i **N.B.:** to deactivate the ZONE MODE program, select another working program on the membrane push-button panel, see "[MEMBRANE PUSH-BUTTON PANEL FOR ACTIVATING WORKING PROGRAMS](#)" on [page 30](#).

i **N.B.:** to deactivate the HEAVY MODE program, press one of the four icons related to the machine performance levels on the control display, see "[CONTROL DISPLAY](#)" on [page 31](#).

i **N.B.:** by selecting the working zone to be used, the values related to the machine performance levels (speed, force exercised on the brushes, vacuum system performance, detergent solution flow) are changed automatically.

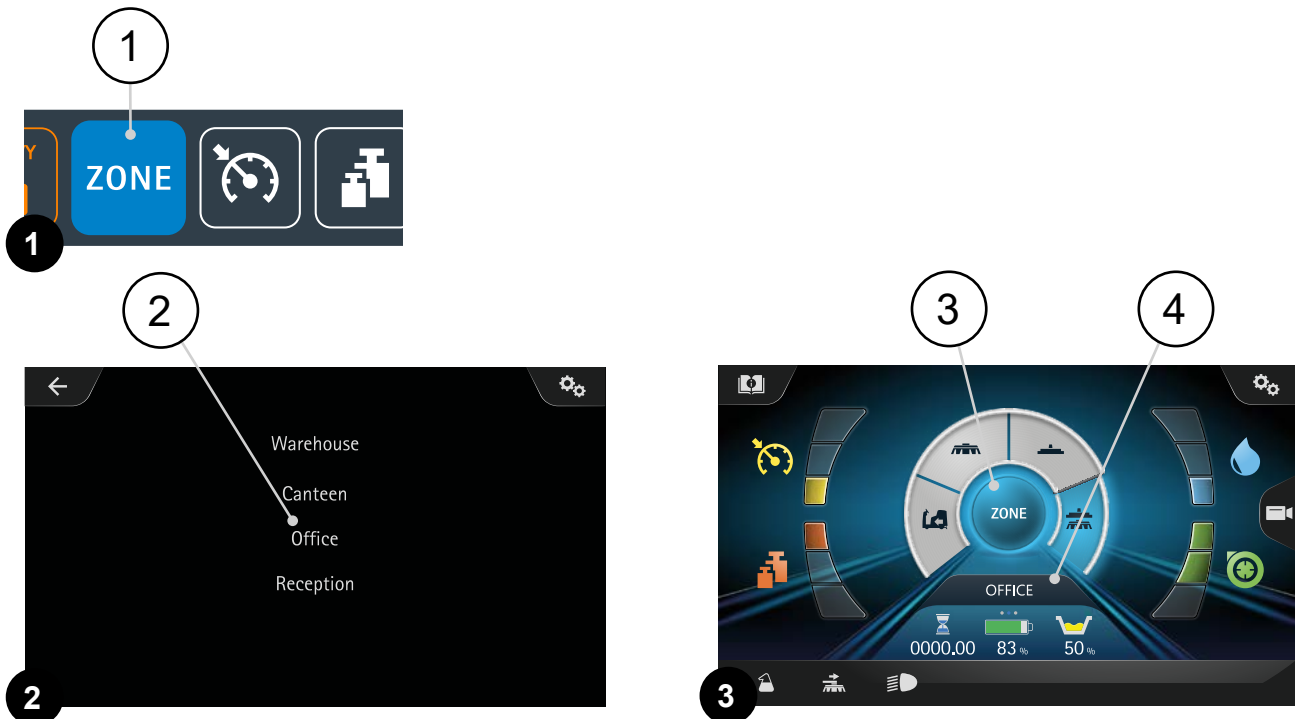





MANUAL MODE WORKING PROGRAM

The MANUAL MODE program is a program where it is the operator who freely evaluates and chooses the parameters based on the cleaning requirements that arise during the course of the operation.





There are two ways to switch to the ZONE MODE working program while working:

1. By pressing the membrane push-button panel (**Fig.1**), pressing one of the four buttons:

	Button for adjusting the forward speed performance level, see “REGULATING THE FORWARD SPEED” on page 83.
	Brush head pressure performance level adjustment button, see “ADJUSTING THE PRESSURE EXERTED ON THE BRUSH HEAD” on page 82.
	Button for adjusting the detergent solution performance level, see “ADJUSTMENT OF THE DETERGENT SOLUTION FLOW” on page 84.
	Vacuum system performance level adjustment button, see “VACUUM SYSTEM PERFORMANCE ADJUSTMENT (SCRUBBING VERSION)” on page 85.

i **N.B.:** as soon as the one of the four buttons indicated above is pressed, the control display (**Fig.2**) shows the screen dedicated to the MANUAL MODE working program and the program name is displayed in the circular symbol (2).

2. Via the control display (**Fig.2**), by pressing one of the four icons:

	Icon for adjusting the forward speed performance level, see “REGULATING THE FORWARD SPEED” on page 83.
	Brush head pressure performance level adjustment icon, see “ADJUSTING THE PRESSURE EXERTED ON THE BRUSH HEAD” on page 82.
	Icon for adjusting the detergent solution performance level, see “ADJUSTMENT OF THE DETERGENT SOLUTION FLOW” on page 84.
	Vacuum system performance level adjustment icon, see “VACUUM SYSTEM PERFORMANCE ADJUSTMENT (SCRUBBING VERSION)” on page 85.

i **N.B.:** as soon as the one of the four buttons indicated above is pressed, the control display (**Fig.2**) shows the screen dedicated to the MANUAL MODE working program and the program name is displayed in the circular symbol (2).

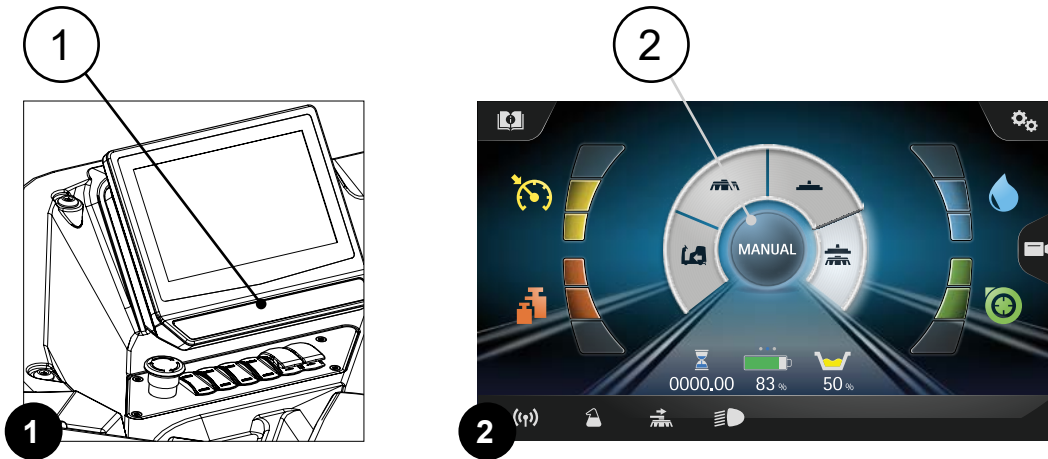

POWER MODE WORKING PROGRAM

The POWER MODE working program can be used if small areas with stubborn dirt are found during an intervention, therefore it is useful to temporarily leave the configuration that is being used in order to use maximum scrubbing force to remove the localised dirt.

The POWER MODE working program can be activated by moving the lever (1) underneath the steering wheel.

- i** **N.B.:** The POWER MODE working program remains active for 120 seconds. To deactivate it wait until the end of the 120 seconds.
- i** **N.B.:** as soon as the level activates on the control display (**Fig.2**) shows the screen dedicated to the POWER MODE working program and the program name is displayed in the circular symbol (2).
- i** **N.B.:** the centre of the screen (**Fig.2**) displays a graphic symbol (4) and a numerical value (3). They display a countdown, at the end of which the screen returns to the work screen previously used and the pressure exerted on the brush head returns to the standard pressure.
- i** **N.B.:** by selecting the POWER working program, the work parameters (speed, force exercised on the brushes, vacuum motor performance, detergent solution flow) are changed automatically.

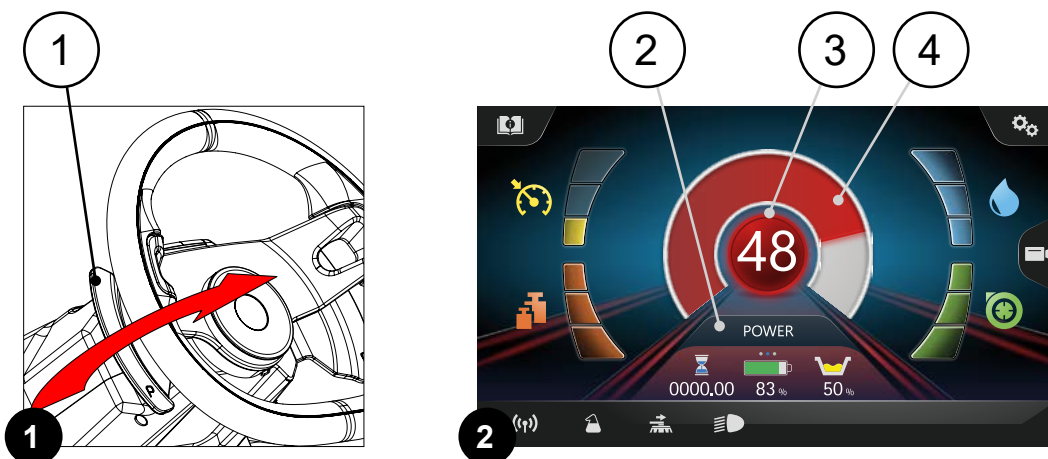

The parameters pre-set on a scale of 1 to 3 are as follows:

Speed	Brush	Vacuuming	Detergent Solution
1	3	3	3

WORKING MODE

DS SELECTOR (DRIVE SELECT)

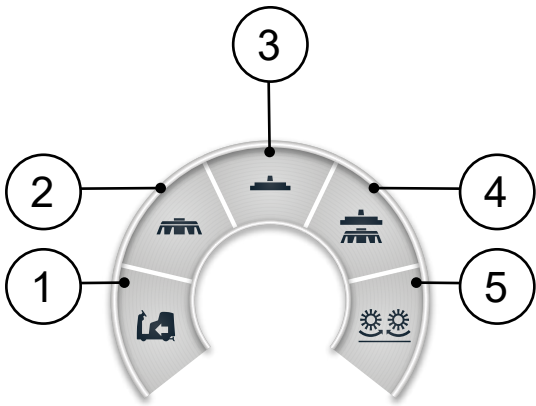

The DS selector can be used to select one of the following working modes:

1. Transfer: to transfer the machine from the place of work to the maintenance site.
2. Pre-scrub: to carry out a pre-wash on floors where dirt is most persistent.
3. Drying: to dry a previously washed floor.
4. Scrubbing: to clean the floor at the same time as drying it.
5. Sweeping: to sweep the floor at the same time as washing it.

i **N.B.:** to select one of the working modes, simply press one of the icons on the DS selector switch; the selector switch is located in the centre of the control screen.

i **N.B.:** switching from one working mode to another does not change the working program used up to that moment



ATTENTION: The drying only operation should only be carried out if the machine was used beforehand to carry out a prescrubbing operation.



ATTENTION: if changing from one working mode with scrubbing (pre-scrubbing or scrubbing-drying) to the transfer working mode, the machine activates the smart drying function, see **“SMART DRYING MODE”** on page 92.

STARTING WORK

By way of example, let's say we want to use the scrubbing machine working mode (i.e. scrubbing and drying the floor) with the ECO MODE working program. To begin the work activities, do the following:

1. Carry out all the checks listed in the ["WORK PREPARATION CHECKLIST"](#) on page 59.
2. Sit on the driver's seat.
3. Insert the key (1) into the slot (2) on the right side of the column (**Fig.1**).
4. Turn on the machine and turn the key (1) a quarter turn clockwise (**Fig.2**).

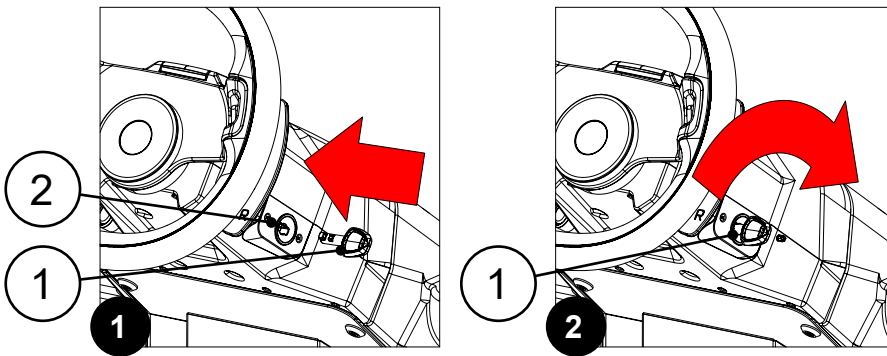

5. When turning on the display, machine animation and then the machine logo is loaded, after a few seconds the working screen appears automatically.



i **N.B.:** a few seconds after the machine is turned on, the pop-up that is shown here on the side may appear on the control display if the FFM system is working; this will suggest that you use a working program optimised to meet the requirements of the work to be carried out, and to suit the environment in which you are about to work. On selecting "CONFIRM", the ZONE MODE working program will automatically activate; see ["ZONE MODE WORKING PROGRAM"](#) on page 67.

i **N.B.:** from the settings menu, it is possible to enable the access PIN code request; if it is active, after the logo screen, you will be taken to the login screen: to continue, you must enter the unlock code number, see ["ATTIVAZIONE O DISATTIVAZIONE PASSWORD DI LIVELLO PIN \(GENERAL - ACCESS MODE\)"](#) on page 33 of the "OPERATOR INTERFACE CONFIGURATION MANUAL" which can be downloaded from the site www.fimap.com

i **N.B.:** the machine can be used when entering the correct PIN code, if an incorrect PIN code is entered the machine cannot be used.

i **N.B.:** after the machine logo screen, the main screen appears (**Fig.3**), which shows the machine performance levels and the activation buttons for the optional functions, see ["CONTROL DISPLAY"](#) on page 31.



6. Activate the “SCRUBBING-DRYING” working mode; on the DS selector, press the button (3) (**Fig.3**).
 - i** **N.B.:** after pressing the scrubbing machine (3) button on the main screen, the screen **Fig.4** appears.
 - i** **N.B.:** by selecting the ECO MODE working program, the pre-set performance levels are automatically loaded, based on those selected on the function board parameters list.

7. If the machine has an automatic detergent dosing system (FSS), or the continuous dosing system recycling system (FLR), press the button (4) on the main screen (**Fig.4**).
 - i** **N.B.:** the FSS function is active when the symbol (4) is green, see [“FSS - AUTOMATIC DETERGENT DOSING SYSTEM” on page 107.](#)
 - i** **N.B.:** the FLR function is active when the symbol (4) is green, see [“FLR - CONTINUOUS RECYCLING SYSTEM” on page 106.](#)

8. If the work is performed in poorly illuminated areas, turn on the working headlights by pressing the button (5) on the main screen (**Fig.4**).
 - i** **N.B.:** the working headlights function is active when the symbol (5) is green, see [“WORKING HEADLIGHTS” on page 92.](#)

9. If the machine has a side brush, press the button (6) on the main screen (**Fig.4**).
 - i** **N.B.:** the side brush is active when the symbol (6) is green, see [“SIDE BRUSH \(DISCOID SCRUBBING VERSIONS\)” on page 104](#) or [“SIDE BRUSH \(CYLINDRICAL SCRUBBING VERSION\)” on page 105.](#)

10. Press the drive pedal (7) (**Fig.5**) to begin moving the machine.
 - i** **N.B.:** as soon as the brush head and squeegee pedal (7) is pressed, the brush head and squeegee are automatically moved to the working position.
 - i** **N.B.:** the brush motors; the solenoid valve, and the detergent solution pump only begin functioning once the brush head is in its working position.
 - i** **N.B.:** the suction motors are only activated once the squeegee is in its working position.

- i** **N.B.:** if the pedal (7) is released while working, after a few seconds, both the brush head and the squeegee are automatically moved to the intermediate rest position. During the squeegee re-ascent phase, the suction motors remain on in order to ensure that they vacuum up the solution present inside them.
 - i** **N.B.:** to change the reset delay time of the crankcase control actuator, contact a FIMAP service center or see [“MODIFICARE IL PARAMETRO RESET DELAY \(BRUSH - BRUSH MOT\)” on page 40](#) of the “OPERATOR INTERFACE CONFIGURATION MANUAL” which can be downloaded from the site www.fimap.com
 - i** **N.B.:** To change the reset delay time for the vacuum motors, contact a FIMAP service centre.
 - i** **N.B.:** to change the reset delay time for the squeegee control actuator, contact a FIMAP service centre or see [“MODIFICARE IL PARAMETRO RESET DELAY \(Act. After Stop Traction \(Vac. Motor\)\) \(VACUUM - VAC. MOTOR\)” on page 53](#) of the "OPERATOR INTERFACE CONFIGURATION MANUAL", which can be downloaded from the site www.fimap.com
11. The machine will now begin operating at maximum efficiency until the detergent solution is finished or the battery box runs flat.
- i** **N.B.:** during the first few meters of work, check that the quantity of solution dispensed is sufficient to wet the floor. If not, adjust the detergent solution flow, see [“ADJUSTMENT OF THE DETERGENT SOLUTION FLOW” on page 84](#).
 - i** **N.B.:** during the first few meters of work, check that the squeegee dries the floor properly. If not, adjust it. See [“ADJUSTING THE SQUEEGEE RUBBER BLADES” on page 153](#).
 - i** **N.B.:** during the first few meters of work, check that the two side splash guards in the brush head are correctly directing the detergent solution on the floor towards the squeegee; if this is not the case, adjust these. See [“ADJUSTMENT OF BRUSH HEAD SIDE SPLASH GUARD \(DISCOID SCRUBBING VERSION\)” on page 156](#) or [“ADJUSTMENT OF BRUSH HEAD SIDE SPLASH GUARD \(CYLINDRICAL SCRUBBING VERSION\)” on page 157](#).
 - i** **N.B.:** pick up any large pieces of waste before performing the cleaning operations; pick up wire, tape, string, large pieces of wood, or any other types of refuse that could wrap around the brushes or become entangled.
 - i** **N.B.:** drive the machine along the most linear path possible. Avoid hitting any obstacles and scratching the sides of the machine. Overlap the working widths by several centimetres.
 - i** **N.B.:** avoid turning the steering wheel too sharply while the machine is in motion. The machine reacts quickly to the steering wheel's movements.
 - i** **N.B.:** adjust the machine speed, the brush pressure and the flow of the solution based on the type of cleaning to be carried out.
 - i** **N.B.:** The machine's service brake pedal (8), which is used to stop the machine when required (**Fig.6**), is located to the right of the footboard.
 - i** **N.B.:** when the service brake pedal (8) is pressed, the red rear lights become brighter to indicate that the service brake pedal has been pressed.
 - i** **N.B.:** the machine has an encoder to assist with braking, as well as a mechanical brake. If the machine is moving and the accelerator pedal (7) is released, the machine brakes, decelerating gently, until it stops the encoder. Only when the encoder has stopped is the electric brake engaged. If the machine is moving and the brake pedal (8) (**Fig.6**) is pressed, the machine brakes with the braking force applied by the mechanical system. Only when the encoder has stopped is the electric brake engaged.

i **N.B.:** upon request, the machine is equipped with an anti-collision system which, upon detection of obstacles or other vehicles, will perform a controlled emergency braking, see [“ANTI-COLLISION SYSTEM” on page 91.](#)

! **ATTENTION:** when the alarm symbol (11) appears on the main screen (**Fig.4**) in addition to the pop-up window (**Fig.7**), this means that the level of oil in the braking system is low, stop the machine and contact a FIMAP service centre.

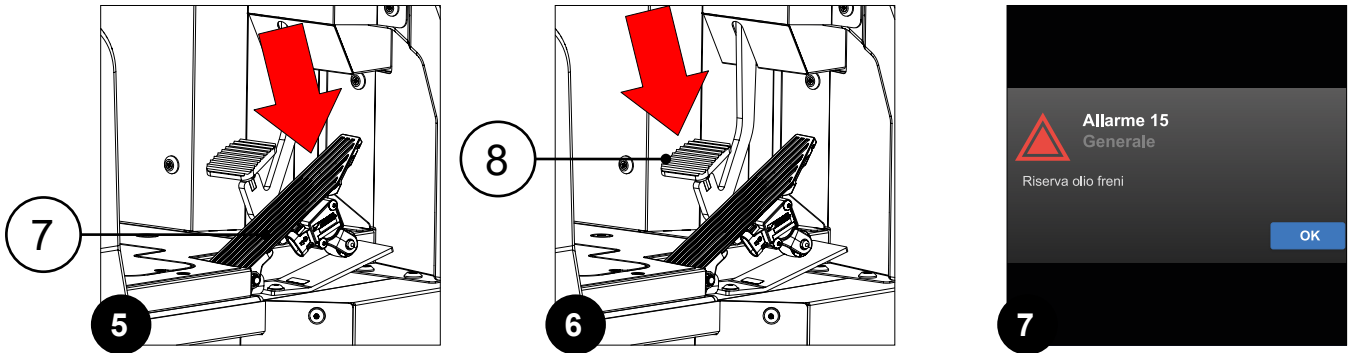

! **ATTENTION:** when the alarm symbol (9) appears on the main screen (**Fig.4**), stop the machine and contact a FIMAP service centre, see [“ALARM SCREEN” on page 93.](#)

i **N.B.:** Drive the machine slowly on inclines and descents. Use the brake pedal to control the machine speed. Where there is a stop, carry out the scrubbing by moving the machine upwards rather than downwards.

! **ATTENTION:** slow down on ramps and slippery surfaces.

! **ATTENTION:** Do not use the machine in areas where the ambient temperature is higher than 43°C (110°F). Do not use the scrubbing functions in areas where the ambient temperature is less than freezing 0°C (32°F).

! **ATTENTION:** to check what gradient of slope the machine can safely work or be transported on, contact your FIMAP service centre of reference or the one nearest to you, or visit the website www.fimap.com.

i **N.B.:** if the solution in the recovery tank should reach the critical level during the work activities, the critical level symbol (9) will appear on the main screen (**Fig.4**). To continue working, see [“OVERFLOW DEVICE” on page 78.](#)

i **N.B.:** the alarm symbol (9) will only disappear once the machine has been turned off and the recovery tank has been emptied.

i **N.B.:** if the detergent solution in the solution tank finishes while working, the critical level symbol (10) will appear on the main screen (**Fig.4**). To continue working, see [“DETERGENT SOLUTION” on page 46.](#)

i **N.B.:** the alarm symbol (10) will disappear as soon as the solution tank is filled.

The combined version is equipped with a sweeping brush head at the front of the machine. The combined version enables waste collection operations to be performed at the same time as floor scrubbing operations, thus halving working time and costs.

- i** **N.B.:** with the combined version, it is no longer necessary to waste time sweeping before scrubbing, and as such, it is no longer necessary to own two separate machines to carry out the two actions separately.
- i** **N.B.:** the combined version performs the work of a sweeping machine and a scrubbing machine in a single pass.
- i** **N.B.:** the sweeping brush head ensures efficient waste collection, keeping dust completely under control.

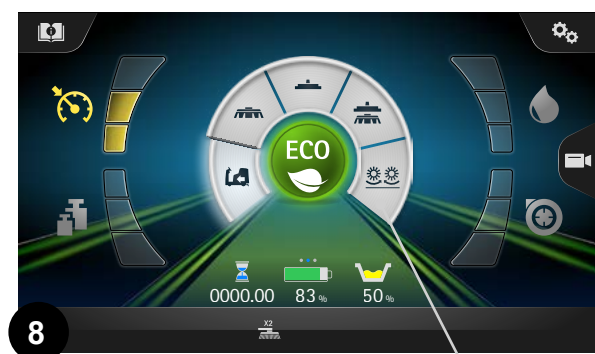

If it is necessary to use the sweeping brush head during the work, activate “SWEEPING” working mode, pressing on the icon (9) on the control display (Fig.8), see [“WORKING MODE” on page 70](#).

To activate the two side brushes, press the button (10) on the main screen (Fig.9), see [“SIDE BRUSH \(COMBINED VERSION\)” on page 98](#).

- i** **N.B.:** the side brush is active when the symbol (10) is green in colour.

Press the drive pedal (7) (Fig.5) to begin moving the machine.



- i** **N.B.:** as soon as the pedal (7) is pressed, the sweeping brush head is automatically moved to the working position.

- i** **N.B.:** the brush motors; the debris hopper suction motor is only activated once the sweeping brush head is in its working position.

- i** **N.B.:** to adjust the debris hopper vacuum performance, press the icon (14) on the main screen (Fig.9), see [“VACUUM SYSTEM DEBRIS HOPPER PERFORMANCE ADJUSTMENT \(COMBINED VERSION\)” on page 86](#).

- i** **N.B.:** if the pedal (7) is released when working, after a few seconds the sweeping brush head is automatically positioned in the rest position. When the sweeping brush head is being raised, the suction motor is switched off automatically.

- i** **N.B.:** to change the reset delay time related to the brush head control actuator, contact a FIMAP service centre or see [“MODIFICARE IL PARAMETRO RESET DELAY \(BRUSH - SWEEP MOT\)” on page 44](#), of the "OPERATOR INTERFACE CONFIGURATION MANUAL", which can be downloaded from the site www.fimap.com

- i** **N.B.:** drive the machine along the most linear path possible. Avoid hitting any obstacles and scratching the sides of the machine. Overlap the working widths by several centimetres.

- i** **N.B.:** avoid turning the steering wheel too sharply while the machine is in motion. The machine reacts quickly to the steering wheel's movements.

- i** **N.B.:** adjust the machine speed, the brush pressure and the flow of the solution based on the type of cleaning to be carried out.
- i** **N.B.:** The machine's service brake pedal (8), which is used to stop the machine when required (**Fig.6**), is located to the right of the footboard.
- i** **N.B.:** when the service brake pedal (8) is pressed, the red rear lights become brighter to indicate that the service brake pedal has been pressed.
- i** **N.B.:** the machine has an encoder to assist with braking, as well as a mechanical brake. If the machine is moving and the accelerator pedal (7) is released, the machine brakes, decelerating gently, until it stops the encoder. Only when the encoder has stopped is the electric brake engaged. If the machine is moving and the brake pedal (8) (**Fig.6**) is pressed, the machine brakes with the braking force applied by the mechanical system. Only when the encoder has stopped is the electric brake engaged.
- i** **N.B.:** upon request, the machine is equipped with an anti-collision system which, upon detection of obstacles or other vehicles, will perform a controlled emergency braking, see [“ANTI-COLLISION SYSTEM” on page 91.](#)
- !** **ATTENTION:** when the alarm symbol (11) appears on the main screen (**Fig.4**) in addition to the pop-up window (**Fig.7**), this means that the level of oil in the braking system is low, stop the machine and contact a FIMAP service centre.
- !** **ATTENTION:** when the alarm symbol (9) appears on the main screen (**Fig.4**), stop the machine and contact a FIMAP service centre, see [“ALARM SCREEN” on page 93.](#)
- i** **N.B.:** Drive the machine slowly on inclines and descents. Use the brake pedal to control the machine speed. Where there is a stop, carry out the scrubbing by moving the machine upwards rather than downwards.
- !** **ATTENTION:** slow down on ramps and slippery surfaces.
- !** **ATTENTION:** Do not use the machine in areas where the ambient temperature is higher than 43°C (110°F). Do not use the scrubbing functions in areas where the ambient temperature is less than freezing 0°C (32°F).
- !** **ATTENTION:** to check what gradient of slope the combined version machine can safely work or be transported on, contact your FIMAP service centre of reference or the one nearest to you, or visit the website www.fimap.com.

HOUR METER

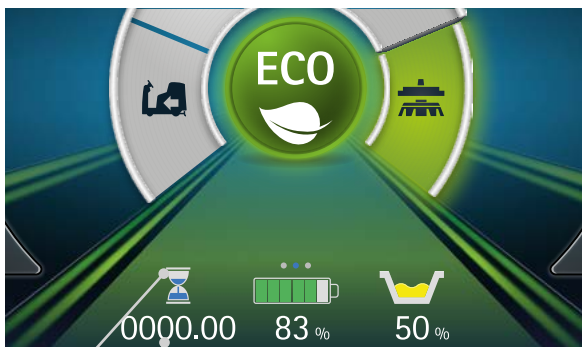

The lower left section of the main screen displays the hour meter, which consists of a symbol (1) and the number value (2).

- i** **N.B.:** The number value (2) allows the user to view the machine's total time of use via a series of numbers.
- i** **N.B.:** the digits preceding the (“.”) identify the hours, while the digits that come after the “.” identify the tenths of an hour, a tenth of an hour corresponds to six minutes.
- i** **N.B.:** to change the hour meter displayed on the control display, contact a FIMAP service centre or see [“CHANGING THE TYPE OF HOUR METER ON THE DISPLAY \(GENERAL - HOUR METER\)” on page 85.](#)

BATTERY BOX CHARGE LEVEL INDICATOR



The lower central section of the main screen displays the battery box level represented by a symbol (3) in the shape of a AA battery (4) that identifies the percentage of charge.

i **N.B.:** the battery state of charge percentage is calculated with respect to their maximum capacity, and the function board transforms the voltage value of the batteries into a percentage value.

i **N.B.:** the battery level icon (3) is composed of six charge levels, each of which represents about 16% of residual charge.

i **N.B.:** the graphic symbol (3) turns green  when the residual charge is in the following value range 100% - 51%.

i **N.B.:** the graphic symbol (3) turns yellow  when the residual charge is in the following value range 50% - 17%.

i **N.B.:** the graphic symbol (3) turns red  when the residual charge is in the following value range 16% - 01%.

i **N.B.:** the graphic symbol (3) turns red  when the residual charge is 00%.

i **N.B.:** with a residual charge of 16%, the graphic symbol will start to flash and after a few seconds it will turn red. In these conditions, take the machine to the place where the battery box can be charged.

i **N.B.:** after a few seconds, the residual charges reaches 20%, the brush motor switches off automatically. The remaining charge is sufficient for completing the drying task before recharging the battery box.

i **N.B.:** a few seconds after the battery charge level reaches 10%, the suction motor switches off automatically. With the remaining charge, it is still possible, however, to move the machine to the designated battery box recharging station.

i **N.B.:** the function board in the machine is programmed by the factory to work with the following type of battery: 36Pb80, to change please [“MODIFICARE LA TIPOLOGIA DI BATTERIA SELEZIONATA \(GENERAL - BATTERY\)” on page 26](#) of the “OPERATOR INTERFACE CONFIGURATION MANUAL” which can be downloaded from the site www.fimap.com

SOLUTION TANK FILL LEVEL INDICATOR





The lower right section of the main screen displays the solution tank filling level, represented by a graphic symbol (5) and a numerical value (6) that identifies the percentage of filling.

i **N.B.:** the solution tank filling percentage is calculated with respect to the maximum capacity the function board transforms the value received from the electric float into a percentage value.

i **N.B.:** the graphic symbol (6) turns green  when the filling percentage is in the following value range 100% - 51%.



i **N.B.:** the graphic symbol (6) turns yellow  when the filling percentage is in the following value range 50% - 21%.

i **N.B.:** the graphic symbol (6) turns red  when the filling percentage is in the following value range 20% - --%.

i **N.B.:** the graphic symbol (6) will have only a red silhouette  when the residual filling percentage is -- %.

i **N.B.:** when the capacity arrives at a percentage below 20%, the main screen displays the reserve symbol , which will disappear only when the solution tank is filled, see [“DETERGENT SOLUTION” on page 46](#).

OVERFLOW DEVICE

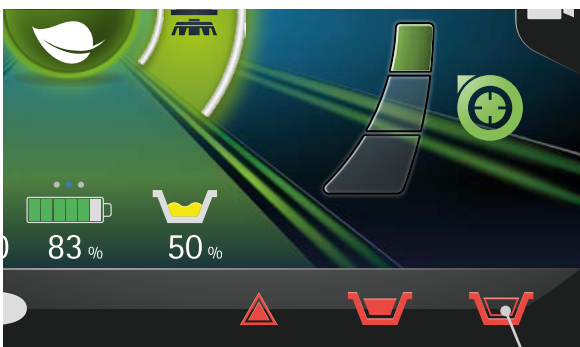

The machine has an overflow device, when the level of solution in the recovery tank arrives at a critical level, the alarm (1) appears on the control display.

As soon as the alarm appears, do the following:

1. Stop the machine.
2. Activate the TRANSFER working mode, see [“DS SELECTOR \(DRIVE SELECT\)” on page 87](#).
3. Take the machine to the designated maintenance area.
4. Perform the recovery tank emptying procedure, see [“EMPTYING THE RECOVERY TANK” on page 87](#).



EMPTYING THE DEBRIS HOPPER (CYLINDRICAL VERSION)

When cleaning the floor, if you notice that the machine can no longer collect the dirt from the floor, this could be due to the debris hopper in the scrubbing brush head being full.

The careful cleaning of the debris hopper in the scrubbing brush head will ensure better floor cleaning, thus decreasing costs while at the same time improving environmental sustainability and performance.

To empty the debris hopper, proceed as follows:

1. Take the machine to the maintenance area.

N.B.: the place designated for this operation must comply with current regulations concerning safety at work and current environmental protection regulations.

2. Sit on the driver's seat.
3. Insert the key (1) into the slot (2) on the right side of the column (**Fig.1**).
4. Turn on the machine and turn the key (1) a quarter turn clockwise (**Fig.2**).
5. Press the button (3) present on the control panel (**Fig.3**) to activate the MAINTENANCE POSITION function, see ["SERVICE FUNCTION" on page 86](#).

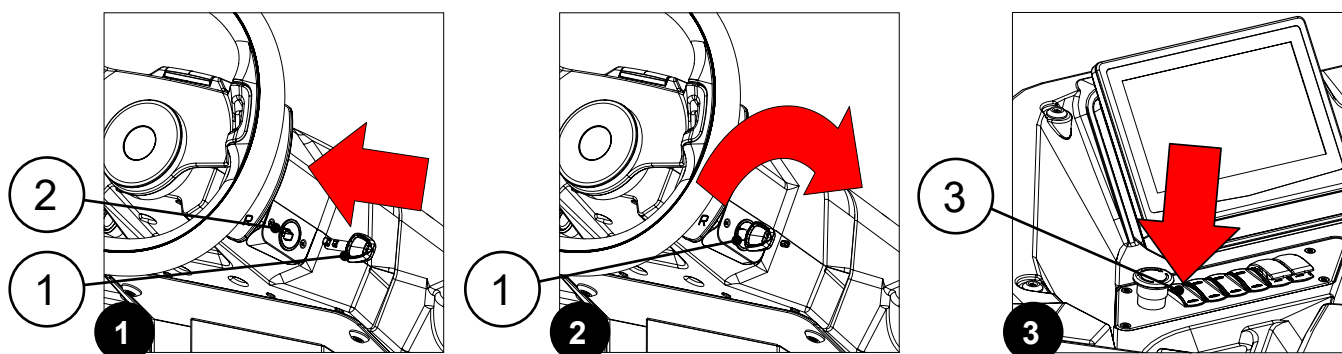

6. Open the left inspection door (4) (**Fig.4**).
7. Remove the debris hopper from the machine using the handle (5); before moving the hopper, remember to release the debris hopper latch (6) (**Fig.5**).
8. Move the debris hopper in the place used for waste disposal using the handle (5).

N.B.: the place designated for this operation must comply with current regulations concerning safety at work and current environmental protection regulations.

9. Clean the inside of the debris hopper with a stream of running water, using a brush to remove any dirt residues if necessary.
10. Take out the debris hopper vacuum filter (7) (**Fig.6**), clean it with a jet of water, and if necessary use a scraper to remove any residues of dirt.
11. Proceed in the opposite order to reassemble all the parts.

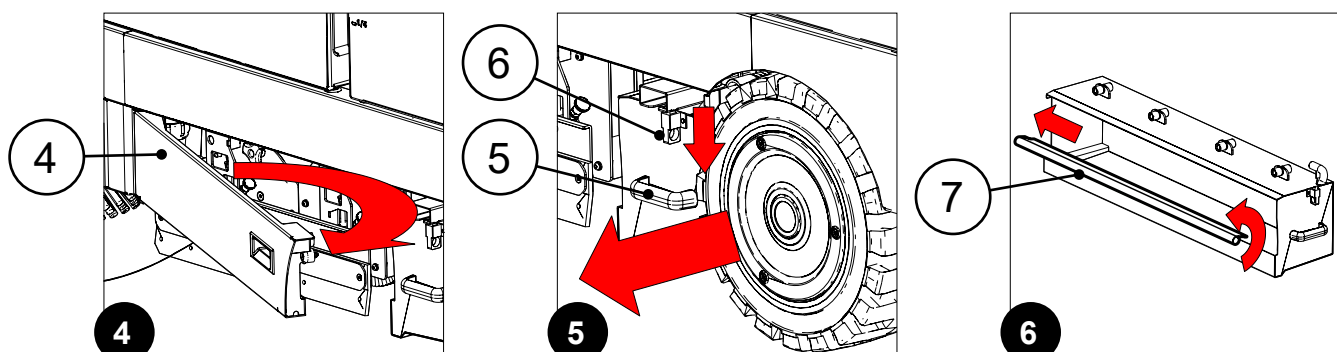

EMPTYING THE DEBRIS HOPPER (COMBINED VERSION)

When cleaning the floor, if you notice that the machine can no longer collect the dirt from the floor, this could be due to the debris hopper in the scrubbing brush head being full.

To empty the debris hopper, proceed as follows:

1. Take the machine to the designated waste disposal area.



N.B.: the place designated for this operation must comply with current regulations concerning safety at work and current environmental protection regulations.

2. Bring the front of the machine close to the waste container.



WARNING: calculate the distance between the machine and the waste container correctly, bearing in mind the rotation radius of the debris hopper when moving.

3. Activate the filter shaker by pressing the "FILTER SHAKER CONTROL" button (1) on the control panel (**Fig.1**).



ATTENTION: Do not keep the switch (1) pressed longer than ten seconds; repeat this operation two or three times.

4. Raise the debris hopper into the emptying position, press the "MOVE THE DEBRIS HOPPER UPWARDS" button (2) on the control panel (**Fig.1**).

5. Bring the machine close to the waste container, so that the debris hopper is inside the container opening, and move closer to the waste container.



WARNING: reduce the machine movement speed when the debris hopper is lifted off the ground.



WARNING: avoid moving the machine on a slope when the debris hopper is lifted off the ground.



WARNING: do not activate the filter shaker while the debris hopper is lifted off the ground.

6. Once in waste emptying position, stop the machine and rotate the debris hopper into the emptying position, press the "ROTATE DEBRIS HOPPER" button (3) on the control panel (**Fig.1**).



N.B.: as soon as the debris hopper begins to rotate, the debris will begin to come out.

7. Once the debris has been completely unloaded, rotate the debris hopper into the working position, release the button (3).



N.B.: on releasing the button (3), the machine will automatically bring the debris hopper into the loading position.

8. Move the machine away from the waste container.



WARNING: reduce the machine movement speed when the debris hopper is lifted off the ground.



WARNING: calculate the distance between the machine and the waste container correctly, bearing in mind the rotation radius of the debris hopper when moving.

9. Lower the debris hopper, whilst simultaneously pressing the "MOVING THE DEBRIS HOPPER

DOWNWARDS” button (4), which is located on the control panel (**Fig.1**), and the “OPERATOR PRESENT” button (5) which is located on the left-hand side of the steering column (**Fig.2**).

i **N.B.:** If the debris hopper is not rotated fully into the loading position before being lowered into the working position, the machine will automatically stop lowering when it reaches the safety position. The lowering of the debris hopper into the working position will only continue when the debris hopper is fully rotated into the loading position.

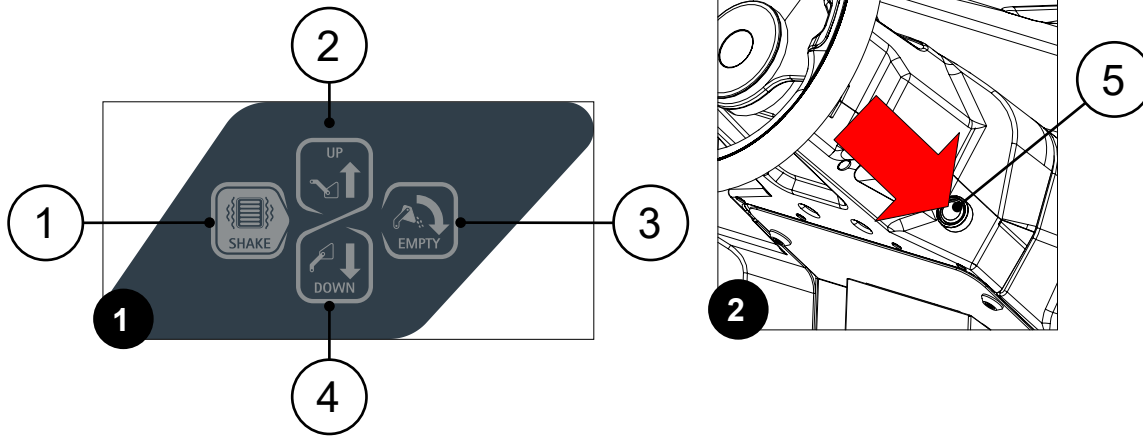

i **N.B.:** the machine only allows rotation of the debris hopper into the unloading position at a height that is considered safe for the machine.

ADDITIONAL FUNCTIONS

ADJUSTING THE PRESSURE EXERTED ON THE BRUSH HEAD

To adjust the pressure exerted on the brush head, proceed as follows:

1. During the first meters of work, check that the pressure exerted on the brush head is enough to remove the dirt on the floor, but not too much to ruin the floor itself.
2. To adjust the pressure exerted on the brushes, press the button (1) on the membrane push-button panel (Fig.1) or press the symbol (2) on the main screen (Fig.2).

i **N.B.:** pressing the button (1) or the symbol (2) switches to the manual program (Fig.3), see [“MANUAL MODE WORKING PROGRAM” on page 68](#) .

i **N.B.:** the exercised pressure can be adjusted to three levels, from 1 to 3. The level is shown with the symbol (3) on the main screen (Fig. 3). The change the values relating to the pressure exerted on the brush head, see [“MODIFICARE IL PARAMETRO PRESSURE LEVEL \(Sum\) \(BRUSH - BRUSH MOT\)” on page 42](#) of the “OPERATOR INTERFACE CONFIGURATION MANUAL” which can be downloaded from the site www.fimap.com

i **N.B.:** in sweeping mode, the pressure exerted on the brush head cannot be adjusted; to change the standard value, see [“MODIFICARE IL PARAMETRO PRESSURE LEVEL \(Sum\) \(BRUSH - SWEEP MOT\)” on page 46](#) of the “OPERATOR INTERFACE CONFIGURATION MANUAL” which can be downloaded from the site www.fimap.com

i **N.B.:** each press of the button (1) or the symbol (2), cyclically increases the level of detergent solution in the machine's water system.

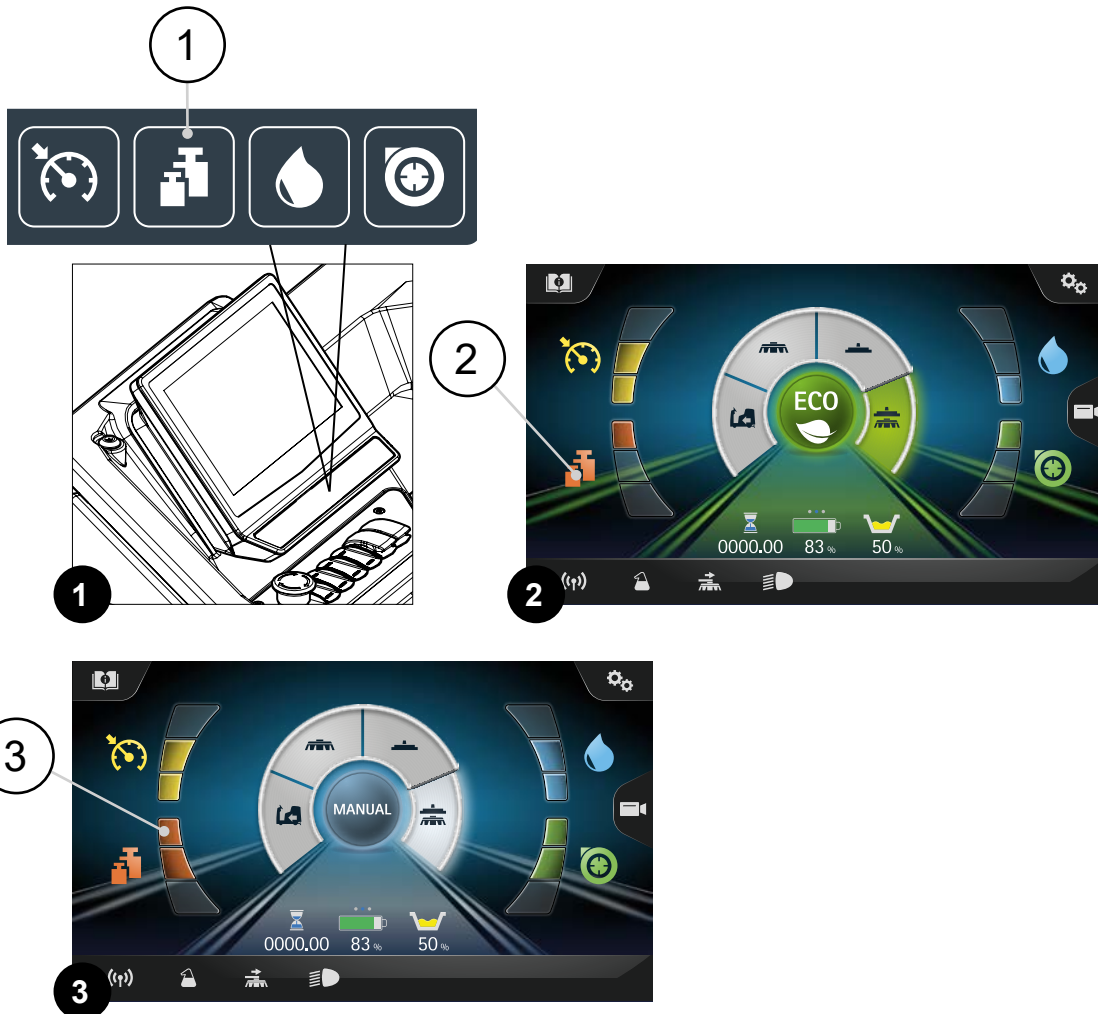

REGULATING THE FORWARD SPEED

To adjust the forward speed, proceed as follows:

1. During the first few metres, check that the forward speed is adequate to the grip conditions.
2. To adjust the speed, press the button (1) on the membrane push-button panel (**Fig.1**) or press the symbol (2) on the main screen (**Fig.2**).

i **N.B.:** pressing the button (1) or the symbol (2) switches to the manual program (**Fig.3**), see [“MANUAL MODE WORKING PROGRAM”](#) on page 68.

i **N.B.:** the forward speed can be adjusted to three levels, from 1 to 3. The level is shown with the symbol (3) on the main screen (**Fig. 3**). To change the values relating to the forward speed of the machine, see [“MODIFICARE IL PARAMETRO SPEED LEVEL \(TRACTION - SPEED SETS\)”](#) on page 67 of the “OPERATOR INTERFACE CONFIGURATION MANUAL” which can be downloaded from the site www.fimap.com

i **N.B.:** each press of the button (1) or the symbol (2), cyclically increases the speed level.

i **N.B.:** the machine forward speed can be adjusted by pressing the pedal (4) more or less (**Fig.4**). The more you press, the higher the speed (within the limits of the level selected beforehand).

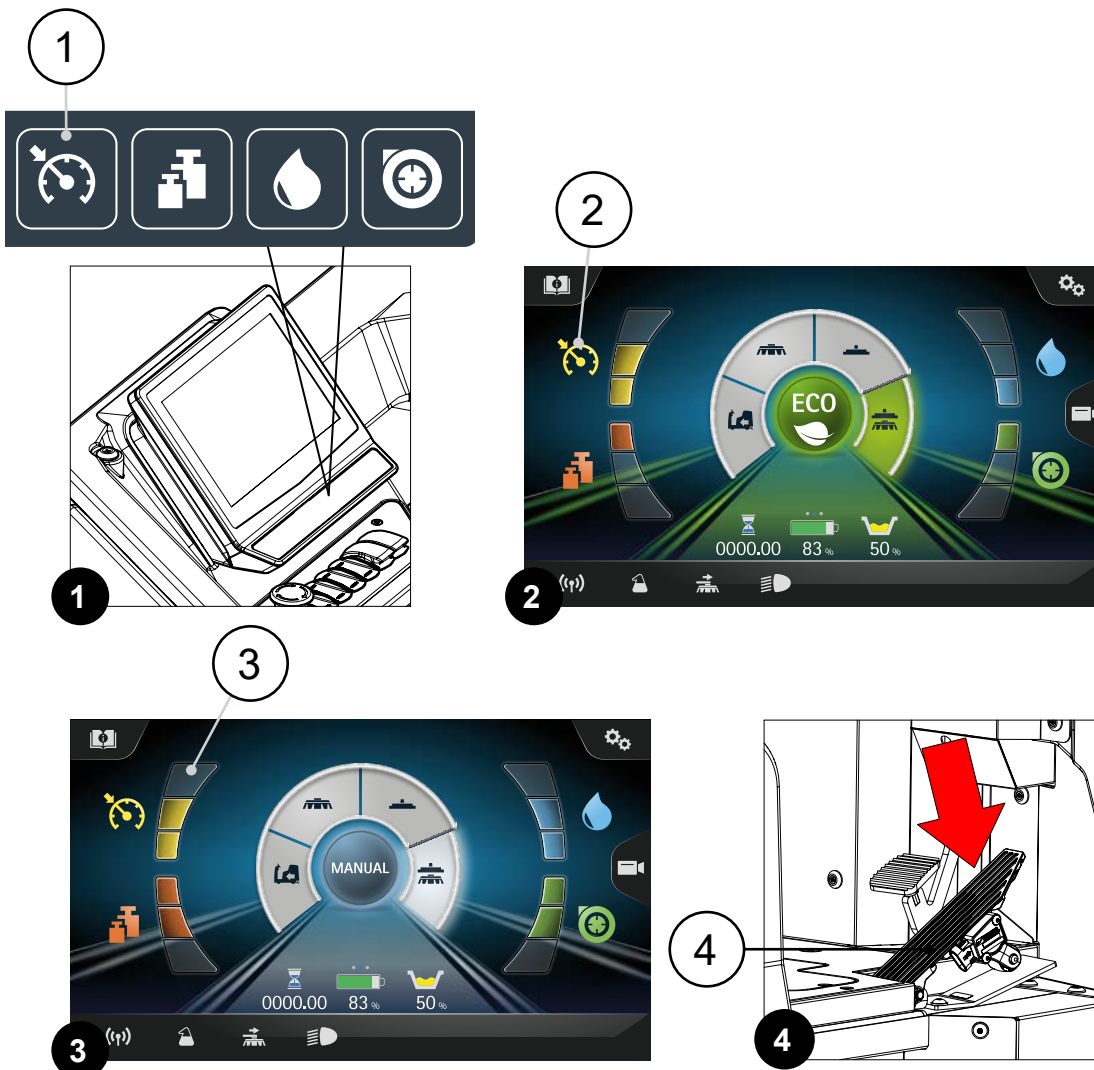

ADJUSTMENT OF THE DETERGENT SOLUTION FLOW

To adjust the flow of detergent solution, proceed as follows:

1. During the first few working meters check that the amount of solution is sufficient to wet the floor, but not excessive to exit the splash guard.
2. To adjust the quantity of detergent solution, press the button (1) on the membrane push-button panel (**Fig.1**) or press the symbol (2) on the main screen (**Fig.2**).

i **N.B.:** pressing the button (1) or the symbol (2) switches to the manual program (**Fig.3**), see [“MANUAL MODE WORKING PROGRAM”](#) on page 68.

i **N.B.:** The flow of detergent solution on the brush can be adjusted to one of four levels, from 0 to 3. The level is shown with the symbol (3) on the main screen (**Fig.3**). To change the values relating to the quantity of detergent solution in the water system of the machine, see [“MODIFICARE IL PARAMETRO PUMP LEVEL \(Sum\) \(PUMP - WATER\)”](#) on page 49 of the “OPERATOR INTERFACE CONFIGURATION MANUAL” which can be downloaded from the site www.fimap.com

i **N.B.:** each press of the button (1) or the symbol (2), cyclically increases the level of detergent solution in the machine's water system.

i **N.B.:** If the flow is set to 0, there is no emission of detergent solution.

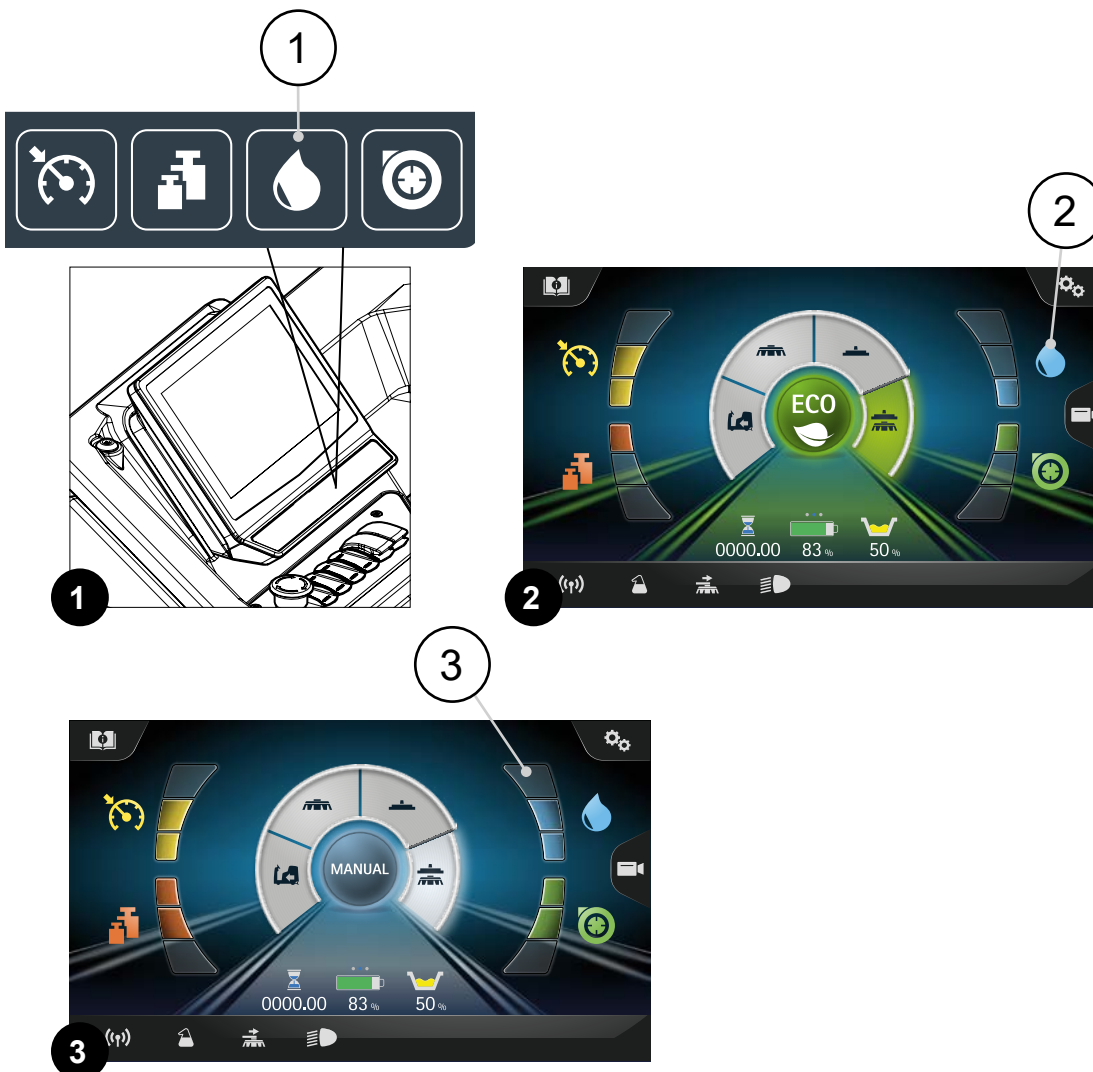

VACUUM SYSTEM PERFORMANCE ADJUSTMENT (SCRUBBING VERSION)

To adjust the performance of the vacuum system, proceed as follows:

1. during the first meters of work, check that the vacuum system collects the solution on the floor perfectly.
2. To adjust the performance of the vacuum system, press the button (1) on the membrane push-button panel (**Fig.1**) or press the symbol (2) on the main screen (**Fig.2**).

i **N.B.:** pressing the button (1) or the symbol (2) switches to the manual program (**Fig.3**), see [“MANUAL MODE WORKING PROGRAM”](#) on page 68 .

i **N.B.:** the performance of the vacuum system can be adjusted to three levels, from 1 to 3. The level is shown with the symbol (3) on the main screen (**Fig. 3**). To change the values relating to the performance of the vacuum system of the machine, see [“MODIFICARE IL PARAMETRO VACUUM NOISE LEVEL \(VACUUM - VAC. MOTOR\)”](#) on page 54 of the “OPERATOR INTERFACE CONFIGURATION MANUAL” which can be downloaded from the site www.fimap.com

i **N.B.:** each press of the button (1) or the symbol (2) cyclically increases the performance level of the machine's vacuum system.

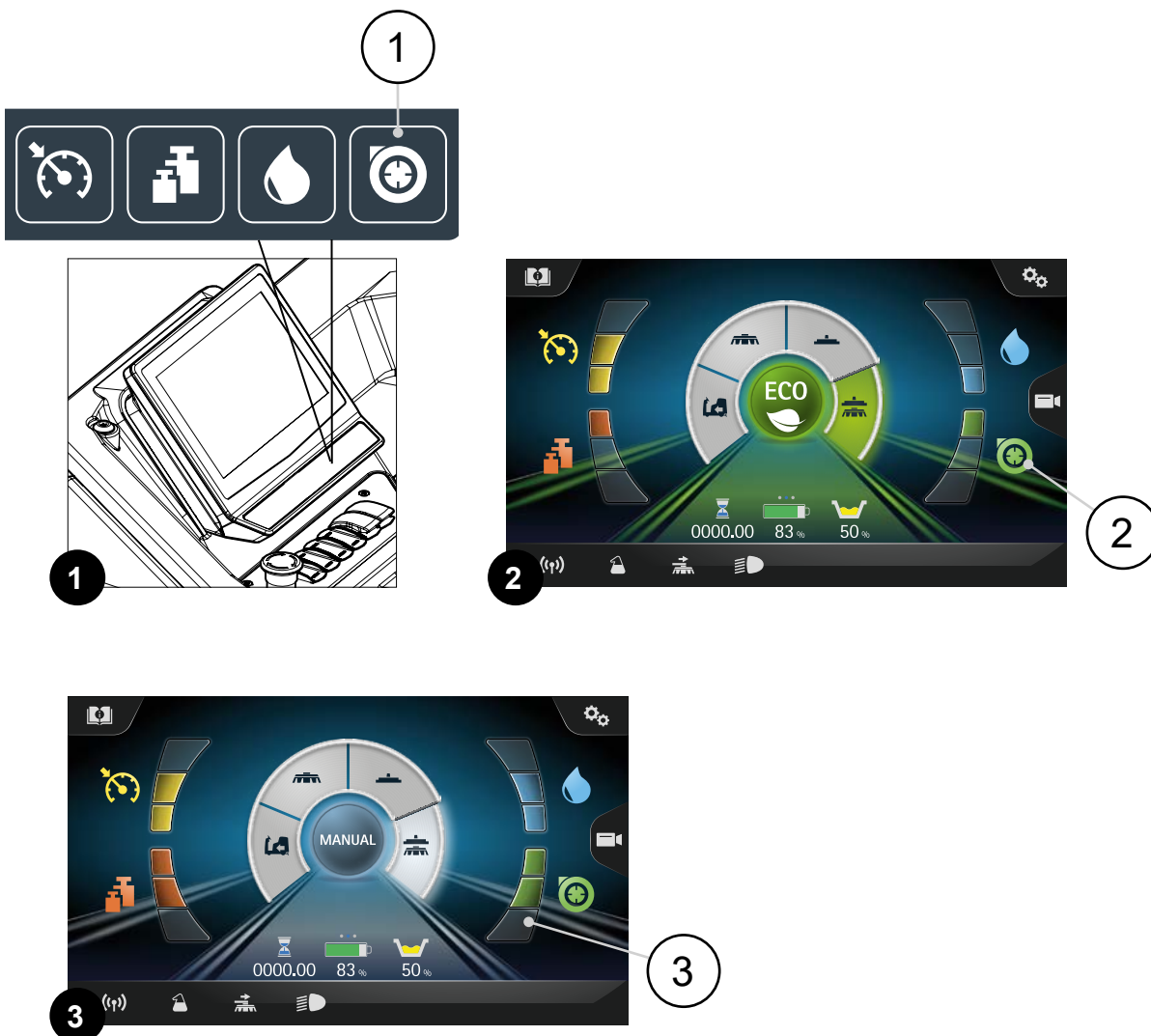

**VACUUM SYSTEM DEBRIS HOPPER PERFORMANCE ADJUSTMENT
(COMBINED VERSION)**



To adjust the performance of the vacuum system, proceed as follows:

1. During the first meters of work, check that the vacuum system is collecting all the dust present during the floor cleaning activity.
2. To adjust the performance of the vacuum system, press the symbol (1) present on the main screen (**Fig.1**).

i **N.B.:** the performance of the vacuum system can be adjusted to four levels, from a minimum of 0 to a maximum of 3. The level is shown with the symbol (2) on the main screen (**Fig. 1**). To change the values relating to the performance of the vacuum system of the machine, see [“MODIFICARE IL PARAMETRO VACUUM NOISE LEVEL \(VACUUM - SWEEP VAC. MOTOR\)”](#) on page 55 in of the

“OPERATOR INTERFACE CONFIGURATION MANUAL” which can be downloaded from the site www.fimap.com

i **N.B.:** each press of the symbol (1) cyclically increases the performance level of the machine's debris hopper vacuum system.

i **N.B.:** with the vacuum system at level 0, the vacuum function in the debris hopper is not on.

SERVICE FUNCTION

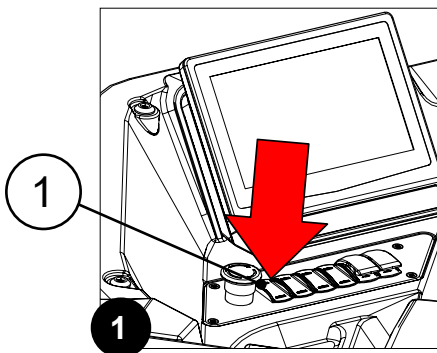

The machine is equipped with a button that activates the service function, when it is necessary to automatically position both the brush head and the squeegee in the rest position raised from the floor. To activate the function, proceed as follows:

1. Place the machine in the TRANSFER working mode, see [“DS SELECTOR \(DRIVE SELECT\)”](#) on page 70.
2. Activate the service function, press the BRUSH UNCOUPLING button (2) on the control panel (**Fig.2**).

i **N.B.:** with the service function, both the brush head and the squeegee are automatically moved to the intermediate position (referred to as the extra position) by the machine.

i **N.B.:** once the service sequence has been activated, it is not possible to activate other functions or move the machine.

! **CAUTION:** make sure that no people or objects are in the machine's vicinity during this operation.

BRUSH UNCOUPLING FUNCTION (DISCOID SCRUBBING VERSION)

The machine is equipped with a button that activates the brush uncoupling function, when it is necessary to carry out maintenance or replace the brushes in the brush head. To activate the function, proceed as follows:

1. Check that the working mode activated on the machine is TRANSFER, otherwise press the button (1) on the control display (**Fig.1**), see [“DS SELECTOR \(DRIVE SELECT\)”](#) on page 70.
2. Press the MAINTENANCE (2) button on the control panel for at least three seconds (**Fig.2**).
3. The machine will automatically perform the BRUSH UNCOUPLING function.

i **N.B.:** once the maintenance sequence has been activated, it is not possible to activate other functions or move the machine.

! **CAUTION:** make sure that no people or objects are in the machine's vicinity during this operation.

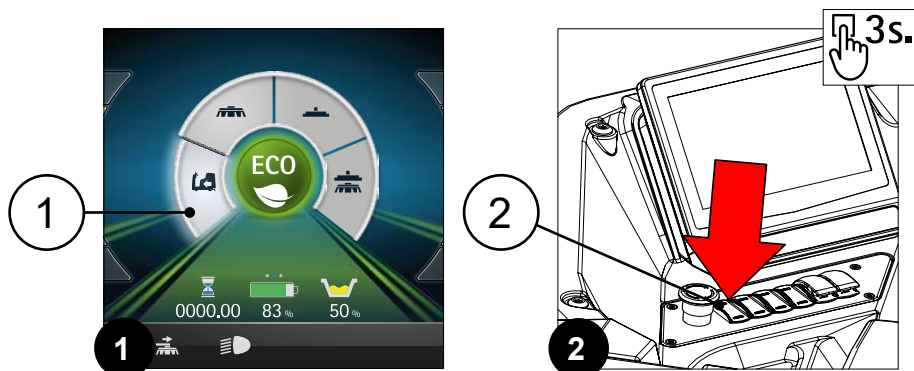

BUZZER

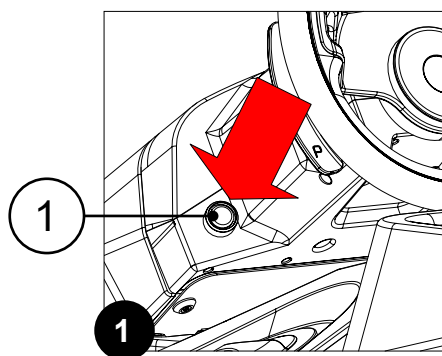

The machine is equipped with a buzzer. if you need to sound a warning, just press the button (1) on the steering column (**Fig.1**).

SERVICE LIGHTS

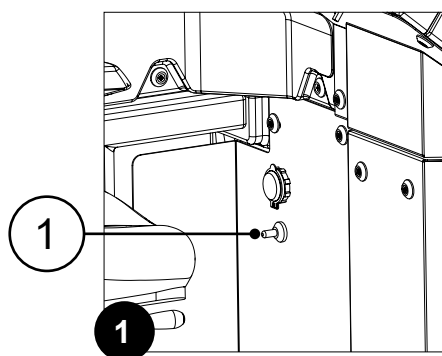

Upon request, the machine can be equipped with the exclusive service lights pack. The service lights package offers increased visibility of the parts which could require operator inspection, illuminating the relative zones with LED lights.

To activate the service lights, use the switch (1) under the control panel (**Fig.1**). This switch has three working positions:

- ON: set the switch to this position when you want the service lights to remain on, regardless of the status of the microswitches in the various doors.
- OFF: set the switch to this position when you want the service lights to remain off.
- AUTOMATIC: set the switch to this position when you want the service lights to only turn on when the microswitches in the various doors are engaged.

EMERGENCY BUTTON

The machine is equipped with an emergency button. If any problems are encountered during the work activities, do the following:

1. Press the emergency button (1) on the control panel (**Fig.1**).

CAUTION: this command interrupts the electrical circuit that goes from the batteries to the machine system.

2. Once the machine has stopped, turn the main switch to its "0" position by turning the key (2) a quarter turn anti-clockwise (**Fig.2**).
3. Disengage the emergency button (1) by turning it in the direction indicated by the arrows printed on it.
4. Eliminate the anomaly that caused the problem.

N.B.: If the anomaly persists, contact a technician at the FIMAP service centre.

5. Carry out all the procedures for turning on the machine.

N.B.: in the PLUS versions, as soon as the button (1) is pressed on the main screen, the pop-up alarm shown in **Fig.3** appears alternating with the alarm pop-up shown in **Fig.4**.

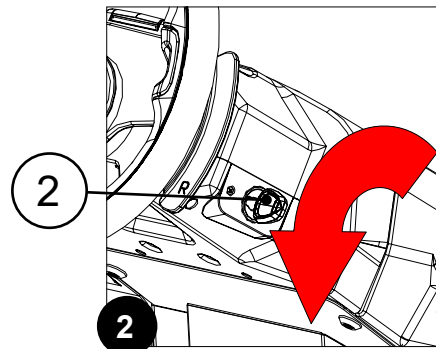
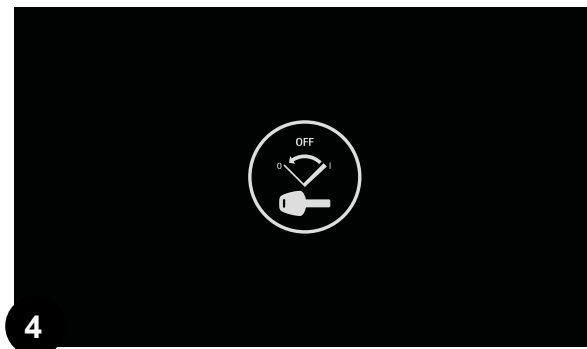
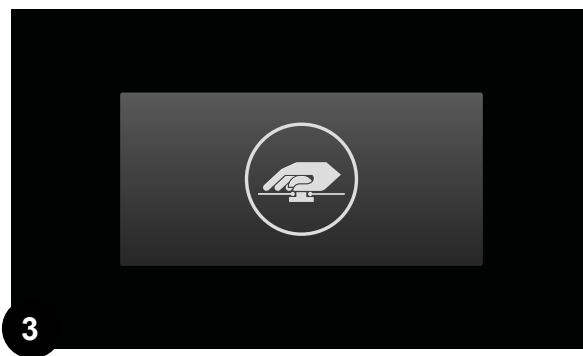
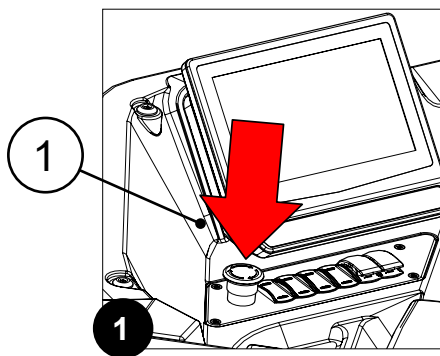

BRAKING CONTROL

The machine has an encoder to assist with braking, as well as a mechanical brake. If the machine is moving and the accelerator pedal (1) (**Fig.1**) is released, the machine brakes, decelerating softly, until it stops the encoder.

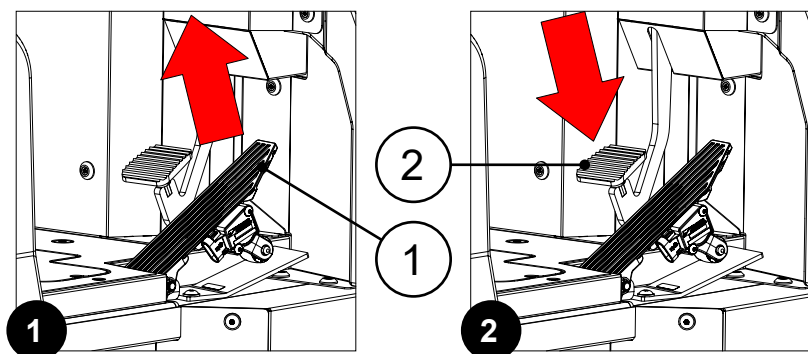

i **N.B.:** If the machine is moving and the brake pedal (2) (**Fig.2**) is pressed, the machine brakes with the braking force applied by the mechanical system.

! **WARNING:** Only when the encoder has stopped is the electric brake engaged.

REVERSE GEAR

The machine is equipped with electronic traction control. To engage the reverse gear, do the following:

1. Stop the machine.
2. Engage the "REVERSE GEAR ACTIVATION/DEACTIVATION" lever (1) underneath the steering wheel (**Fig.1**).
3. Press the drive pedal (2) (**Fig.2**) to start the machine moving in reverse.

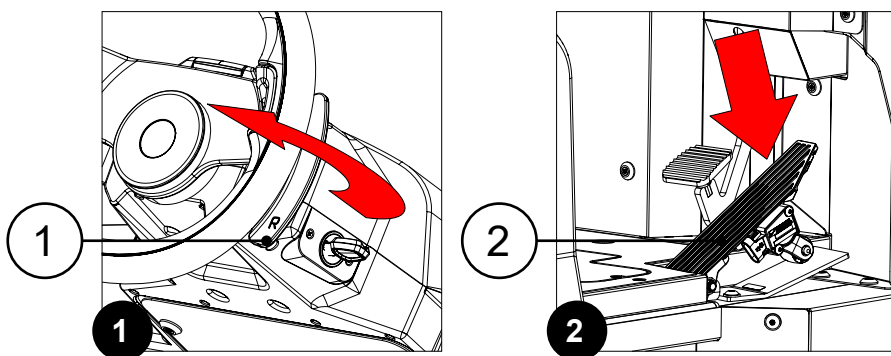

! **CAUTION:** the reversing speed is lower than the forward speed, in line with the current regulations on safety at work; to change the reverse speed, see "[MODIFICARE IL PARAMETRO MAX SPEED BACKWARD \(TRACTION - PAR. CHANGE\)](#)" on page 65 of the "OPERATOR INTERFACE CONFIGURATION MANUAL" which can be downloaded from the site www.fimap.com

i **N.B.:** in order to disengage the reverse gear, move the lever (1) underneath the steering wheel again.

i **N.B.:** Once the lever has been engaged (1), the acoustic signalling device will be activated in order to signal that the machine's reverse gear has been engaged.

i **N.B.:** if you reverse with the squeegee in the working position, as soon as you press the drive pedal, the machine will start to move backwards and the squeegee will lift off the floor; to change the reset delay time relating to the squeegee control actuator, see [“MODIFICARE IL PARAMETRO TRACTION REVERSE DELAY \(ACTUATOR - SQUEEGE\)”](#) on page 61 of the "OPERATOR INTERFACE CONFIGURATION MANUAL" which can be downloaded from the site www.fimap.com

i **N.B.:** If reverse is engaged with the brush head in its working position, once the drive pedal is pressed, the machine will begin to move in reverse and the brush head will remain in its working position, but the solenoid valve will stop dispensing detergent solution to the brushes.

i **N.B.:** if you reverse with the side brush head in the working position, as soon as you press the drive pedal, the machine will start to move backwards and the side brush head will return to its rest position; to change the reset delay time relating to the side brush brush head control actuator, see [“MODIFICARE IL PARAMETRO RESET DELAY \(Act. After Stop Traction \(Vac. Motor\)\) \(VACUUM - VAC. MOTOR\)”](#) on page 53 of the "OPERATOR INTERFACE CONFIGURATION MANUAL" which can be downloaded from the site www.fimap.com

i **N.B.:** while reversing, instead of the main screen, the image provided by the connected video camera will be displayed across the full screen.

i **N.B.:** The camera is a visual aid designed for use during reversing manoeuvres.

! **DANGER:** the rear camera system does not remove the responsibility of the driver to drive with due care and diligence.

i **N.B.:** keep the camera free of dirt. Do not clean with sharp objects, degreasers, wax or biological based products. Use only a soft cloth.

! **ATTENTION:** The distances shown on the display may differ from the actual distances.

! **WARNING:** do not place objects in front of the camera.



i **N.B.:** during operation, the display (**Fig.3**) shows the guide lines (3) that represent the vehicle path and the approximate distance of the objects behind it.

i **N.B.:** the guide lines (3) indicate the trajectory foreseen for the overall dimensions of the machine with the steering wheel in the current position. the guide lines (3) are projected on the screen as if they were on the ground behind the machine and depend directly on the movement of the steering wheel to show the driver the trajectory, also in a curve. The guide lines (3) are designed to recreate the most protruding parts of the machine.

a curve. The guide lines (3) are designed to recreate the most protruding parts of the machine.

! **ATTENTION:** remember that when the rear view camera is selected, the central display only shows the area behind the machine, therefore pay attention to the sides and to the front when turning in reverse.

ANTI-COLLISION SYSTEM

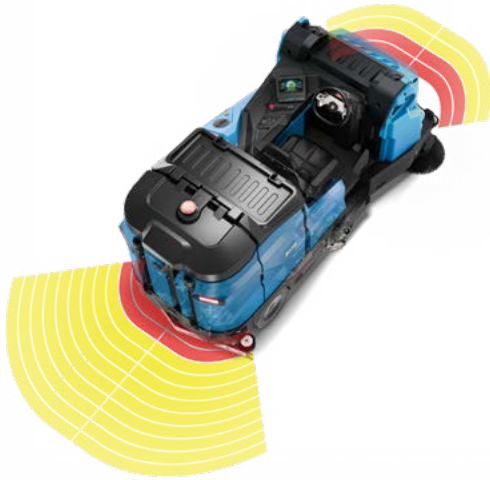

On request, the machine can be equipped with an anti-collision system.

The anti-collision system consists of obstacle detectors mounted on the front and rear of the machine.

The anti-collision system continuously emits infrared pulses, which are reflected on the obstacles they encounter and return back to a receiving antenna mounted in the said "radar". A special software, based on the speed of the vehicle and the distance from the obstacle, judges whether it can constitute a danger, in this case the system activates an audible alarm that varies as the distance of the obstacle varies.

i **N.B.:** the left part of the screen (**Fig.1**) displays a coloured distance bar (1), which shows the distance between the front and rear bumpers and the detected obstacle.

i **N.B.:** the colour codes for the distance bars (1) are: green has a range of between 0.8 and 1.5 meters; amber has a range of between 0.3 and 0.8 meters; red has a range of less than 0.3 metres.

i **N.B.:** during reverse, in addition to the distance bar (1), the anti-collision sensors manage the special function that modulates the ON/OFF frequency of the buzzer.

i **N.B.:** during forward movement, in addition to the distance bar (1), the anti-collision sensors manage the special function that modulates the ON/OFF frequency of the buzzer; the function will be activated at a shorter distance than when in reverse.

i **N.B.:** the anti-collision sensors' operating principle is based on the emission and reception of high frequency ultrasound waves. The return wave allows the sensor to detect the presence of an object and to measure its distance from the machine.

i **N.B.:** if the "Brake" function in the "Anti-collision" parameter is active, by moving the reverse lever, the function will start to slow the machine down automatically once a certain distance (set in the parameters) is reached. If the "Brake" function is active, the red symbol (2) will be visible in the control display. (**Fig.1**).

i **N.B.:** if the "Brake" function in the "Anti-collision" parameter is active, moving the "EXTRA-PRESSURE ACTIVATION/DEACTIVATION" lever (3) under the steering wheel (**Fig.2**) for more than three seconds will temporarily deactivate the "Brake" function; however, the function will be active and when approaching an obstacle, the machine will emit a sound.

i **N.B.:** if the symbol (2) is red, this means that the "Brake" function is active; if the symbol (2) is grey, this means that the "Brake" function is not active.

i **N.B.:** to change the parameters relating to the anti-collision function, see "[ATTIVARE O DISATTIVARE LA FUNZIONE ANTICOLLISION SYSTEM \(GENERAL - CONFIG\)](#)" on page 35 of the "OPERATOR INTERFACE CONFIGURATION MANUAL" which can be downloaded from the site www.fimap.com

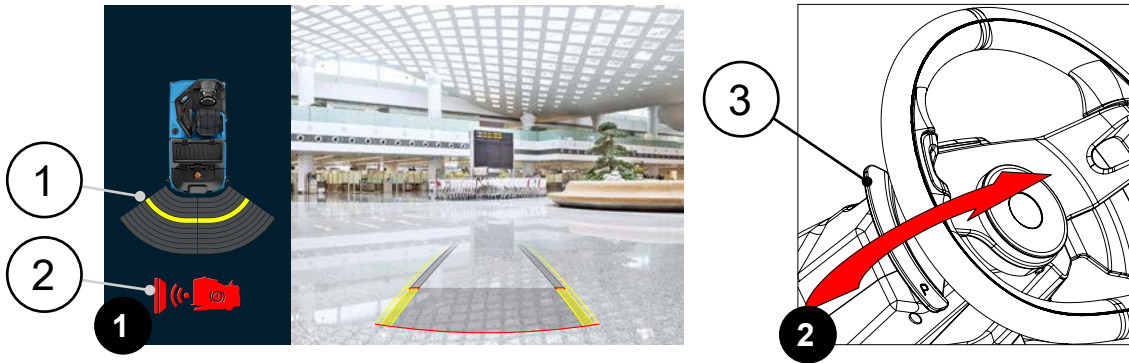

SMART DRYING MODE

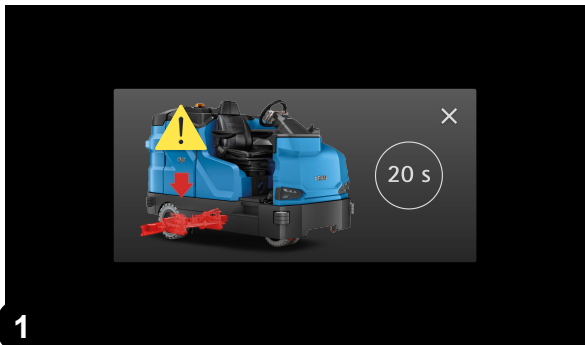

When switching from the scrubbing machine program to the transfer program, the drying function is delayed for a set period of time.

- i** **N.B.:** While the function is active, the image in **Fig.1** will be displayed on the control panel.
- i** **N.B.:** the delay time is displayed by the countdown on the screen **Fig.1**.

At the end of the preset time, the squeegee is moved to the rest position and the suction motor is switched off with its set delay time.

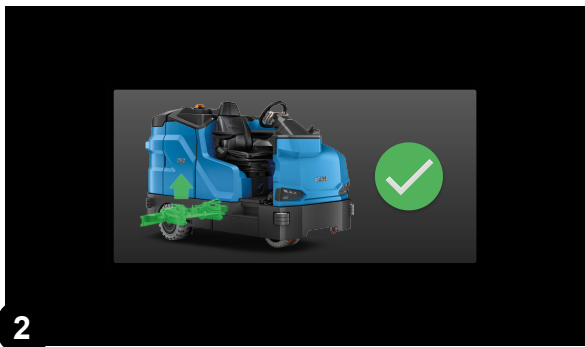

- i** **N.B.:** it is possible in any case to cancel this function in advance by pressing the "X" symbol as seen in **Fig.1**.
- i** **N.B.:** at the end of the smart drying function, the image in **Fig.2** will be displayed on the control panel.

WORKING HEADLIGHTS

Upon request, the machine can be equipped with front and rear lights. When the machine is turned on using the ignition switch (1), located on the right side of the steering column (**Fig.1**), the front position lights and the tail lights will turn on.

To activate the front working lights, use the icon (2) on the main screen (**Fig.2**).

- i** **N.B.:** when the working headlights are functioning, the icon (2) turns green.
- i** **N.B.:** if you want to turn off the working headlights, press the icon (2), when the working headlights are turned off, the button turns grey again.

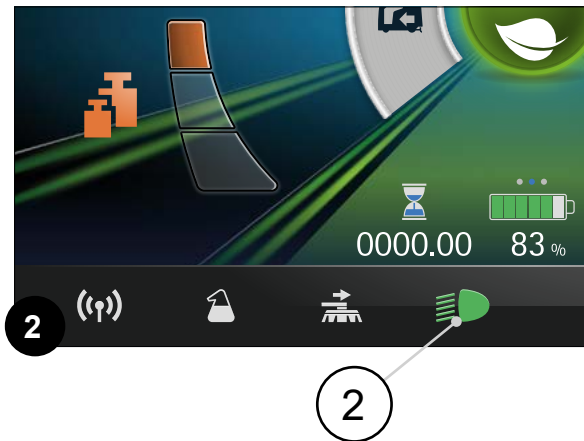
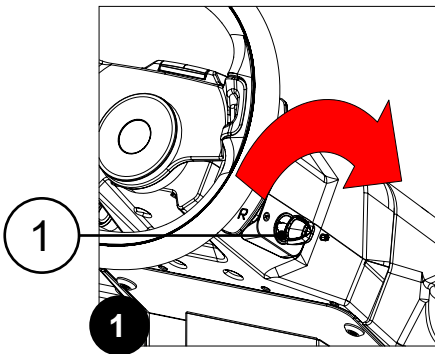

i **N.B.:** to manage the HAZARD LIGHTS function, see [“ATTIVARE O DISATTIVARE LA FUNZIONE HAZARD LIGHTS \(GENERAL - CONFIG\)”](#) on page 36 of the “OPERATOR INTERFACE CONFIGURATION MANUAL” which can be downloaded from the site www.fimap.com

i **N.B.:** If the HAZARD LIGHTS function is active, during use of the machine with the working headlights on, the front and rear LED lights will operate in flashing mode.

ALARM SCREEN

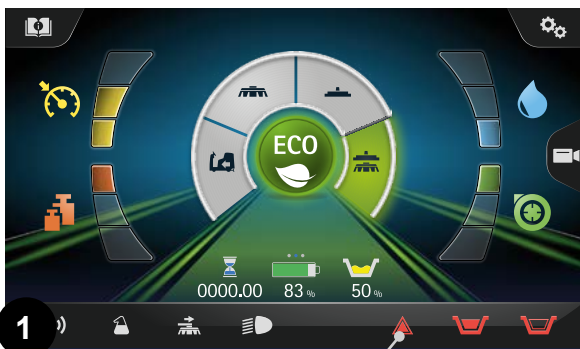

When an error occurs the symbol (1) is displayed in the information field (Fig. 1), it remains visible until the error is resolved.

The “ERROR” window will also be displayed in superimposition” (Fig.2), it describes the following:

- the alarm number (2).
- the group it belongs to (3).
- a brief description (4).

When an error occurs, do as follows:

1. Stop the machine and close the error screen by pressing the OK button on the screen (Fig.2).
2. If the error persists, switch off the machine, wait for at least ten seconds and switch on the machine.
3. If the error persists contact the nearest service centre.

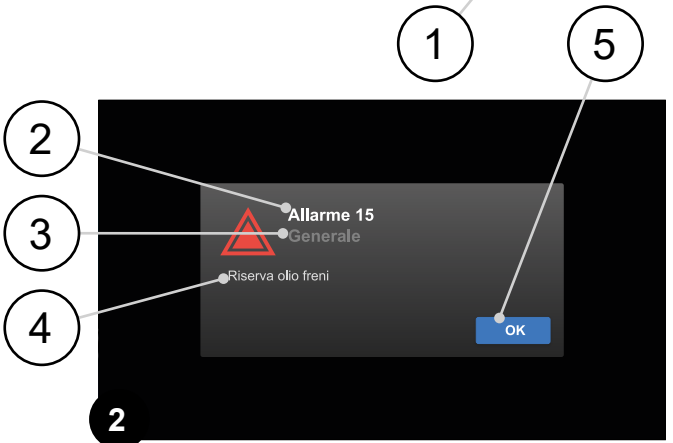

i **N.B.:** the symbol (1) (Fig.1) remains visible until the error is resolved.

i **N.B.:** if the machine is equipped, upon request, with the automatic SOS device, perform the procedure to deliver a request for intervention, see [“SOS DEVICE”](#) on page 98.

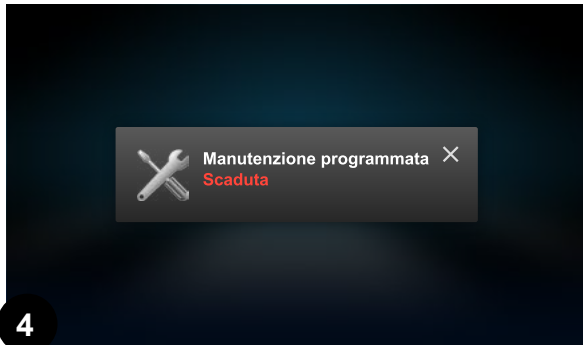
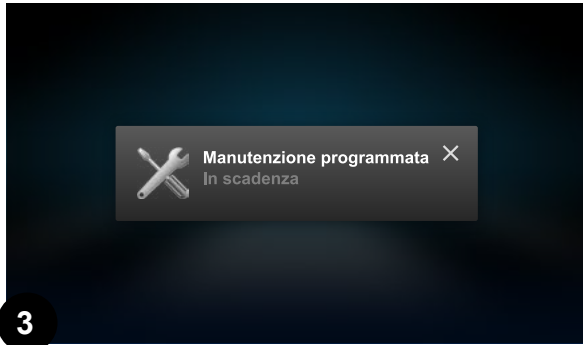

WARNING: if during use of the machine the control display shows the alarm SCHEDULED MAINTENANCE DUE (**Fig.3**), contact your FIMAP service centre of reference or that which is closest to you to arrange the maintenance.

ATTENTION: if during use of the machine the control display shows the alarm SCHEDULED MAINTENANCE OVERDUE (**Fig.4**), contact your FIMAP service centre of reference or that which is closest to you to arrange the maintenance.

N.B.: the scheduled maintenance alarm will remain visible for the period of time identified by the "Service Time" parameter, after which the alarm screen will automatically switch off.

N.B.: if the scheduled maintenance is overdue, each time the machine is switched on, the alarm for this will appear on the control display for the period of time identified by the "Service Time" parameter, after which the alarm screen will automatically switch off.

N.B.: the overdue scheduled maintenance alarm can only be reset by a service technician at the FIMAP service centre.

REAR VIEW CAMERA

The machine is fitted with a rear video camera, which allows you to view the condition of the floor where you have just passed over, and it also helps when reversing, allowing to identify any obstacles.

If you need to view the floor that has just been washed during the work, press the button (1) located on the right-hand side of the main screen (**Fig.1**) or place your finger anywhere on the screen and move it from right to left (**Fig.2**)



1



2

as soon as this has been carried out, the image from the connected camera will be displayed (**Fig.3**).

N.B.: if the rear view camera is not connected correctly, the screen will appear on the control display (**Fig.4**).

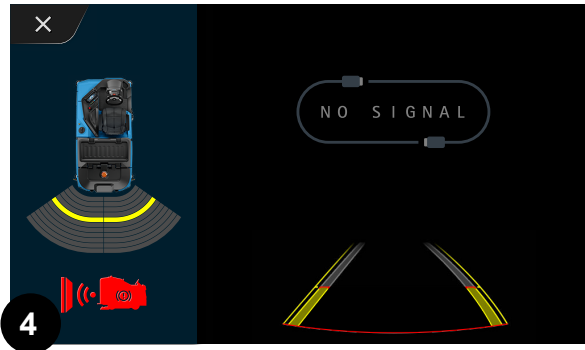

USAGE DATA

When working, it is possible to view the usage data regarding the work being performed. To display the on-board screens, touch any part of the screen and drag your finger from the left to the right (**Fig.1**).

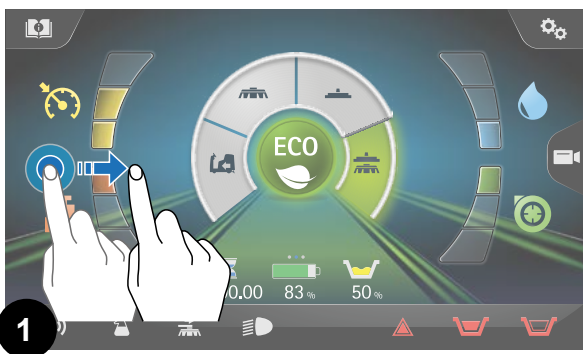

i **N.B.:** the usage data is reset each time the machine is turned off.

The DS selector can be used to select one of the following working modes:

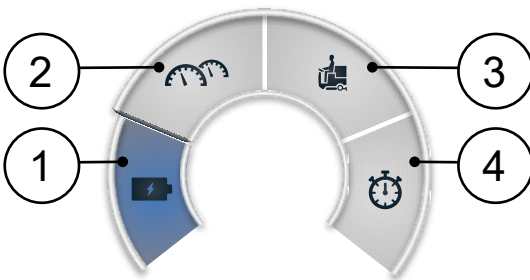

1. Battery data.
2. Telemetry data.
3. Last intervention data.
4. Autonomy data.

i **N.B.:** the centre of the DS selector displays the instantaneous speed of the machine.

i **N.B.:** the text indicator shows the name of the displayed data group.

Battery data group:



- 1.1 Battery state: shows the percentage of charge of the battery box.
- 1.2 Complete charge: indicates the count of charges with a complete cycle performed.
- 1.3 Partial charges: indicates the count of charges with a partial cycle performed.
- 1.4 Total charges: indicates the sum of charges with a continuous cycle and the charges with partial cycle (1.2 + 1.3).

Telemetry data group:



- 2.1
- 2.4

- 2.2
- 2.3

2.1 Traction motors: used to display the instantaneous absorbed current of the traction motors.
 2.2 Brush motors: used to display the instantaneous absorbed current of the suction motors.
 2.3 Total consumption: corresponds to the sum of the three consumptions (2.1 + 2.2 + 2.4).
 2.4 Brush motors: used to display the instantaneous absorbed current of the brush motors.

Last intervention data group:



- 3.1
- 3.4

- 3.2
- 3.3

3.1 Total use: used to display the total usage time of the machine during the last work performed.
 3.2 Cleaned surface: used to display the work surface performed with the last work performed.
 3.3 Utilised water: used to display the quantity of water used with the last work performed.
 3.4 Usage working time: used to display the total usage time of the machine while working during the last work performed.

Autonomy data group:



- 4.1
- 4.4

- 4.2
- 4.3

4.1 Battery residual: used to display the residual charge time calculated based on the program and the settings currently in use.
 4.2 Battery saved: used to display the charge time that is saved if switching to the ECO MODE working program.
 4.3 Water saved: used to display the autonomy time of the detergent solution if switching to the ECO MODE working program.
 4.4 Residual water: used to display the autonomy time of the detergent solution based on the program and the settings currently in use.

TUTORIAL

From the main screen, touching the Tutorial button (1) (Fig.1) will open the TUTORIAL menu.

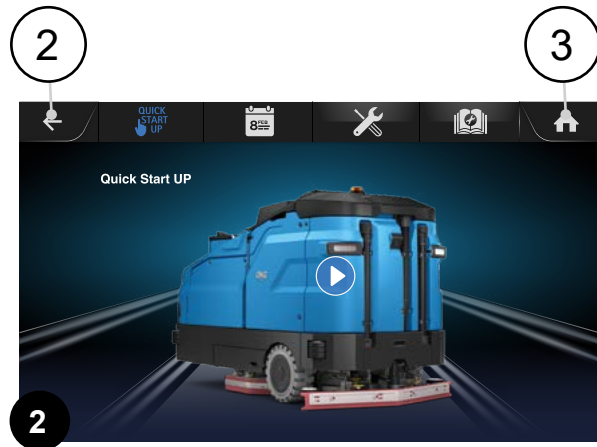
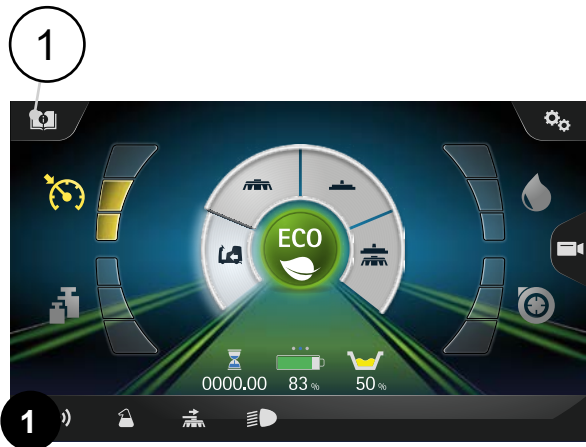

Here, the following screens can be viewed:

	<p>Pressing the button with the icon shown here to the side provides access to the QUICK START UP video tutorials screen, where it is possible to view the machine start up video.</p>
	<p>Pressing the button with the icon shown here to the side provides access to the DAILY MAINTENANCE video tutorials screen, where it is possible to view the videos regarding the daily maintenance to be carried out on the machine.</p>
	<p>Pressing the button with the icon shown here to the side provides access to the EXTRAORDINARY MAINTENANCE video tutorials screen, where it is possible to view the videos regarding the extraordinary maintenance to be carried out on the machine.</p>
	<p>Pressing the button with the icon shown here to the side provides access to the screen dedicated to the USE AND MAINTENANCE MANUAL, where it is possible to view the information on how to use the product correctly, efficiently and safely.</p>
	<p>Pressing the button with the icon shown here to the side provides access to the screen dedicated to the OPERATOR INTERFACE CONFIGURATION MANUAL, where it is possible to view the information regarding how to customise the parameters on the machine's function board.</p>
	<p>Pressing the button with the icon shown here to the side provides access to the screen dedicated to the SPARE PARTS CATALOGUE, where it is possible to view the tool that is required in order to identify and order the machine components that need replacing when subject to the inevitable wear and tear they encounter with use.</p>

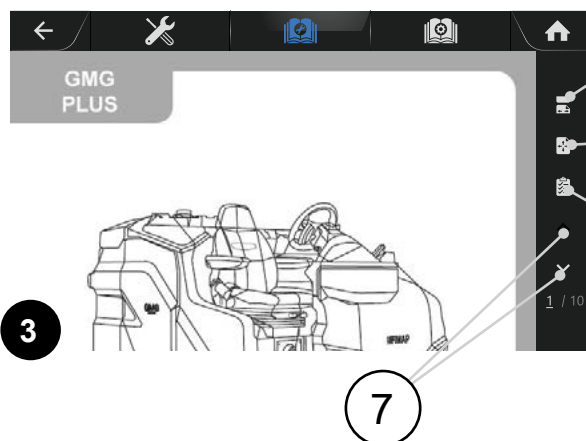

i **N.B.:** when navigating the tutorial menu, all the machine's working functions are disabled, including traction.

i **N.B.:** when navigating the TUTORIAL menu, to return to the previous screen, press the button (2) (Fig.2).

i **N.B.:** when navigating the TUTORIAL menu, to return to the main screen, press the button (3) (Fig.2).

- i** **N.B.:** if it is necessary to view the use and maintenance manual, adapting the display of the page to the width of the screen, press the button (4) (**Fig.3**).
- i** **N.B.:** if it is necessary to view the use and maintenance manual, adapting the display of the entire page inside the screen, press the button (5) (**Fig.3**).
- i** **N.B.:** if it is necessary to view the summary when viewing the use and maintenance manual, press the button (6) (**Fig.3**).
- i** **N.B.:** if it is necessary to scroll the pages of the use and maintenance manual, press the button ^ to go back or press v to go forward with the pages (7) (**Fig.3**).

SIDE BRUSH (COMBINED VERSION)



The combined version of the machine is equipped with two side brushes.

The side brushes are an essential tool when the areas to be cleaned feature shelves or other similar furniture.

The side brushes are able to extend beyond the total width of the machine, thus being able to clean flush with the wall and pass under shelves. In this way the entire room is cleaned in a single passage, and nothing is left behind.

If you need to use the side brushes while working in sweeping mode, press the SIDE BRUSHES CONTROL icon (1). The icon is on the control panel (**Fig.1**).

- i** **N.B.:** when the side brush supports are in the working position, the icon (1) turns green.
- i** **N.B.:** by pressing the icon (1) the side brush holders will begin to move towards the outside of the machine.

- i** **N.B.:** the gearmotors in the side brush supports will start working simultaneously with the gearmotors in the brush head.
- i** **N.B.:** if you want to bring the side brush supports back into the resting position, press the icon (1). When the side brush supports are in the resting position, the icon (1) turns grey.
- i** **N.B.:** if the drive pedal (2) is released when working (**Fig.2**), after a few seconds the side brush holders are automatically positioned in the rest position.
- i** **N.B.:** if the brush head is raised with the side brush holders in the working position, the side brush holders will also move into the rest position.

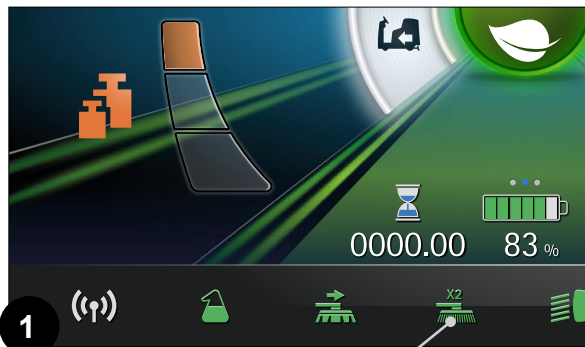

1

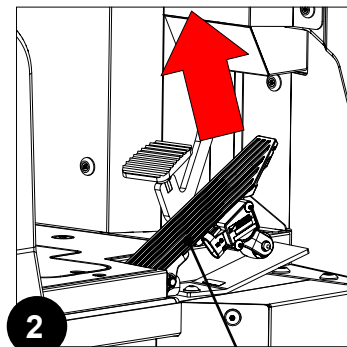

2

OPTIONAL FUNCTIONS

SOS DEVICE

Upon request, the machine can be equipped with an automatic SOS device that allows the user to automatically request technical assistance. When the SOS button is pressed, the machine sends a report directly to the Designated Authorised Workshop (valid only for those who have signed up for one of the service agreements), which will immediately perform a diagnostic check on the machine to determine the type of fault encountered. The SOS device can reduce waiting times for maintenance and machine downtime, thus increasing productivity. To activate the SOS device, do the following:

1. When an anomaly occurs, stop the machine.
2. Open the door (1) covering the SOS button, located near the steering wheel (**Fig.1**).
3. Press the SOS button (2) (**Fig.2**).

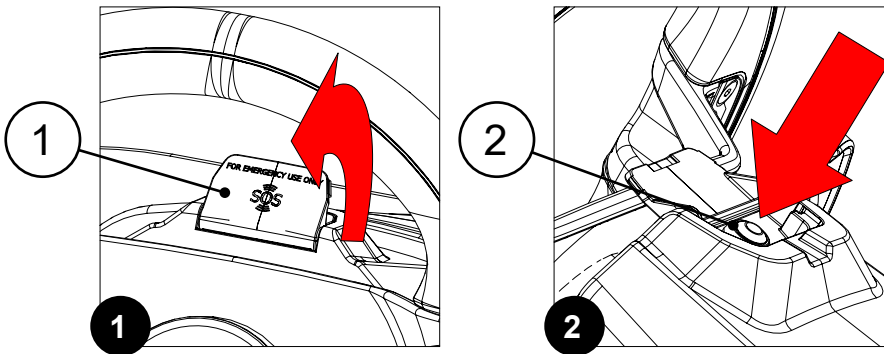

i **N.B.:** In order to activate the SOS device, the machine must be equipped with the automatic fleet management kit (FFM).

i **N.B.:** in order to send a technical assistance request the machine needs to be on and should be in a zone with data traffic coverage.

USB PORT

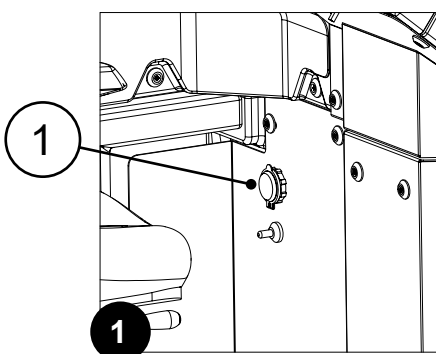

The machine is equipped with two USB ports (1), positioned under the control panel (**Fig.1**), which can be used for recharging electrical devices, such as mobile phones or tablet computers.

BLUE SAFETY LIGHT



On request, the machine can be equipped with a blue safety spotlight above the front dashboard; the purpose of this light is to warn pedestrians of the approach of the machine. The device is suitable for both indoor and outdoor applications. It is ideal for use inside warehouses or on forecourts, where architectural structures, furniture or storage racks can prevent full visibility of the moving machine.

i **N.B.:** The blue light safety system increases the overall level of safety by making the vehicle visible when in motion.

i **N.B.:** this system makes it possible to reduce risks in areas where vehicles and people cross over when the machine is in motion.

i **N.B.:** a blue light is projected onto the ground, warning of the machine's approach and signalling in advance that it will be passing through the area.

i **N.B.:** the blue safety light is connected to the machine main switch.

RECOVERY TANK SPRAY CLEANING GUN



Upon request, the machine can be equipped with a recovery tank spray cleaning gun kit. The recovery tank spray cleaning gun kit allows the user to utilise the water in the solution tank to clean the recovery tank, thus saving time and ensuring greater environmental sustainability. To use the kit, do the following:

1. Take the machine to the maintenance area.

! **WARNING:** the place designated for this operation must comply with current regulations concerning safety at work and current environmental protection regulations.

2. Stop the machine.
3. Activate the "SERVICE" function, see ["SERVICE FUNCTION" on page 86.](#)
4. Activate the recovery tank cleaning spray gun kit switch (1) located on the control panel (**Fig.1**).

i **N.B.:** when the kit is functioning, the dedicated screen appears on the control display (**Fig.2**) and the LED in the switch (1) is on (**Fig.1**).

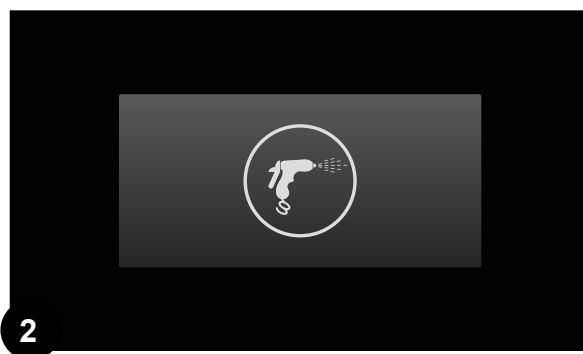
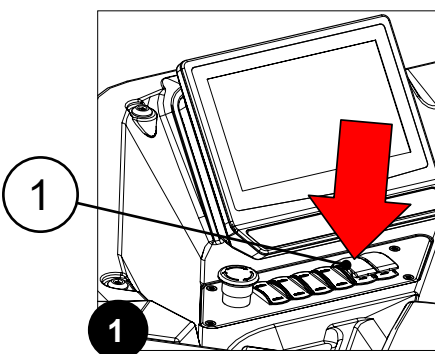

- i** **N.B.:** if you want to turn the kit off, press the switch (1). When the system is deactivated, the LED in the switch (1) will be off.
- i** **N.B.:** when the kit is deactivated the screen (**Fig. 2**) will no longer be visible on the control display.
- i** **N.B.:** the kit is only in function when the machine is stopped and the solution tank is not empty.
- i** **N.B.:** with the kit active, the traction and work functions are deactivated.
- i** **CAUTION:** it is recommended to wear the appropriate PPE (Personal Protective Equipment), suitable for the work to be carried out.

5. Get off the machine.
6. Open the lateral door (2) (**Fig.3**)
7. Remove the recovery tank spray cleaning gun (3) (**Fig.4**).
8. To clean the recovery tank, perform the procedure described in the [“DRAINING THE RECOVERY TANK” on page 121.](#)
9. Activate the solution jet by pressing the lever in the tank cleaning accessory. Make sure the jet is pointing into the tank before pressing the lever.

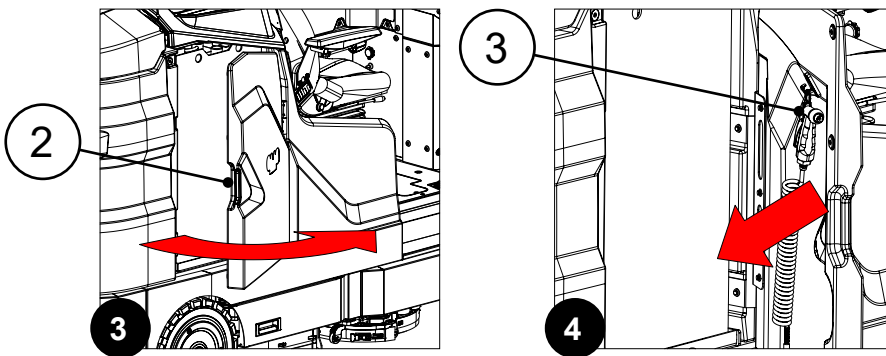

- i** **N.B.:** To adjust the solution jet from the tank cleaning accessory, turn the knob (4) on the accessory itself (**Fig.5**).
- i** **N.B.:** To adjust the intensity of the solution jet from the tank cleaning accessory, turn the knob (5) on the accessory itself (**Fig.6**).
- i** **N.B.:** To stop the solution jet, use the lever (6) on the tank cleaning accessory (**Fig.7**).

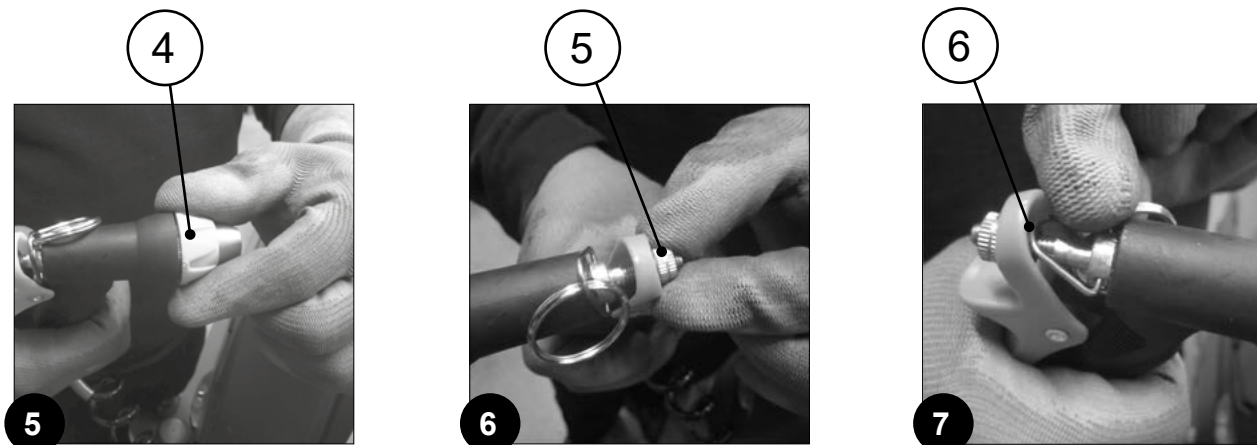

LIQUID VACUUM WAND



Upon request, the machine can be equipped with a liquid vacuum wand kit, which can be used to dry areas that are difficult to reach with the machine itself.

i **N.B.:** the rubber blade on the tip of the nozzle perfectly dries the surface to which is applied thanks to the machine's highly efficient vacuum system.

To use the kit, do the following:

1. Take the machine to the maintenance area.

! **WARNING:** the place designated for this operation must comply with current regulations concerning safety at work and current environmental protection regulations.

2. Stop the machine.
3. Activate the "SERVICE" function, see ["SERVICE FUNCTION" on page 86.](#)
4. Activate the liquid vacuum wand kit by pressing the switch (1) on the control panel (**Fig.1**).

! **CAUTION:** it is recommended to wear the appropriate PPE (Personal Protective Equipment), suitable for the work to be carried out.

5. Get off the machine.
6. Remove all the kit components from the storage compartment in the battery box lid (**Fig.**).
7. Assemble the steel extension tube (**Fig.2**).
8. Insert the vacuum brush into the extension tube (**Fig.3**).

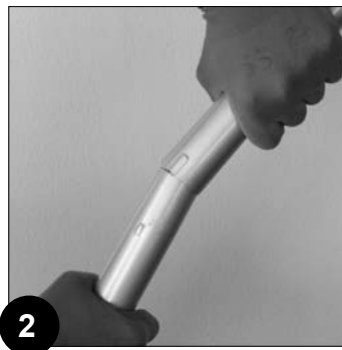
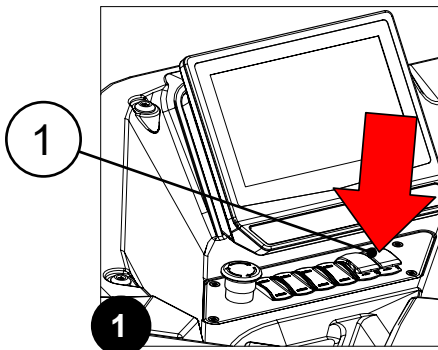

9. Connect the vacuum tube to the extension tube (**Fig.4**).
10. Remove the squeegee vacuum tube (2) from the sleeve (3) in the squeegee (**Fig.5**).
11. Connect the suction hose contained in the vacuum wand kit to the squeegee vacuum pipe.

i **N.B.:** when the kit is functioning, the dedicated screen appears on the control display (**Fig.6**) and the LED in the switch (1) is on (**Fig.1**).

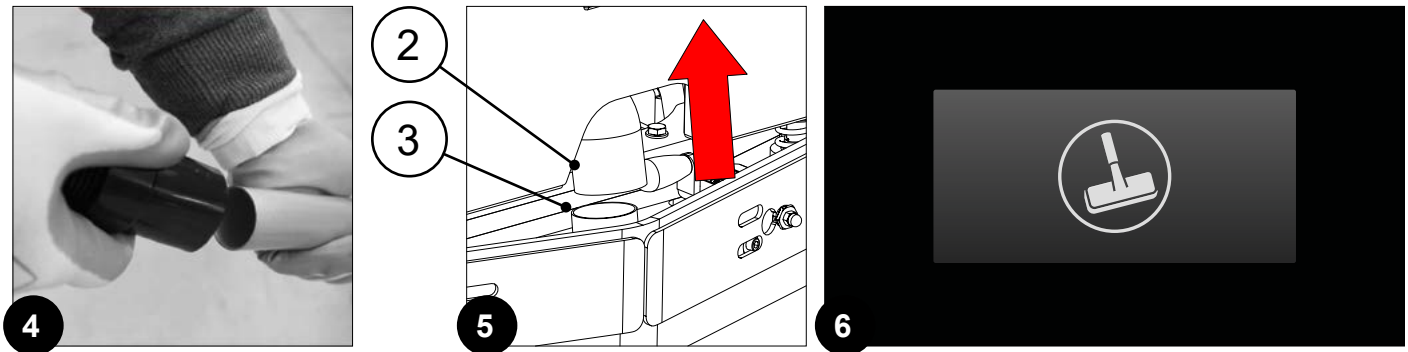

i **N.B.:** if you want to turn the kit off, press the switch (1). When the system is deactivated, the LED in the switch (1) will be off.

i **N.B.:** when the function is deactivated the screen (**Fig. 6**) will no longer be visible on the control display.

i **N.B.:** the kit is only in function when the machine is stopped and the recovery tank is not full.

i **N.B.:** when the vacuum kit is in function, the suction motor is powered at maximum.

i **N.B.:** with the kit active, the traction and work functions are deactivated.

! **WARNING:** Never collect solid substances, such as dust, cigarette butts, paper, etc.

! **WARNING:** Never collect gases, explosive/inflammable liquids or powders, nor acids and solvents! These include gasoline, paint thinners and fuel oil (which, when mixed with the vacuum air, can form explosive vapours or mixtures), and also non-diluted acids and solvents, acetones, aluminium and magnesium powders. These substances may also corrode the materials used to construct the machine.

! **WARNING:** if the machine is used in dangerous areas (e.g. petrol stations), the relative safety standards must be observed. It is forbidden to use the machine in environments with a potentially explosive atmosphere.

12. Carry out the vacuuming operations.

13. When the work is finished, remove the kit and place it in the storage compartment.

FFM - TAG INSERTION



Upon request, the machine can be equipped with an integrated system that allows the machine fleet to be fully monitored. In order to check that the machines are carrying out the planned work activities correctly, one would always have to be present at the work site. The automatic fleet management system (FFM) allows the status of each machine, the workload, the consumption values, and the maintenance requirements to be constantly monitored, thus ensuring improved fleet management and reduced costs. The FFM system is connected to the data network, which in turn transfers all the information that the user wants to know about each machine in their fleet, in real time.

To activate automatic fleet management data logging, do the following:

1. Sit on the driver's seat.
2. Insert the key (1) into the slot (2) on the right side of the column (**Fig.1**).
3. Turn on the machine and turn the key (1) a quarter turn clockwise (**Fig.2**).

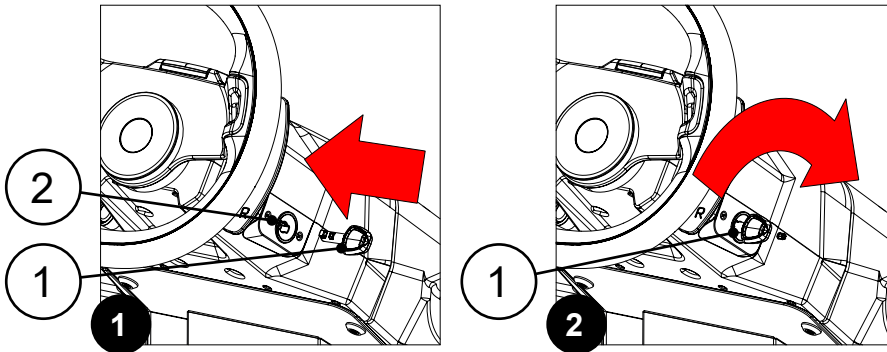

i **N.B.:** If the key just inserted is not equipped with a TAG, the alarm 10 will appear on the control display (**Fig.3**).

i **N.B.:** If the owner of the TAG just inserted is not enabled to use it, the AL_11 alarm will appear on the control display (**Fig.4**).

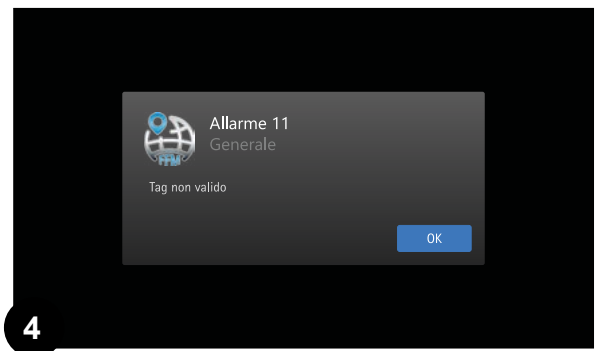
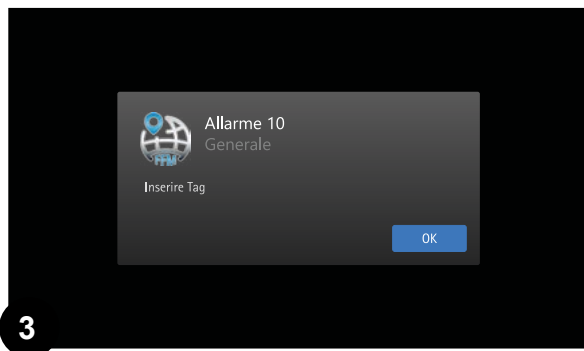

4. The machine is now in the transfer mode.
5. To begin the work, see [“STARTING WORK” on page 71](#).

SIDE BRUSH (DISCOID SCRUBBING VERSIONS)



The machine can be equipped with a side brush head upon request.

The side brush head is an essential tool when the areas to be cleaned feature shelves or other similar furniture.

The side brush moves 20 cm sideways, thus cleaning along walls and under shelves. In this way the entire room is cleaned in a single passage, and nothing is left behind.

If you need to use the side brush while working in scrubbing machine mode, press the SIDE BRUSH CONTROL icon (1). The icon is on the control display (**Fig.1**).

- i** **N.B.:** when the side brush head is in the working position, the icon (1) turns green.
- i** **N.B.:** when the icon (1) is pressed, the side brush head will start to move towards the outside of the machine.
- i** **N.B.:** the gearmotor in the side brush head will start to work at the same time as the gearmotors in the brush head.
- i** **N.B.:** the solenoid valve in the side brush head will start to dispense detergent solution together with the solenoid valve in the brush head.
- i** **N.B.:** if you want to bring the side brush head back to its resting position, press the icon (1). When the side brush head body is in its resting position, the icon (1) turns grey.
- i** **N.B.:** if the drive pedal (2) is released when working (**Fig.2**), after a few seconds the side brush head is automatically positioned in the rest position.
- i** **N.B.:** If the brush head is raised when the side brush head is in the working position, the side brush head will also be moved into the resting position.

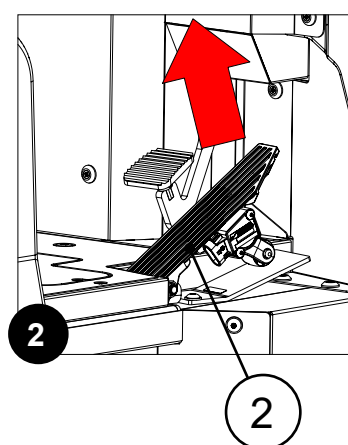
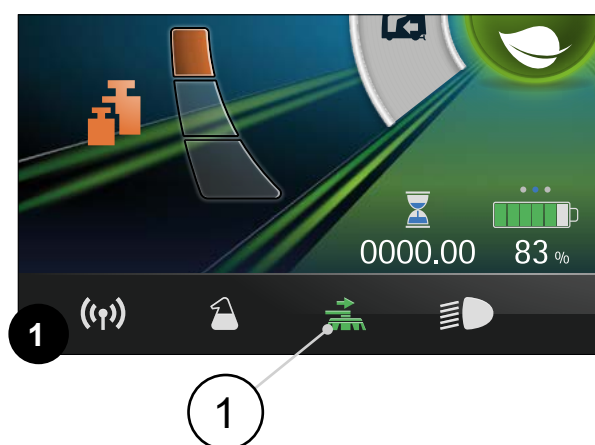

- i** **N.B.:** to activate or deactivate the optional side brush function, see [“ATTIVARE O DISATTIVARE LA FUNZIONE SPAZZOLA LATERALE \(GENERAL - CONFIG\)”](#) on page 35 of the “OPERATOR INTERFACE CONFIGURATION MANUAL” which can be downloaded from the site www.fimap.com

SIDE BRUSH (CYLINDRICAL SCRUBBING VERSION)



The machine can be equipped with two side brushes upon request.

The side brushes are an essential tool when the areas to be cleaned feature shelves or other similar furniture.

The side brushes are able to extend beyond the total width of the machine, thus being able to clean flush with the wall and pass under shelves. In this way the entire room is cleaned in a single passage, and nothing is left behind.

If you need to use the side brushes while working in scrubbing-drying mode, press the SIDE BRUSHES CONTROL icon (1). The icon is on the control panel (**Fig.1**).

- i** **N.B.:** when the side brush supports are in the working position, the icon (1) turns green.
- i** **N.B.:** by pressing the icon (1) the side brush holders will begin to move towards the outside of the machine.

- i** **N.B.:** the gearmotors in the side brush supports will start working simultaneously with the gearmotors in the brush head.
- i** **N.B.:** if you want to bring the side brush supports back into the resting position, press the icon (1). When the side brush supports are in the resting position, the icon (1) turns grey.
- i** **N.B.:** if the drive pedal (2) is released when working (**Fig.2**), after a few seconds the side brush holders are automatically positioned in the rest position.
- i** **N.B.:** if the brush head is raised with the side brush holders in the working position, the side brush holders will also move into the rest position.

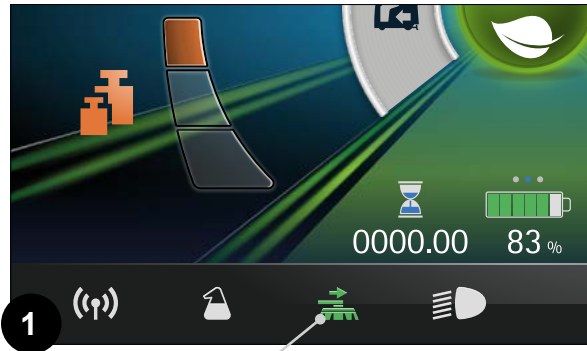

1

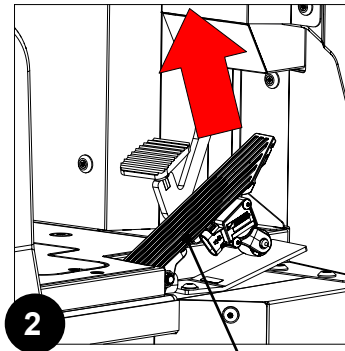

2

- i** **N.B.:** to activate or deactivate the optional side brushes function, see [“ATTIVARE O DISATTIVARE LA FUNZIONE SPAZZOLA LATERALE \(GENERAL - CONFIG\)”](#) on page 35 of the “OPERATOR INTERFACE CONFIGURATION MANUAL” which can be downloaded from the site www.fimap.com

FLR - CONTINUOUS RECYCLING SYSTEM

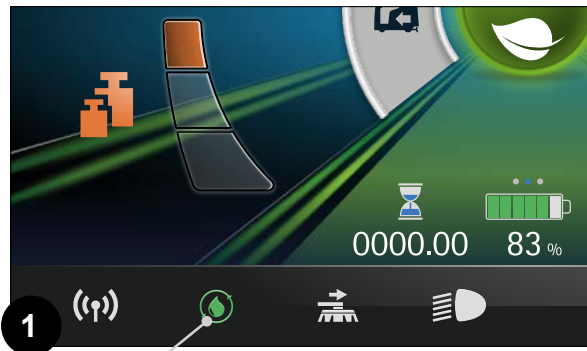







1

Upon request, the machine can be equipped with a continuous detergent solution recycling system.

- i** **N.B.:** The continuous detergent solution recycling system is a system that filters and cleans the detergent solution collected from the squeegee, thus making it available again for use.
- i** **N.B.:** the use of the continuous detergent solution recycling system results in decreased water and detergent use, thus increasing safety for the operator, who comes into contact with the chemical products less frequently, and reducing costs.
- i** **N.B.:** reusing the water increases the working autonomy, allows for more sq.m. to be cleaned using the same amount of resources, for a reduction in detergent solution consumption per intervention of up to 66% (savings calculated on a triple recycling cycle), and increases productivity up to 70%, as the number of stops required for emptying and filling the tanks are considerably reduced.
- i** **N.B.:** the continuous recycling system is ideal for areas that are cleaned frequently and don't get very dirty.



If the machine you are using is equipped with the detergent solution recycling system, once the machine has been turned on, press the RECYCLING SYSTEM CONTROL icon (1) on the control display (**Fig.1**).

-  **N.B.:** when the recycling system is functioning, the icon (1) turns green.
-  **N.B.:** if you want to turn the recycling system off, press the switch (1), when the system is deactivated, the icon turns grey.
-  **N.B.:** at the end of each work cycle, perform all the procedures listed in paragraph [“DAILY MAINTENANCE”](#) on page 110.
-  **N.B.:** the continuous recycling system includes a solenoid valve for the solution tank (referred to herein as ELE-01) and a solenoid valve for the recovery tank (referred to herein as ELE-02).
-  **N.B.:** with the continuous recycling system, the solenoid valve present in the scrubbing brush head is powered together with solenoid valve ELE-01 or ELE-02, based on the cases indicated below.
-  **N.B.:** with the continuous recycling system off, or until the solution tank is empty, the machine's electrical system will power solenoid valve ELE-01.
-  **N.B.:** with the continuous recycling system enabled, or with the solution tank empty, the machine's electrical system will power solenoid valve ELE-02.

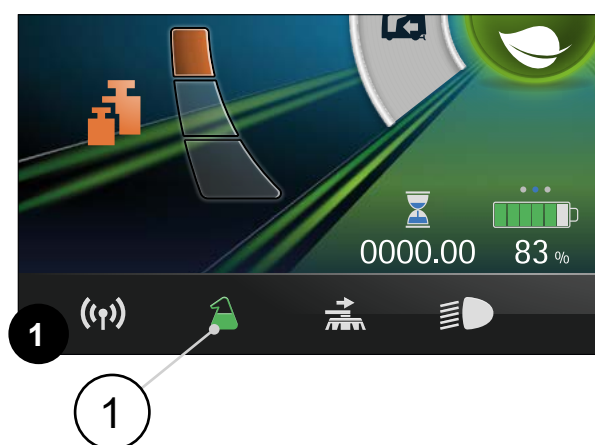



FSS - AUTOMATIC DETERGENT DOSING SYSTEM



Upon request, the machine can be equipped with an automatic detergent dosing system.

-  **N.B.:** with the automatic dosing system installed on the machine, the user can be sure that they're dispensing the right amount of solution based on the actual needs. For example, heavy duty cleaning requires more water and detergent than maintenance cleaning, for which the dirt typically is non very stubborn.
-  **N.B.:** One of the greatest strengths of the machine's built-in automatic dosing system is its ability to save water whenever possible, and to avoid using more detergent than necessary.

If the machine being used has an automatic dosing system, after turning on the machine press the AUTOMATIC DOSING SYSTEM CONTROL icon (1), on the control display (**Fig.1**).

-  **N.B.:** when the automatic dosing system is functioning, the icon (1) turns green.
-  **N.B.:** if you want to turn the automatic dosing system off, press the icon (1), when the system is deactivated, the icon (1) is deactivated.
-  **N.B.:** at the end of each work cycle, perform all the procedures listed in paragraph [“DAILY MAINTENANCE”](#) on page 110.
-  **N.B.:** when the automatic dosing system is in function, the chemical dosing pump is powered together with the water pump.
-  **N.B.:** to change the percentage of chemical product present in the detergent solution, see [“MODIFICA QUANTITÀ DI CHIMICO NEL SISTEMA DOSAGGIO AUTOMATICO DETERGENTE \(SETTAGGI - DETERGENTE\)”](#) on page 19 of the “OPERATOR INTERFACE CONFIGURATION MANUAL” which can be downloaded from the site www.fimap.com

AT THE END OF THE WORK

At the end of the work, and before carrying out any type of maintenance, perform the following operations:

1. Activate the TRANSFER working mode, see [“DS SELECTOR \(DRIVE SELECT\)” on page 70](#).
2. Take the appliance to the dedicated dirty water drainage area.



WARNING: the place designated for this operation must comply with current regulations concerning safety at work and current environmental protection regulations.



CAUTION: it is recommended to wear the appropriate PPE (Personal Protective Equipment), suitable for the work to be carried out.

3. Make sure the machine is in a safe condition, see [“MACHINE SAFETY” on page 35](#).
4. Perform all the daily maintenance procedures on the machine, see [“DAILY MAINTENANCE” on page 110](#).
5. Once the daily maintenance operations are complete, take the machine to the designated storage location.



ATTENTION: Park the machine in an enclosed place, on a flat surface; near the machine there must be no objects that could either damage it, or be damaged through contact with it.

6. Secure the machine, see [“MACHINE SAFETY” on page 35](#).

MAINTENANCE PLAN



The importance of machine maintenance should not be underestimated.

By ensuring the machine is inspected regularly, we can replace all parts that become worn in a timely manner.

In addition, we can also recognise faults quickly, thus increasing the useful life of our machine.

i **N.B.:** Through its network of certified service centres, FIMAP proposes a range of special offers on maintenance services, such as those available in automotive workshops, see <https://www.fimap.com/it/fimap/22/manutenzione-e-riparazione.html>.

First, it is important to understand the difference between the various types of maintenance:

- routine maintenance is an activity designed to keep the machine in good working order.
- extraordinary maintenance regards work carried out to implement substantial updates on the machine.

i **N.B.:** the primary purpose of routine maintenance is to maintain the performance of the machine's various functions, checking for any worn or faulty elements. A fault that is not fixed or an excessively worn part could cause damage to the machine or injure persons in the vicinity.

i **N.B.:** The main purpose of extraordinary maintenance is to replace any worn or defective elements.

i **N.B.:** In addition, maintenance enables the operator to use the machine in a safer manner, in the knowledge that the risk of unforeseen events has been reduced as far as possible.

i **N.B.:** The use and maintenance manual contains all the procedures to be carried out during routine maintenance of the machine. By following these instructions, even individuals with no particular expertise in this area can check the machine and replace any parts necessary, taking a DIY approach. However, it is essential to remember the importance of entrusting the work to genuine professionals. An experienced specialist may notice details that could escape the notice of a less observant and expert eye.

i **N.B.:** A dilemma may arise during maintenance: which spare parts are best? FIMAP supplies original spare parts which are exactly identical to the parts on a given machine that need replacing; these are the best choice because they are durable and long-lasting, and help to maintain the performance of the machine.

i **N.B.:** FIMAP service centres use these spare parts; in an unauthorised workshop, however, we recommend explicitly asking the technicians to use only these genuine FIMAP products. Using official spare parts extends the longevity of your machine.

DAILY MAINTENANCE

MACHINE COMPONENTS	PROCEDURE
Vacuum group	At the end of every work day, clean the squeegee, see “CLEANING THE SQUEEGEE” on page 116.
	At the end of every work day, clean the squeegee vacuum tube, see “CLEANING THE SQUEEGEE VACUUM HOSE” on page 117.
	Clean the collection filter tray in the recovery tank at the end of each work day. See “CLEANING THE COLLECTION FILTER TRAY” on page 119.
	Clean the wave protection tray in the recovery tank at the end of each work day. See “CLEANING THE WAVE PROTECTION TRAY” on page 120.
	At the end of every work day, clean the side brush head squeegee, see “CLEANING OF SIDE BRUSH HEAD SQUEEGEE (DISCOID SCRUBBING VERSION)” on page 130.
	At the end of every work day, clean the debris hopper vacuum filter, see “CLEANING THE DEBRIS HOPPER VACUUM FILTER (COMBINED VERSION)” on page 136.
Scrubbing system; sweeping	Clean the brushes in the brush head at the end of each work day, see “CLEANING OF BRUSH HEAD DRIVE BRUSH - DISC (DISCOID SCRUBBING VERSIONS)” on page 126.
	Clean the rubber blades of the brush head splash guard at the end of each work day, see “CLEANING OF BRUSH HEAD SIDE SPLASH GUARD (DISCOID SCRUBBING VERSION)” on page 128.
	Clean the brushes in the brush head at the end of each work day, see “CLEANING OF BRUSH HEAD BRUSH (CYLINDRICAL SCRUBBING VERSIONS)” on page 131.
	Clean the rubber blades of the brush head splash guard at the end of each work day, see “CLEANING OF BRUSH HEAD SIDE SPLASH GUARD (CYLINDRICAL SCRUBBING VERSION)” on page 132.
	Clean the brushes in the sweeping brush head at the end of each work day, see “CLEANING THE BRUSH HEAD BRUSHES (COMBINED VERSION)” on page 135.
	Clean the brush in the brush head at the end of each work day, see “CLEANING OF SIDE BRUSH HEAD DRIVE BRUSH - DISC (DISCOID SCRUBBING VERSION)” on page 128.
	Clean the rubber blade of the side brush head splash guard at the end of each work day, see “CLEANING OF SIDE BRUSH HEAD SPLASH GUARD (DISCOID SCRUBBING VERSION)” on page 129.
	Clean the side sweeping brushes at the end of each work day, see “CLEANING THE SIDE BRUSH (CYLINDRICAL - COMBINED SCRUBBING VERSION)” on page 133.
Recovery tank	Empty the recovery tank at the end of each work day, see “DRAINING THE RECOVERY TANK” on page 121.
	At the end of each work day, empty the recovery tank and clean inside the recovery tank, see “DRAINING THE RECOVERY TANK” on page 121.
	At the end of each work day, after emptying and cleaning the recovery tank, clean the detergent solution recycling system filters. See the “CLEANING THE FILTER ON THE DETERGENT SOLUTION RECYCLING SYSTEM (FLR VERSION)” on page 125.
Solution tank	Empty the solution tank at the end of each work day, see “EMPTYING THE SOLUTION TANK” on page 123.
	At the end of each work day, after emptying the solution tank, clean inside the solution tank, see “EMPTYING THE SOLUTION TANK” on page 123.
Battery-powered supply system	For the maintenance of the batteries utilised, follow the instructions contained in the document provided by the battery manufacturer.

WEEKLY MAINTENANCE

MACHINE COMPONENTS	PROCEDURE
Machine water system	Every week, clean the filter of the machine water system, see “CLEANING THE WATER SYSTEM FILTER” on page 123.
	Check the integrity of the machine's water system filter each week. If it needs to be replaced, contact your FIMAP service centre of reference or the one closest to you.
Automatic chemical detergent management system	Clean the automatic chemical detergent management system filter every week, see “CLEANING THE FILTER ON THE AUTOMATIC CHEMICAL DETERGENT MANAGEMENT SYSTEM (FSS VERSION)” on page 124.
	Check the condition of the automatic chemical detergent management system filter each week. If it needs to be replaced, contact your FIMAP service centre of reference or the one closest to you.
Vacuum group	Check the integrity of the rubber blades on the squeegee, if replacement is necessary see “REPLACING THE SQUEEGEE RUBBER BLADES” on page 146.
	Check the condition of the squeegee vacuum tube every week. If it needs to be replaced, contact your FIMAP service centre of reference or the one closest to you.
	Check the condition of the recovery tank wave protection tray every week. If it needs to be replaced, contact your FIMAP service centre of reference or the one closest to you.
	Check the condition of the recovery tank collection filter each week. If it needs to be replaced, contact your FIMAP service centre of reference or the one closest to you.
	Check the integrity of the rubber blades on the side brush head brush squeegee, if replacement is necessary see “REPLACEMENT OF SIDE BRUSH HEAD SQUEEGEE RUBBER BLADES (DISCOID SCRUBBING VERSION)” on page 145.
	Check the condition of the squeegee vacuum tube on the side brush head brush every week. If it needs to be replaced, contact your FIMAP service centre of reference or the one closest to you.
	Check the condition of the debris hopper vacuum filter every week. If it needs to be replaced, contact your FIMAP service centre of reference or the one closest to you.
Scrubbing system; sweeping	Check the integrity of the brushes on the brush head body every week. If they need to be replaced, see “REPLACEMENT OF BRUSH HEAD DRIVE BRUSHES OR DISCS (DISCOID SCRUBBING VERSION)” on page 141.
	Check the integrity of the rubber blades of the brush head splash guard every week. If they need to be replaced, see “REPLACEMENT OF BRUSH HEAD SIDE SPLASH GUARD (DISCOID SCRUBBING VERSION)” on page 143.
	Check the integrity of the brush in the side brush head every week. If it needs to be replaced, see the “REPLACEMENT OF SIDE BRUSH HEAD DRIVE BRUSH OR DISCS (DISCOID SCRUBBING VERSION)” on page 144.
	Check the integrity of the rubber blade of the brush head splash guard every week. If it needs to be replaced, see “REPLACEMENT OF SIDE BRUSH HEAD SPLASH-GUARD RUBBER BLADE (DISCOID SCRUBBING VERSION)” on page 144.
	Check the integrity of the brushes on the brush head body every week. If they need to be replaced, see “REPLACING THE BRUSH HEAD BRUSHES (CYLINDRICAL SCRUBBING VERSION)” on page 148.
	Check the integrity of the rubber blades of the brush head splash guard every week. If they need to be replaced, see “REPLACEMENT OF BRUSH HEAD SIDE SPLASH GUARD (CYLINDRICAL VERSION)” on page 239.
	Check the integrity of the brush in the side brush head every week. If it needs to be replaced, see “REPLACEMENT OF THE SIDE BRUSH (CYLINDRICAL-COMBINED SCRUBBING VERSION)” on page 150.
	Check the integrity of the brushes on the brush head body every week. If they need to be replaced, see “REPLACING THE SWEEPING BRUSH HEAD BRUSHES (COMBINED VERSION)” on page 151.

MACHINE COMPONENTS	PROCEDURE
Recovery tank	Check the condition of the recovery tank drain pipe every week. If it needs to be replaced, contact your FIMAP service centre of reference or the one closest to you.
	Each week, after having drained and cleaned the recovery tank, check the condition of the detergent solution recycling system filters. If they need to be replaced, contact your FIMAP service centre of reference or the one closest to you.
Solution tank	Check the condition of the solution tank drain pipe every week. If it needs to be replaced, contact your FIMAP service centre of reference or the one closest to you.
	Each week, after having drained and cleaned the recovery tank, check the integrity of the machine's water system filter. If it needs to be replaced, contact your FIMAP service centre of reference or the one closest to you.
Battery-powered supply system	For the maintenance of the batteries utilised, follow the instructions contained in the document provided by the battery manufacturer.

MONTHLY MAINTENANCE

MACHINE COMPONENTS	PROCEDURE
Vacuum group	Check the correct levelling of the rubber blades in the squeegee every month, if they need to be adjusted see "ADJUSTING THE SQUEEGEE RUBBER BLADES" on page 153.
	Check the wear of the rubber dust guards in the debris hopper every month. If necessary to replace, contact your FIMAP service centre of reference or the one closest to you.
Scrubbing system; sweeping	Check the correct levelling of the rubber blades in the scrubbing brush head every month, if they need to be adjusted see "ADJUSTMENT OF BRUSH HEAD SIDE SPLASH GUARD (DISCOID SCRUBBING VERSION)" on page 156.
	Check the correct levelling of the rubber blades in the scrubbing brush head every month, if they need to be adjusted see "ADJUSTMENT OF BRUSH HEAD SIDE SPLASH GUARD (CYLINDRICAL SCRUBBING VERSION)" on page 157.
	Check the wear of the rubber dust guards in the sweeping brush head every month. If necessary to replace, contact your FIMAP service centre of reference or the one closest to you.
Battery-powered supply system	For the maintenance of the batteries utilised, follow the instructions contained in the document provided by the battery manufacturer.

MAINTENANCE PRIOR TO EXTENDED PERIODS OF DOWNTIME

MACHINE COMPONENTS	PROCEDURE
Vacuum group	Clean the squeegee before extended periods of machine downtime, see “CLEANING THE SQUEEGEE” on page 116 .
	Clean the side brush head squeegee before extended periods of machine downtime, see “CLEANING OF SIDE BRUSH HEAD SQUEEGEE (DISCOID SCRUBBING VERSION)” on page 130 .
	Clean the vacuum tube before extended periods of machine downtime, see “CLEANING THE SQUEEGEE VACUUM HOSE” on page 117 .
	Clean the wave protection tray in the recovery tank before extended periods of machine downtime, see “CLEANING THE WAVE PROTECTION TRAY” on page 120 .
	Clean the collection filter in the recovery tank before extended periods of machine downtime, see “CLEANING THE COLLECTION FILTER TRAY” on page 119 .
	Clean the suction filter in the recovery tank before extended periods of machine downtime, see “CLEANING THE DEBRIS HOPPER VACUUM FILTER (COMBINED VERSION)” on page 136 .
Scrubbing system; sweeping	Clean the brushes in the brush head before extended periods of machine downtime, see “CLEANING OF BRUSH HEAD DRIVE BRUSH - DISC (DISCOID SCRUBBING VERSIONS)” on page 126 .
	Clean the rubber blades of the brush head splash guard before extended periods of machine downtime, see “CLEANING OF BRUSH HEAD SIDE SPLASH GUARD (DISCOID SCRUBBING VERSION)” on page 128 .
	Clean the brush in the side brush head before extended periods of machine downtime, see “CLEANING OF SIDE BRUSH HEAD DRIVE BRUSH - DISC (DISCOID SCRUBBING VERSION)” on page 128 .
	Clean the rubber blade of the side brush head splash guard before extended periods of machine downtime, see “CLEANING OF SIDE BRUSH HEAD SPLASH GUARD (DISCOID SCRUBBING VERSION)” on page 129 .
	Clean the brushes in the brush head before extended periods of machine downtime, see “CLEANING OF BRUSH HEAD BRUSH (CYLINDRICAL SCRUBBING VERSIONS)” on page 131 .
	Clean the rubber blades of the brush head splash guard before extended periods of machine downtime, see “CLEANING OF BRUSH HEAD SIDE SPLASH GUARD (CYLINDRICAL SCRUBBING VERSION)” on page 132 .
	Clean the brush in the side brush head before extended periods of machine downtime, see “CLEANING THE SIDE BRUSH (CYLINDRICAL - COMBINED SCRUBBING VERSION)” on page 133 .
	Clean the debris hopper present in the brush head before extended periods of machine downtime, see “CLEANING THE DEBRIS HOPPER (CYLINDRICAL SCRUBBING VERSION)” on page 132 .
	Clean the brushes in the sweeping brush head before extended periods of machine downtime, see “CLEANING THE BRUSH HEAD BRUSHES (COMBINED VERSION)” on page 135 .
Clean the debris hopper in the sweeping group before extended periods of machine downtime, see “CLEANING THE DEBRIS HOPPER (COMBINED VERSION)” on page 137 .	
Recovery tank	Empty the recovery tank before extended periods of machine downtime see “DRAINING THE RECOVERY TANK” on page 121 .
	After emptying the recovery tank, clean its interior before extended periods of machine downtime, see “DRAINING THE RECOVERY TANK” on page 121 .
	Before extended periods of machine downtime, after having emptied and cleaned the recovery tank, clean the detergent solution recycling system filters, see “CLEANING THE FILTER ON THE DETERGENT SOLUTION RECYCLING SYSTEM (FLR VERSION)” on page 125 .

MACHINE COMPONENTS	PROCEDURE
Solution tank	Empty the solution tank before extended periods of machine downtime, see “EMPTYING THE SOLUTION TANK” on page 123.
	After emptying the solution tank, clean its interior before extended periods of machine downtime, see “EMPTYING THE SOLUTION TANK” on page 123.
Machine water system	Clean the machine water system filter before extended periods of machine downtime, see “CLEANING THE WATER SYSTEM FILTER” on page 123.
Automatic chemical detergent management system	Clean the automatic chemical detergent management system filter before extended periods of machine downtime, see “CLEANING THE FILTER ON THE AUTOMATIC CHEMICAL DETERGENT MANAGEMENT SYSTEM (FSS VERSION)” on page 124.
	Empty the detergent tank on the automatic chemical detergent management system before extended periods of machine downtime, see “EMPTYING OF CHEMICAL DETERGENT TANK (FSS VERSION)” on page 124.
	Clean the detergent tank on the automatic chemical detergent management system before extended periods of machine downtime, see “EMPTYING OF CHEMICAL DETERGENT TANK (FSS VERSION)” on page 124.
Battery-powered supply system	For the maintenance of the batteries utilised, follow the instructions contained in the document provided by the battery manufacturer.

ROUTINE MAINTENANCE

Before carrying out any routine maintenance operations, proceed as follows:

1. Take the machine to the maintenance area.

N.B.: the place designated for this operation must comply with current regulations concerning safety at work and current environmental protection regulations.

2. Sit on the driver's seat.
3. Insert the key (1) into the slot (2) on the right side of the column (**Fig.1**).
4. Turn on the machine and turn the key (1) a quarter turn clockwise (**Fig.2**).
5. Press the button (3) present on the control panel (**Fig.3**) to activate the maintenance function, see "[SERVICE FUNCTION](#)" on page 86.

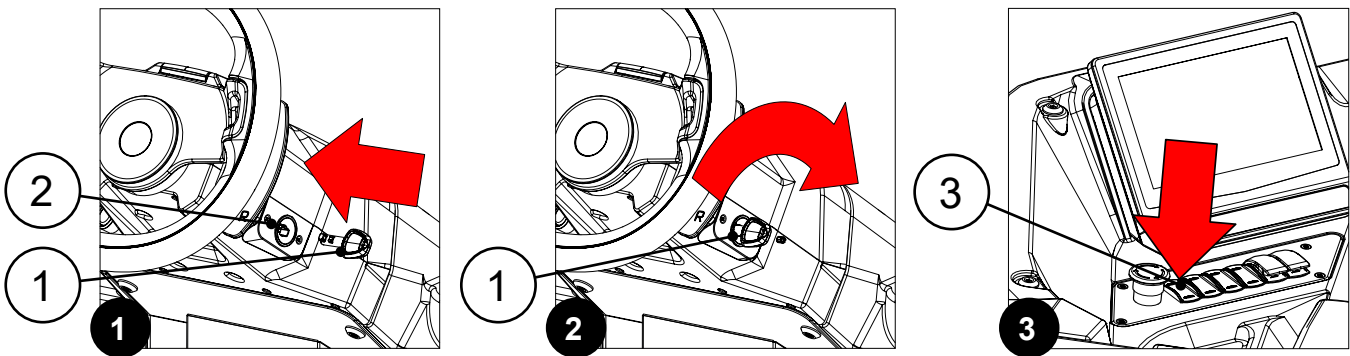

N.B.: once the maintenance sequence has been activated, it is not possible to activate other functions or move the machine.

CAUTION: make sure that no people or objects are in the machine's vicinity during this operation.

6. Bring the main switch to the "0" position by making a quarter turn anti-clockwise with the key (1) (**Fig.4**).
7. Remove the key from the instrument panel.
8. Get off the machine.
9. Remove the key from the instrument panel.
10. Get off the machine.

CAUTION: do not position your foot above the side brush head carter while the machine is descending.

11. Grasp the handle (4) and turn the battery compartment carter (5) to its maintenance position (**Fig.5**).

ATTENTION: to prevent the lid from turning, insert the retainer (6) into the slot (7) (**Fig.6**).

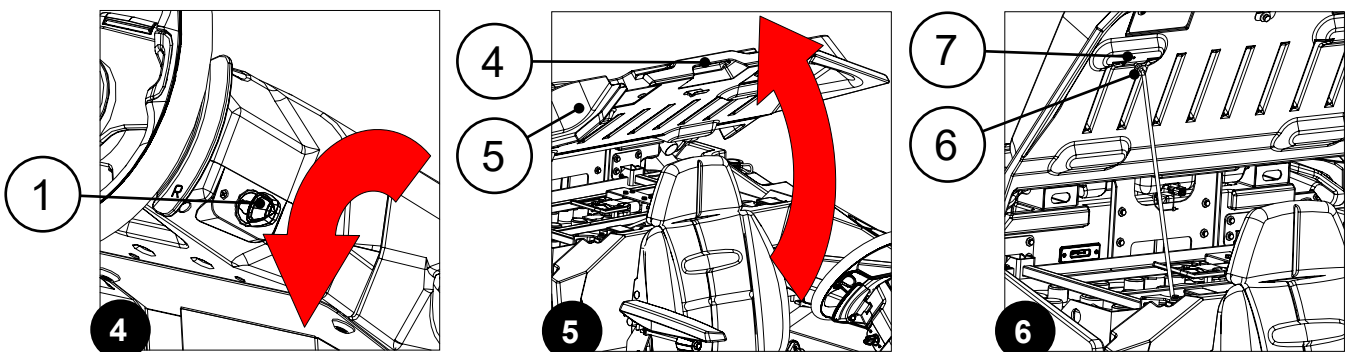

⚠ ATTENTION: the following operations must be carried out by qualified personnel. Incorrect operations could result in machine malfunctions.

12. Disconnect the machine's electrical system wiring connector (8) from the connector on the power cable coming from the battery box (**Fig. 7**).
13. Grasp the battery compartment lid and turn it to its working position.

i N.B.: release the retainer before turning the lid.

14. Set the detergent solution flow to its OFF position by turning the lever (9) under the operator's seat clockwise (**Fig. 8**).

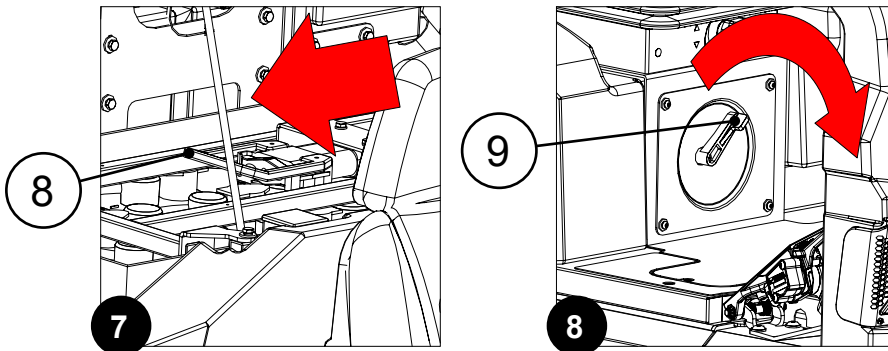

⚠ CAUTION: it is recommended to wear the appropriate PPE (Personal Protective Equipment), suitable for the work to be carried out.

CLEANING THE SQUEEGEE

The careful cleaning of the whole vacuum unit ensures better drying and cleaning of the floor as well as a longer vacuum motor life.

To clean the squeegee, proceed as follows:

1. Remove the squeegee vacuum hose (1) from the nozzle (2) in the squeegee (**Fig.1**).
2. Completely unscrew the knobs (3) in the squeegee pre-assembly (**Fig.2**).
3. Remove the squeegee from the slits in the squeegee connector (**Fig. 3**).

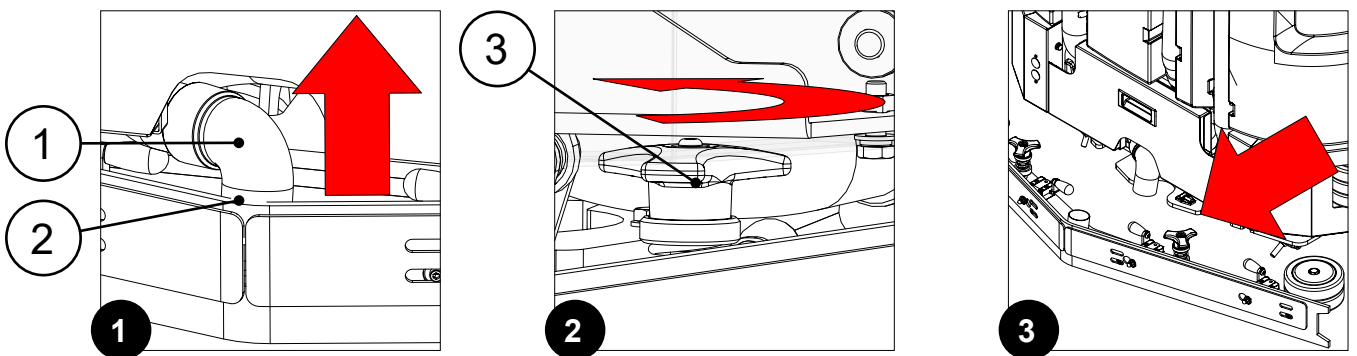

4. Use a jet of water and then a damp cloth to thoroughly clean the vacuum chamber (4) (**Fig.4**).

i N.B.: the vacuum chamber is to be understood as the portion of the squeegee unit located between the front squeegee rubber blade and the rear squeegee rubber blade.

i N.B.: if the dirt persists, use a brush with medium hardness bristles.

5. Use a jet of water and then a damp cloth to thoroughly clean the rear rubber blade (5) (**Fig.5**).
6. Use a jet of water and then a damp cloth to thoroughly clean the front rubber blade (6) (**Fig.5**).

i **N.B.:** Check the integrity of the two rubber blades, and replace the squeegee rubber blades if necessary, see [“REPLACING THE SQUEEGEE RUBBER BLADES” on page 146.](#)

7. Use a jet of water and then a damp cloth to thoroughly clean the suction nozzle (2) (**Fig.5**).

i **N.B.:** if the dirt persists, use a brush with medium hardness bristles.

8. Proceed in the opposite order to reassemble all the parts.

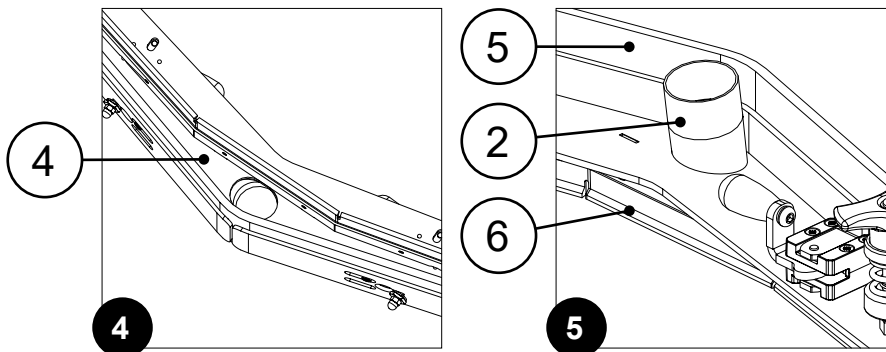

CLEANING THE SQUEEGEE VACUUM HOSE

The thorough cleaning of the squeegee vacuum hose guarantees better cleaning and drying of the floor, as well as a longer life for the suction motor.

To clean the squeegee vacuum hose, do the following:

1. Grasp the handle (1) and turn the battery compartment lid (2) to its maintenance position (**Fig.1**).

! **ATTENTION:** to prevent the lid from turning, insert the retainer (3) into the slot (4) (**Fig.2**).

! **ATTENTION:** the following operations must be carried out by qualified personnel. An incorrect connection of the connector may cause a malfunction of the device.

2. Connect the connector (5) in the battery box cable to the connector on the machine power cable (**Fig.3**).

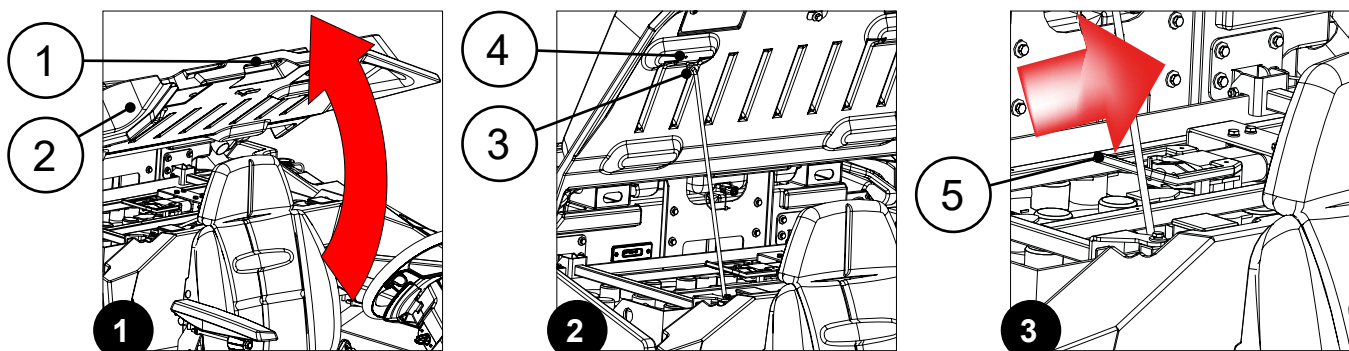

3. Grasp the battery compartment lid and turn it to its working position.

i **N.B.:** release the retainer before turning the lid.

4. Sit on the driver's seat.
5. Insert the key (6) into the slot (7) on the right side of the column (**Fig.4**).
6. Turn on the machine and turn the key (6) a quarter turn clockwise (**Fig.5**).
7. The machine is now operating with the ECO MODE working program, TRANSFER working mode.
8. Activate SCRUBBING-DRYING working mode, see "[DS SELECTOR \(DRIVE SELECT\)](#)" on page 70.
9. Activate the side brush, see "[SIDE BRUSH \(DISCOID SCRUBBING VERSIONS\)](#)" on page 104.
10. Press the drive pedal (8) (**Fig.6**) to begin moving the machine.

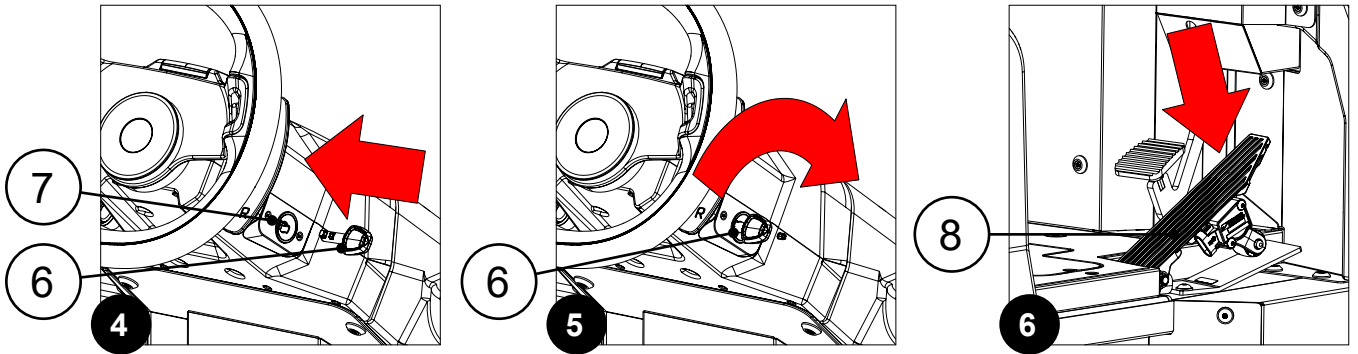

11. After about 30 seconds, turn off the machine and turn the key (6) a quarter turn anti-clockwise (**Fig.7**).
12. Remove the key from the slot on the right hand side of the steering column.
13. Position yourself to the side of the machine, grasp the handle (1) and turn the battery compartment lid (2) to its maintenance position (**Fig.1**).

⚠ ATTENTION: to prevent the lid from turning, insert the retainer (3) into the slot (4) (**Fig.2**).

⚠ ATTENTION: the following operations must be carried out by qualified personnel. An incorrect connection of the connector may cause a malfunction of the device.

14. Disconnect the connector (5) in the connector battery box cable on the machine power cable.
15. Grasp the battery compartment lid and turn it to its working position.

i N.B.: release the retainer before turning the lid.

16. Open the right inspection carter (9) (**Fig.8**).
17. Turn the squeegee support (10) anti-clockwise (**Fig.9**).

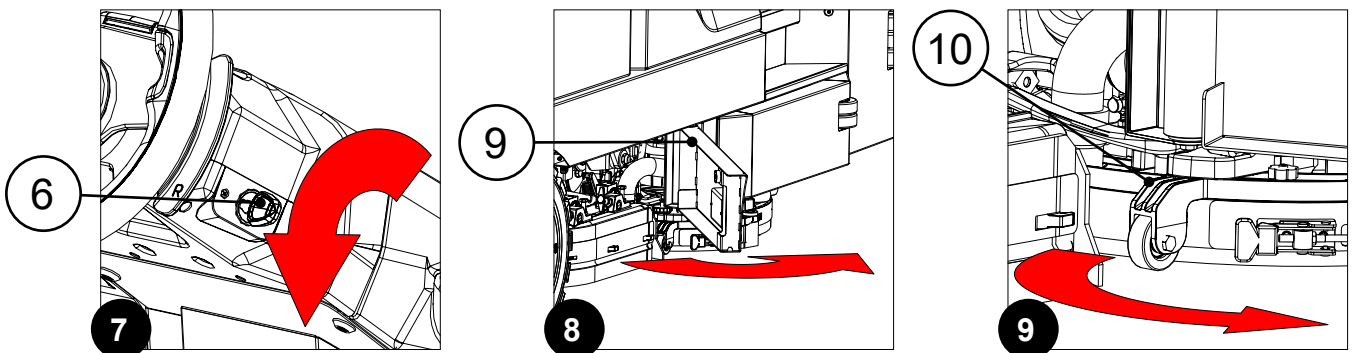

18. Remove the squeegee vacuum hose (11) from the nozzle (12) on the squeegee (**Fig.10**) and place it on the dirty water drain pan.
19. Stand at the back of the machine.
20. Remove the squeegee vacuum hose (13) from the nozzle (14) on the squeegee (**Fig.11**) and place it on the dirty water drain pan.
21. Position yourself at the rear of the machine, grasp the handle (15), and turn the recovery tank lid (16) to its maintenance position (**Fig.12**).

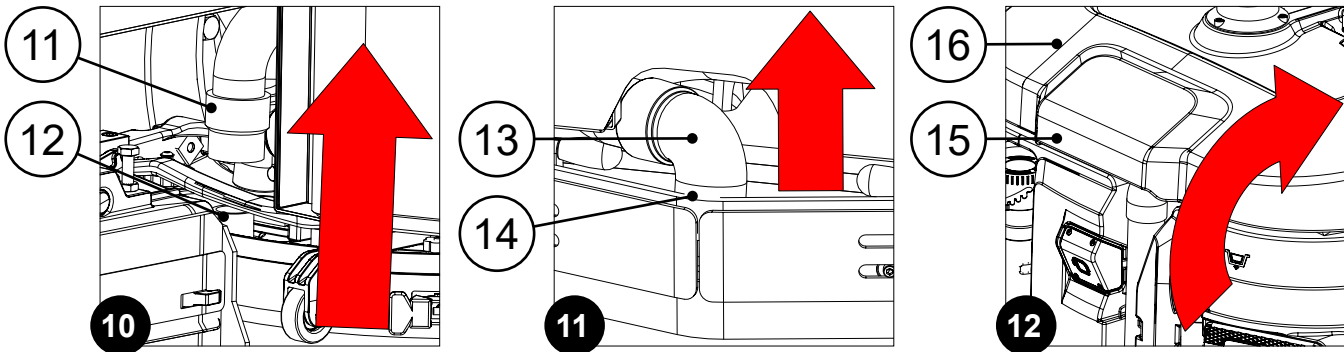

⚠ ATTENTION: to prevent the lid from turning, insert the retainer (17) into the slot (18) (Fig.13).

- 22. Remove the COLLECTION FILTER TRAY (19) (Fig.14).
- 23. Clean the inside of the vacuum hose (20) with a jet of running water (Fig.15).
- 24. Repeat the operations in reverse order to reassemble all the parts.

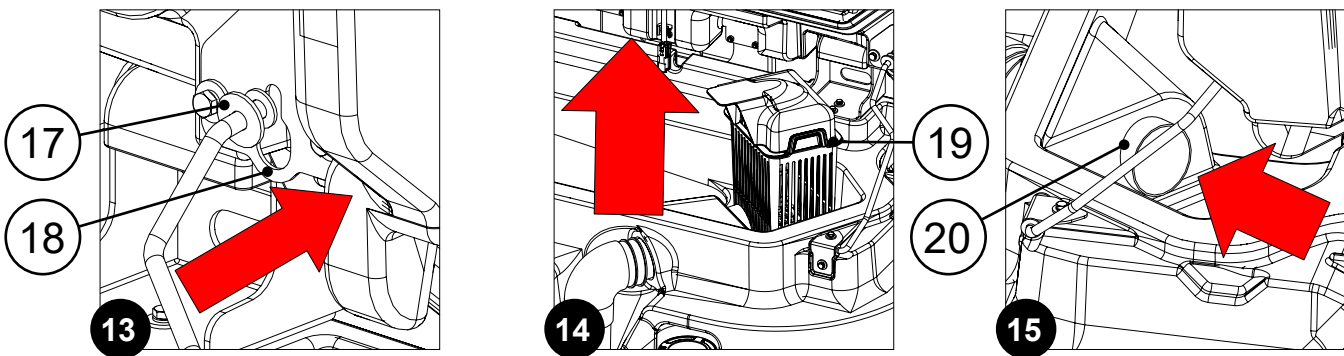

CLEANING THE COLLECTION FILTER TRAY

The thorough cleaning of the collection filter tray guarantees better drying and cleaning of the floor, as well as a longer life for the suction motor.

To clean the collection filter tray, do the following:

- 1. Grasp the handle (1) and turn the recovery tank's lid (2) to its maintenance position (Fig.1).

⚠ ATTENTION: to prevent the lid from turning, insert the retainer (3) into the slot (4) (Fig.2).

- 2. Remove the COLLECTION FILTER TRAY (5) (Fig.3).

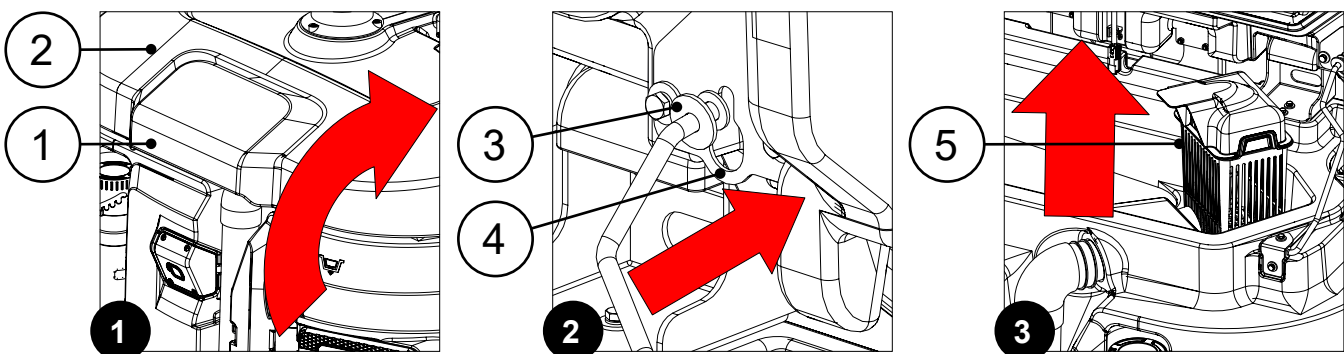

3. Remove the COLLECTION FILTER TRAY LID (6) (**Fig.4**).
4. Clean the collection filter tray and lid under a jet of running water.

i **N.B.:** Use a spatula or a brush with medium hardness bristles to eliminate any dirt that is particularly difficult to remove.

5. Use a cloth to dry the collection filter tray and lid, and place them back inside the recovery tank.
6. Repeat the operations in reverse order to reassemble all the parts.

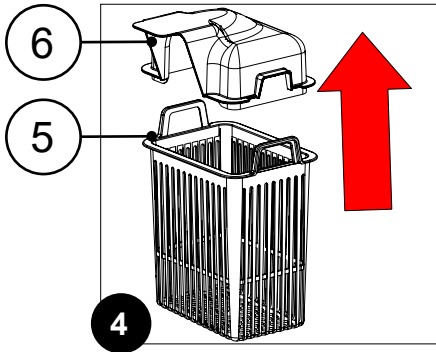

CLEANING THE WAVE PROTECTION TRAY

The thorough cleaning of the wave protection tray ensures better functionality and a longer working life for the suction motor.

To clean the wave protection tray, do the following:

1. Grasp the handle (1) and turn the recovery tank's lid (2) to its maintenance position (**Fig.1**).

! **ATTENTION:** to prevent the lid from turning, insert the retainer (3) into the slot (4) (**Fig.2**).

2. Remove the wave protection tray SUPPORT (5), remembering to unscrew the knobs (6) before removing the support (**Fig.3**).

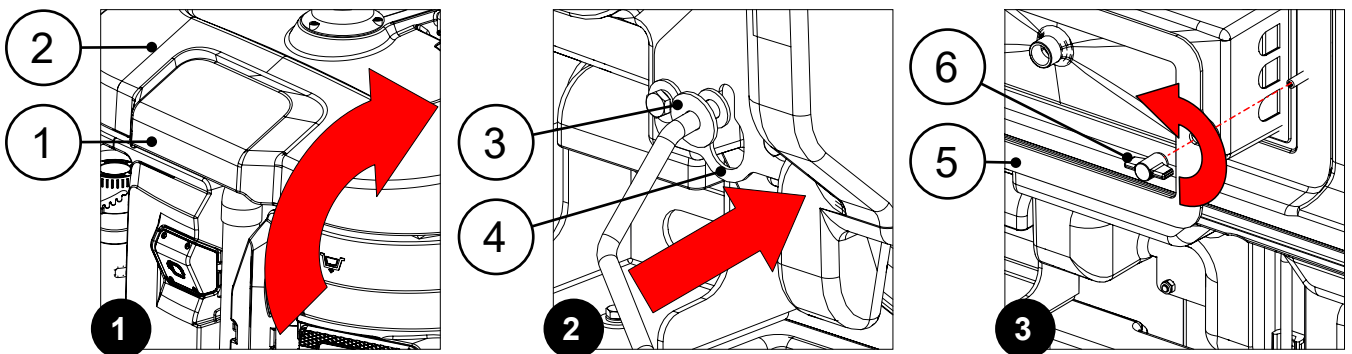

3. Remove the Wave protection tray (7) (**Fig.4**).
4. Clean the wave protection tray under a stream of running water.

i **N.B.:** Use a spatula or a brush with medium hardness bristles to eliminate any dirt that is particularly difficult to remove.

5. Use a cloth to dry the wave protection tray, and place it back inside the recovery tank.
6. Repeat the operations in reverse order to reassemble all the parts.

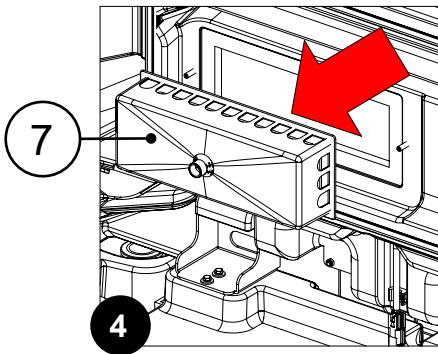

DRAINING THE RECOVERY TANK

Thoroughly cleaning the recovery tank will prevent unpleasant odours from forming inside. To clean the tank, do the following:

1. Remove the recovery tank drain hose (1) from the retainers (**Fig.1**).
2. Place the hose over the drain pan.

N.B.: discharges into the subsoil resulting from any work activities must only be carried out in designated areas; they must also be performed in compliance with the environmental regulations in force in the machine's country of use.

3. Gradually unscrew the cap (2) on the drainage hose (**Fig.2**).
4. Grasp the handle (3) and turn the recovery tank's lid (4) to its maintenance position (**Fig.3**).

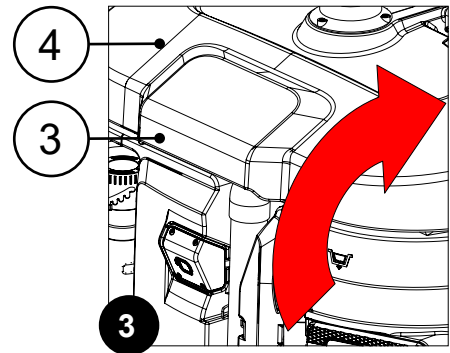
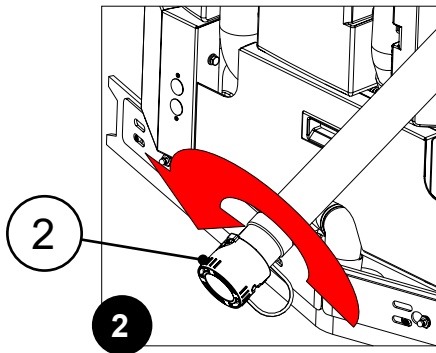
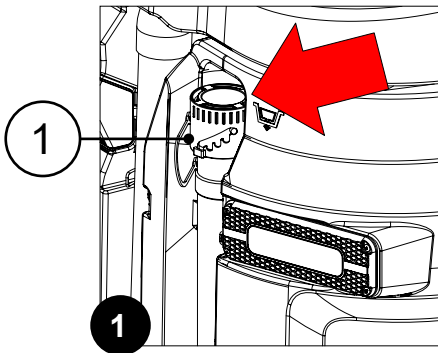

WARNING: to prevent the lid from turning, insert the retainer (5) into the slot (6) (**Fig.4**).

5. If necessary use the inspection footboard (7) at the back of the machine (**Fig.5**).

N.B.: to open the inspection footboard, grasp the handle (8), and rotate the footboard towards the outside of the machine (**Fig. 6**).

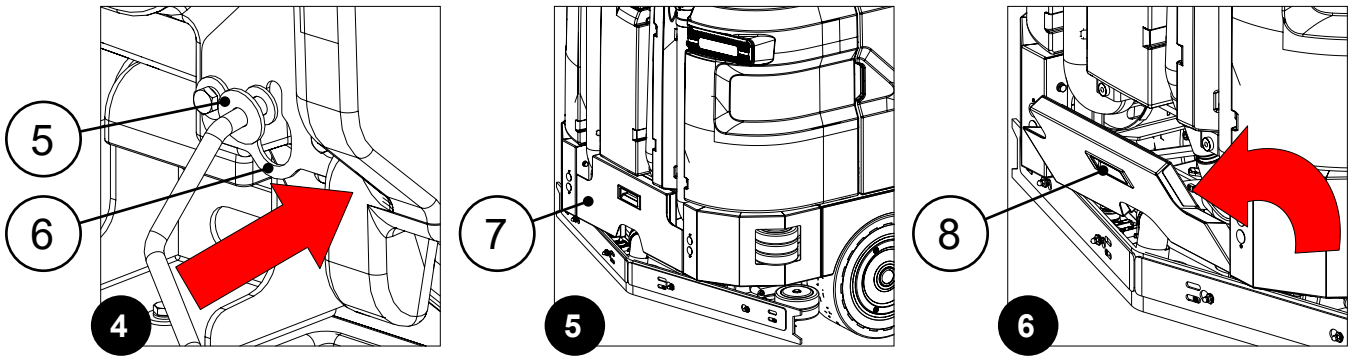

6. Rinse the inside of the recovery tank with a jet of running water.

i **N.B.:** If necessary, use a spatula to remove any sludge that may have accumulated at the bottom of the tank.

i **N.B.:** the inside of the tank can be cleaned with the optional recovery tank spray cleaning gun kit. If the machine is equipped with this kit, see [“RECOVERY TANK SPRAY CLEANING GUN” on page 100.](#)

7. Gently rinse the float switch (9) inside the recovery tank (**Fig.7**).

8. Clean the collection tray (10) (**Fig.8**), see [“CLEANING THE COLLECTION FILTER TRAY” on page 119.](#)

9. Clean the wave protection tray (11) (**Fig.9**), see [“CLEANING THE WAVE PROTECTION TRAY” on page 120.](#)

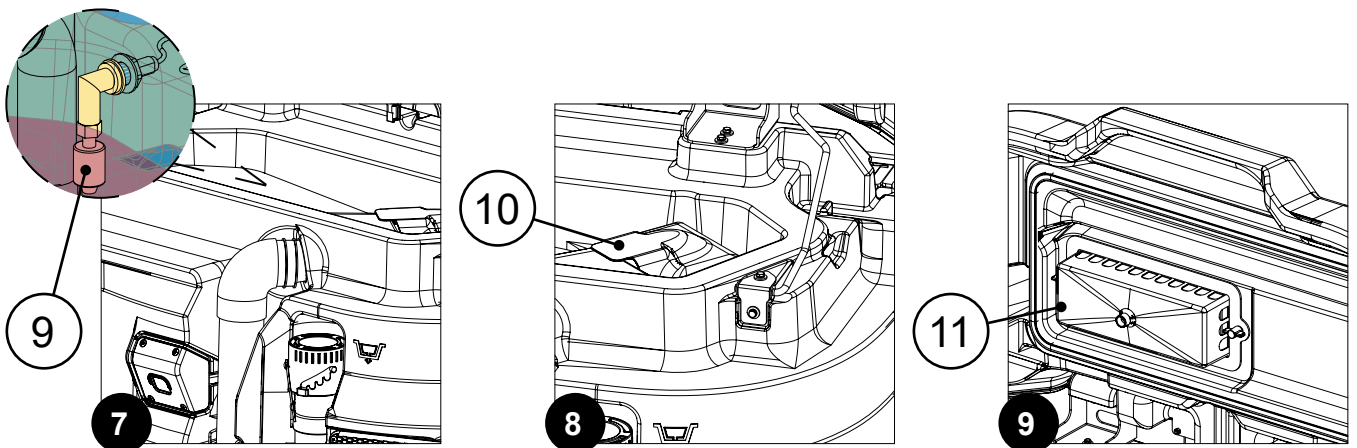

10. Repeat the operations in reverse order to reassemble all the parts.

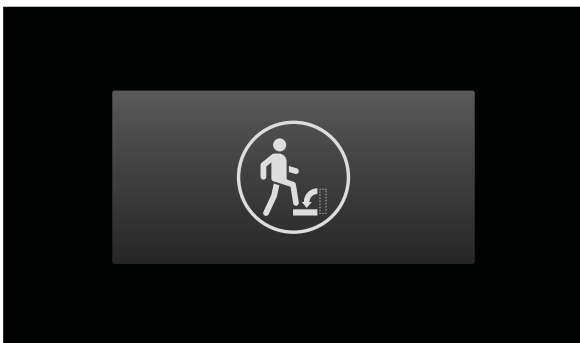

i **N.B.:** if the inspection footboard (7) is left open, the alarm message shown to the side will appear on the control display once the machine has been turned on.

i **N.B.:** with the inspection footboard open (7), the machine's functions will remain blocked until the footboard is closed.

CLEANING THE WATER SYSTEM FILTER

The thorough cleaning of the water system filter guarantees a more effective delivery to the brushes by the detergent solution delivery system, which in turn will ensure better floor cleaning, thus decreasing costs while at the same time improving environmental sustainability and performance. To clean the water system filter, do the following:

1. Open the inspection carter (1) (**Fig.1**).
2. Remove the cap from the filter body (2) (**Fig.2**).
3. Remove the filter cartridge from the filter body (3) (**Fig.3**).

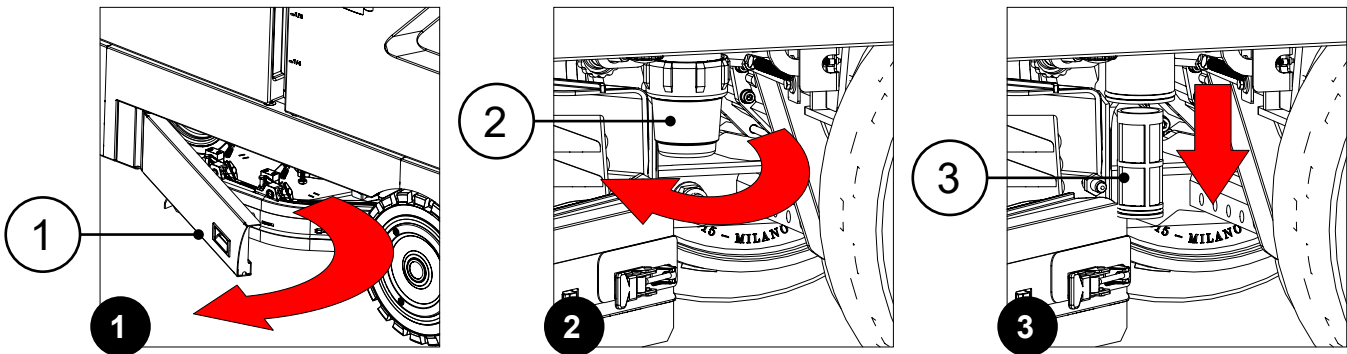

4. Rinse the filter cartridge under a jet of water, and use a brush to eliminate any impurities, if necessary.
5. Once the filter cartridge is clean, repeat the operations in the opposite order to reassemble all the parts.

EMPTYING THE SOLUTION TANK

Thoroughly cleaning the solution tank will prevent unpleasant odours from forming inside. To clean the tank, do the following:

1. Remove the solution tank drain hose (1) from the retainers (**Fig.1**).
2. Place the hose over the drain pan.

N.B.: discharges into the subsoil resulting from any work activities must only be carried out in designated areas; they must also be performed in compliance with the environmental regulations in force in the machine's country of use.

3. Gradually unscrew the cap (2) on the drainage hose (**Fig.2**).
4. Remove the filler cap (3) (**Fig.3**).

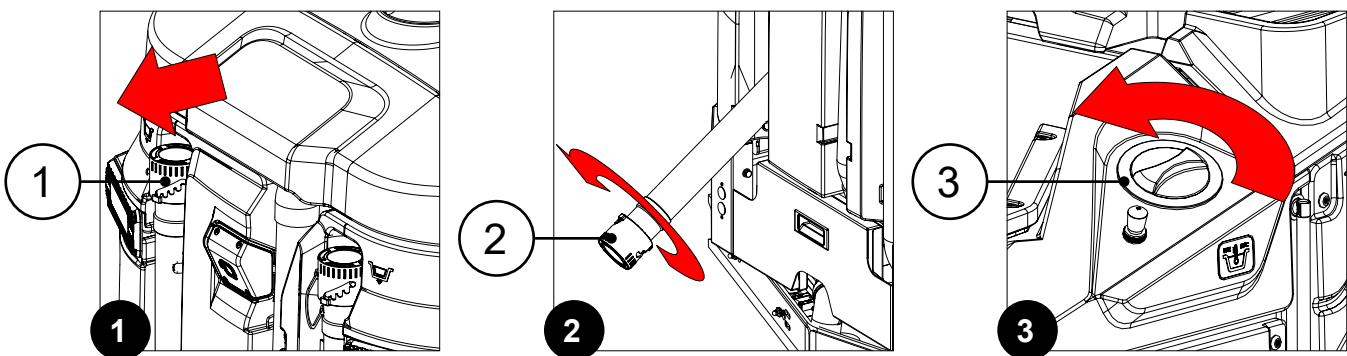

5. Clean the inside of the tank with a jet of running water.
6. Once the work has been completed, repeat the operations in reverse order to reassemble all the parts.

CLEANING THE FILTER ON THE AUTOMATIC CHEMICAL DETERGENT MANAGEMENT SYSTEM (FSS VERSION)

The thorough cleaning of the automatic chemical detergent management system filter guarantees a more effective delivery to the brushes by the detergent solution delivery system, which in turn will ensure better floor cleaning, thus decreasing costs while at the same time improving environmental sustainability and performance.

To clean the automatic chemical detergent management system filter, do the following:

1. Open the left inspection door (1) (**Fig.1**).
2. Close the automatic detergent management system's outlet flow tap by turning the lever (2) on the tap's body clockwise (**Fig.2**).
3. Remove the cap from the filter body (3) (**Fig.3**).

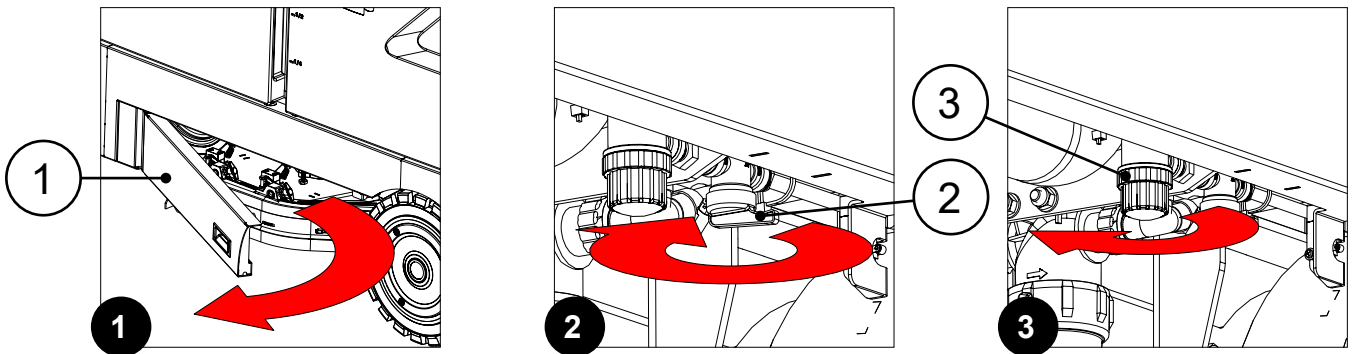

4. Remove the filter cartridge from the filter body.
5. Rinse the filter cartridge under a jet of water, and use a brush to eliminate any impurities, if necessary.
6. Once the filter cartridge is clean, repeat the operations in the opposite order to reassemble all the parts.

EMPTYING OF CHEMICAL DETERGENT TANK (FSS VERSION)

Thoroughly cleaning the chemical detergent tank will prevent unpleasant odours from forming inside. To clean the tank, do the following:

1. Open the left inspection door (1) (**Fig.1**).
2. Close the automatic detergent management system's outlet flow tap by turning the lever (2) on the tap's body clockwise (**Fig.2**).
3. Remove the cap from the filter body (3) (**Fig.3**).

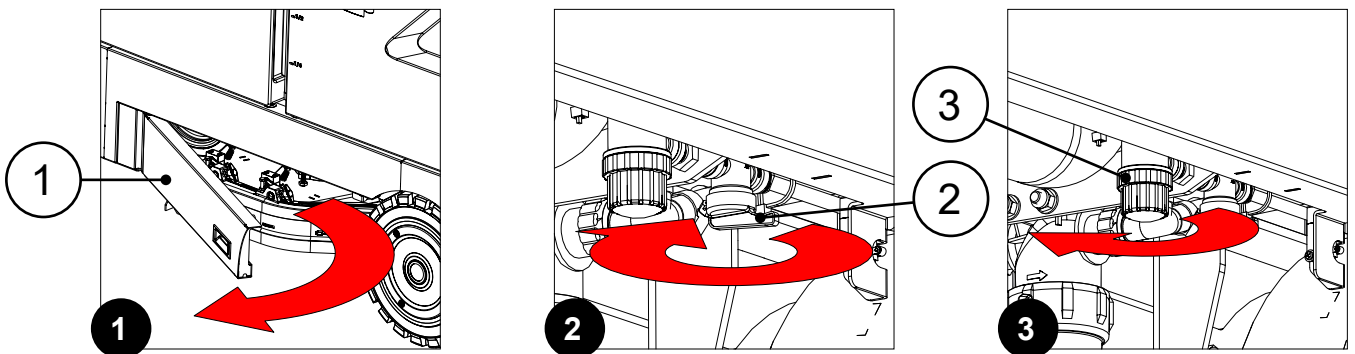

4. Remove the filter cartridge from the filter body.
5. Grasp the handle (4) and turn the battery compartment lid (5) to its maintenance position (**Fig.4**).

⚠ ATTENTION: to prevent the lid from turning, insert the retainer (6) into the slot (7) (**Fig.5**).

6. Remove the cap (8) on the top of the chemical detergent tank (Fig. 6).

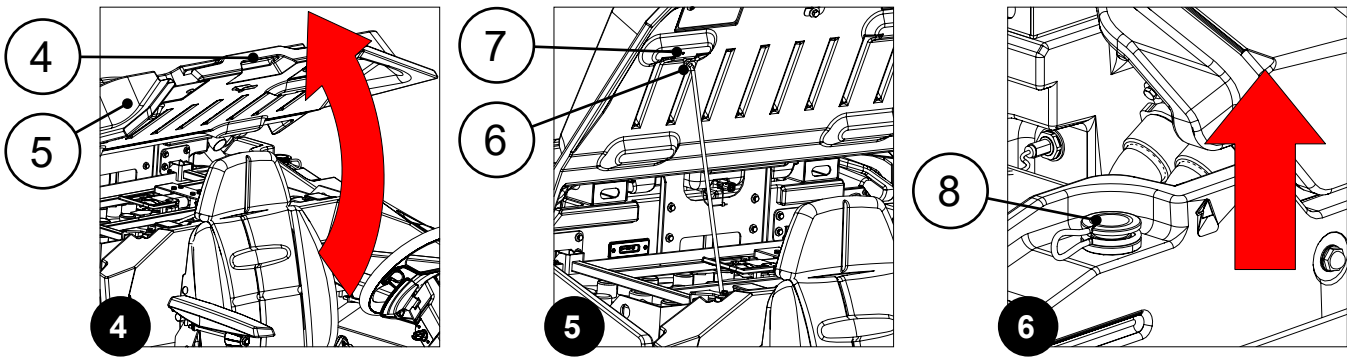

7. Open the automatic detergent management system's outlet flow tap by turning the lever (2) on the tap's body anti-clockwise.

8. Clean the inside of the chemical detergent tank with a jet of running water.

9. Once the work has been completed, repeat the operations in reverse order to reassemble all the parts.

CLEANING THE FILTER ON THE DETERGENT SOLUTION RECYCLING SYSTEM (FLR VERSION)

The thorough cleaning of the detergent solution recycling system filter guarantees a more effective delivery to the brushes by the detergent solution delivery system, which in turn will ensure better floor cleaning, thus decreasing costs while at the same time improving environmental sustainability and performance.

To clean the detergent solution recycling system filter, do the following:

1. Grasp the handle (1) and turn the recovery tank's lid (2) to its maintenance position (Fig.1).

⚠ ATTENTION: to prevent the lid from turning, insert the retainer (3) into the slot (4) (Fig.2).

2. Remove the DETERGENT SOLUTION RECYCLING SYSTEM FILTER SUPPORT (5) (Fig.3).

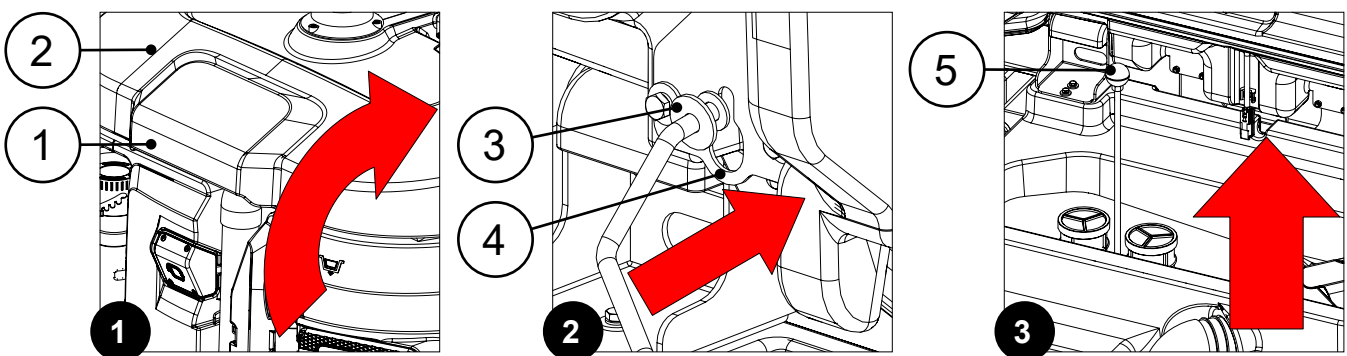

3. Clean the two filters under a stream of running water.

i N.B.: Use a spatula or a brush with medium hardness bristles to eliminate any dirt that is particularly difficult to remove.

4. Repeat the operations in reverse order to reassemble all the parts.

CLEANING OF BRUSH HEAD DRIVE BRUSH - DISC (DISCOID SCRUBBING VERSIONS)

The thorough cleaning of the brush or the drive disc on the brush head will ensure better floor cleaning, thus decreasing costs while at the same time improving environmental sustainability and performance.

To clean the brush or the drive disc on the brush head, using the brush uncoupling function, do the following:

1. Grasp the handle (1) and turn the battery compartment lid (2) to its maintenance position (**Fig.1**).

⚠ ATTENTION: to prevent the lid from turning, insert the retainer (3) into the slot (4) (**Fig.2**).

⚠ ATTENTION: the following operations must be carried out by qualified personnel. An incorrect connection of the connector may cause a malfunction of the device.

2. Connect the battery charger cable connector (5) to the connector on the power cable coming from the battery box (**Fig.3**).

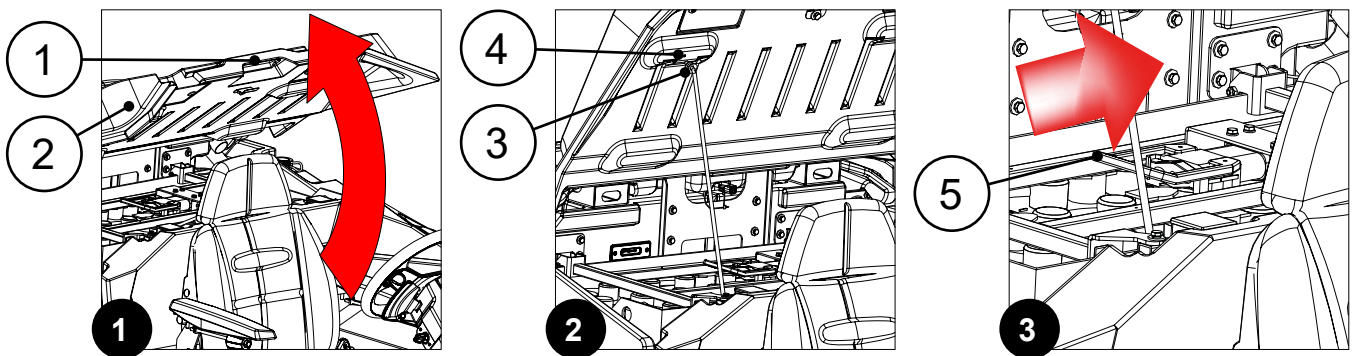

3. Grasp the battery compartment lid and turn it to its working position.

i N.B.: release the retainer before turning the lid.

4. Sit on the driver's seat.
5. Insert the key (6) into the slot (7) on the right side of the column (**Fig.4**).
6. Turn on the machine and turn the key (6) a quarter turn clockwise (**Fig.5**).

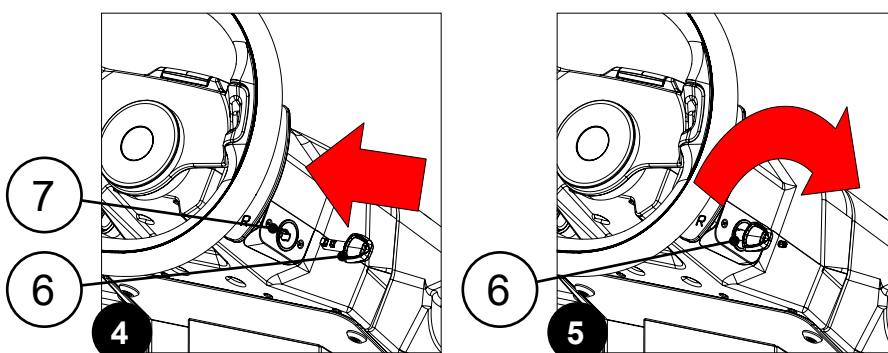

7. Activate the brush uncoupling function, see .
8. After removing the brushes or drive discs, clean them under a stream of running water to eliminate any impurities from the bristles.

i **N.B.:** check the wear of the bristles and replace the brushes if they are excessively worn (the bristle length must not be less than 10 mm; this measurement is indicated on the brush by the yellow band), see [“REPLACEMENT OF BRUSH HEAD DRIVE BRUSHES OR DISCS \(DISCOID SCRUBBING VERSION\)”](#) on page 141.

9. When cleaning is complete, refit the brushes, see.

i **N.B.:** You are advised to invert the right and left-hand brushes every day.

! **ATTENTION:** If the brushes are not new and have deformed bristles, it is better to reassemble them in the same position (the right-hand one on the right, and the left-hand one on the left), to prevent the different inclination of the bristles from producing an overload on the brush motor as well as excessive vibrations.

To clean the brush or the drive disc on the brush head, not using the brush uncoupling function, do the following:

1. Open the left inspection door (1) (Fig.1).
2. Set the fastening anchors (2) on the lateral splash guard support to their maintenance position, move them upwards, and turn them a quarter turn clockwise (Fig.2).
3. Remove the left side splash guard support (3) located in the brush head (Fig.3).

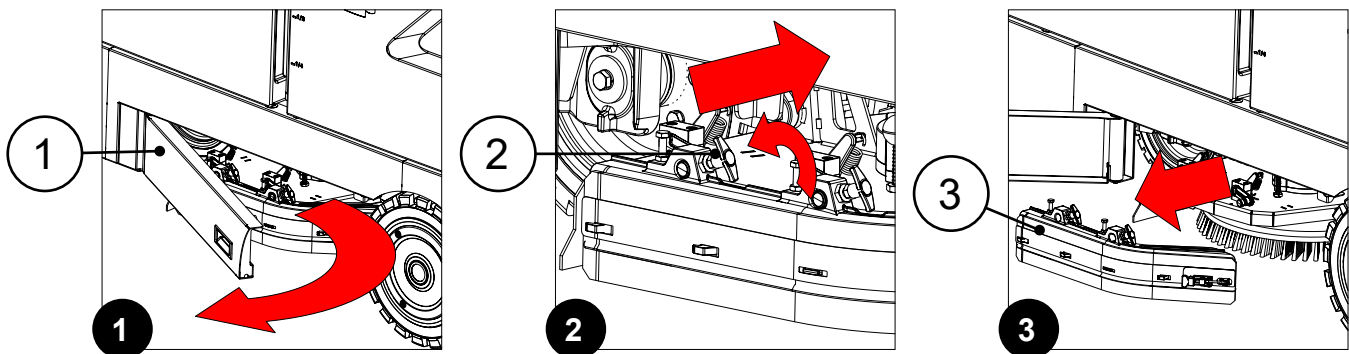

4. Keeping the pin (4) pressed, turn the brush (5) clockwise until it is locked in place (Fig.4).

i **N.B.:** turn the brush quickly and firmly so as to push the button on the coupling spring outward until it releases (Fig.4).

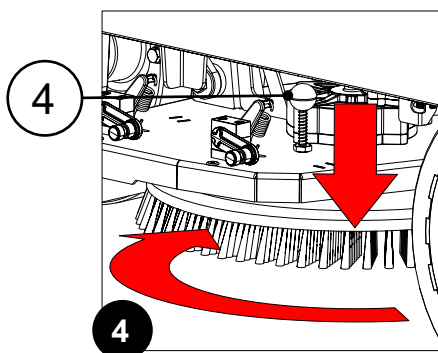

5. With the brush or drive disc removed, clean it under a stream of running water to eliminate any impurities from its bristles.

i **N.B.:** check the wear of the bristles and replace the brushes if they are excessively worn (the bristle length must not be less than 10 mm; this measurement is indicated on the brush by the yellow band), see [“REPLACEMENT OF BRUSH HEAD DRIVE BRUSHES OR DISCS \(DISCOID SCRUBBING VERSION\)”](#) on page 141.

- After cleaning, refit the brush, see [“ASSEMBLY OF BRUSHES OR DRIVE DISCS \(DISCOID SCRUBBING VERSION\)”](#) on page 49.

i **N.B.:** You are advised to invert the right and left-hand brushes every day.

⚠ **ATTENTION:** If the brushes are not new and have deformed bristles, it is better to reassemble them in the same position (the right-hand one on the right, and the left-hand one on the left), to prevent the different inclination of the bristles from producing an overload on the brush motor as well as excessive vibrations.

- Close the left inspection door.
- Repeat the operation just performed on the right side as well.

CLEANING OF BRUSH HEAD SIDE SPLASH GUARD (DISCOID SCRUBBING VERSION)

The careful cleaning of the splash guards in the brush head will ensure better floor cleaning, thus decreasing costs while at the same time improving environmental sustainability and performance.

To clean the brush head splash guards, proceed as follows:

- Open the left inspection door (1) (**Fig.1**).
- Set the fastening anchors (2) on the lateral splash guard support to their maintenance position, move them upwards, and turn them a quarter turn clockwise (**Fig.2**).
- Remove the left side splash guard support (3) located in the brush head (**Fig.3**).

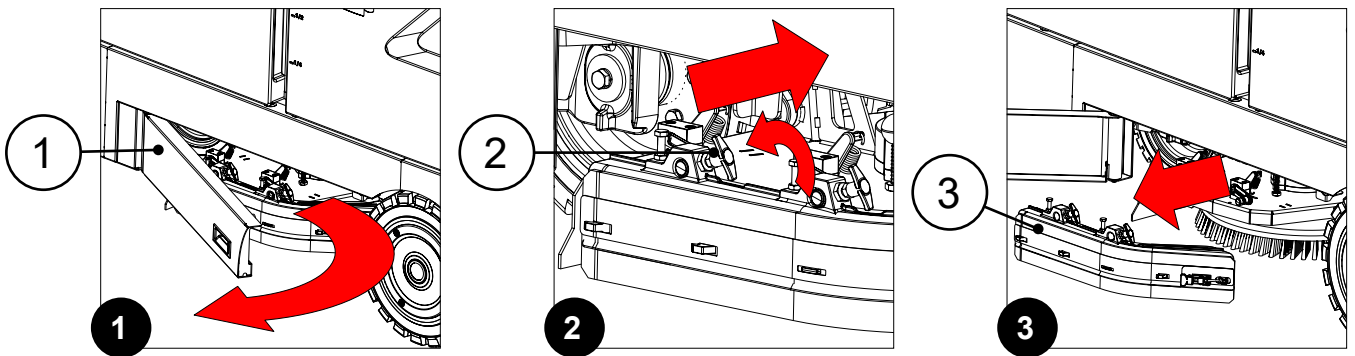

- With the lateral splash guard support removed from the machine, clean the rubber splash guard blade with a damp cloth to eliminate any impurities present.

i **N.B.:** check the wear of the splash guard rubber blade, if there is excessive wear replace it with a new one, see [“REPLACEMENT OF BRUSH HEAD SIDE SPLASH GUARD \(DISCOID SCRUBBING VERSION\)”](#) on page 143.

- Repeat the operation just performed on the right side as well.

CLEANING OF SIDE BRUSH HEAD DRIVE BRUSH - DISC (DISCOID SCRUBBING VERSION)

The thorough cleaning of the brush or the drive disc on the side brush head will ensure better floor cleaning, thus decreasing costs while at the same time improving environmental sustainability and performance.

To replace the brush or drive disc on the side brush head, do the following:

- Stand on the right side of the machine.
- Moving the brush uncoupling lever (1), rotate the brush anti-clockwise until it stops (**Fig.1**).

i **N.B.:** turn the brush quickly and firmly so as to push the button on the coupling spring outward until it releases (**Fig.2**).

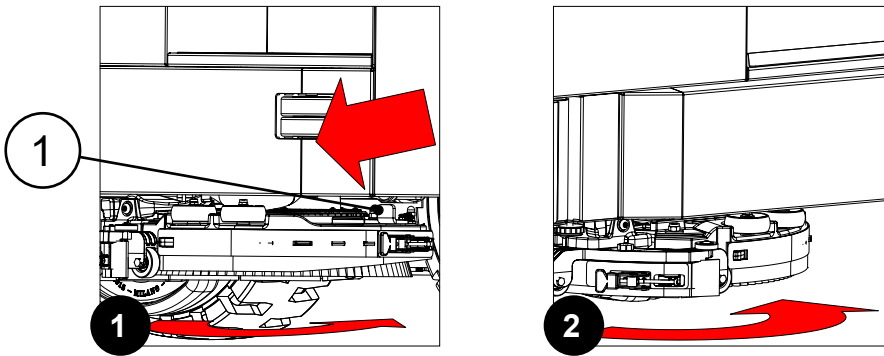

3. Clean it under a stream of running water to eliminate any impurities.

i **N.B.:** check the wear of the bristles and replace the brush if excessively worn (the bristle length must not be less than 10 mm; this measurement is indicated on the brush by the yellow band), see [“REPLACEMENT OF SIDE BRUSH HEAD DRIVE BRUSH OR DISCS \(DISCOID SCRUBBING VERSION\)”](#) on page 144.

4. After cleaning, refit the brush, see [“ASSEMBLY OF THE SIDE BRUSH HEAD BRUSH OR DRIVE DISCS \(DISCOID SCRUBBING VERSION\)”](#) on page 53.

CLEANING OF SIDE BRUSH HEAD SPLASH GUARD (DISCOID SCRUBBING VERSION)

The careful cleaning of the splash guards in the side brush head will ensure better floor cleaning, thus decreasing costs while at the same time improving environmental sustainability and performance.

To clean the side brush head splash guards, do the following:

1. Stand on the right side of the machine.
2. Remove the rubber blade compression plate on the side brush head, and release the retainer (1) at the front of the brush head (**Fig.1**).
3. Remove the side brush head splash guard rubber blade (2) from the side brush head (**Fig.2**).

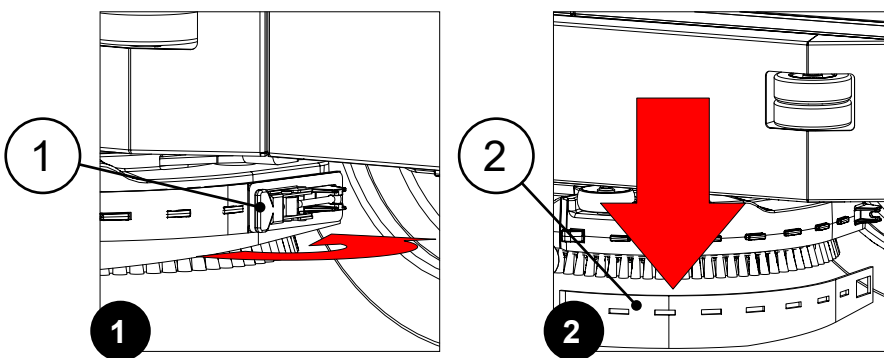

4. Clean the rubber splash guard blade with a damp cloth to eliminate any impurities present.

i **N.B.:** check the wear of the splash guard rubber blade, if there is excessive wear replace it with a new one, see [“REPLACEMENT OF SIDE BRUSH HEAD SPLASH-GUARD RUBBER BLADE \(DISCOID SCRUBBING VERSION\)”](#) on page 144.

5. Repeat the operations described above in reverse order to reassemble all the parts.

CLEANING OF SIDE BRUSH HEAD SQUEEGEE (DISCOID SCRUBBING VERSION)

The careful cleaning of the whole vacuum unit ensures better drying and cleaning of the floor as well as a longer vacuum motor life.

To clean the squeegee in the side brush head, proceed as follows:

1. Open the right inspection carter (1) (**Fig.1**).
2. Turn the squeegee support (2) anti-clockwise (**Fig.2**).
3. Remove the squeegee vacuum hose (3) from the nozzle (4) in the squeegee (**Fig.3**).

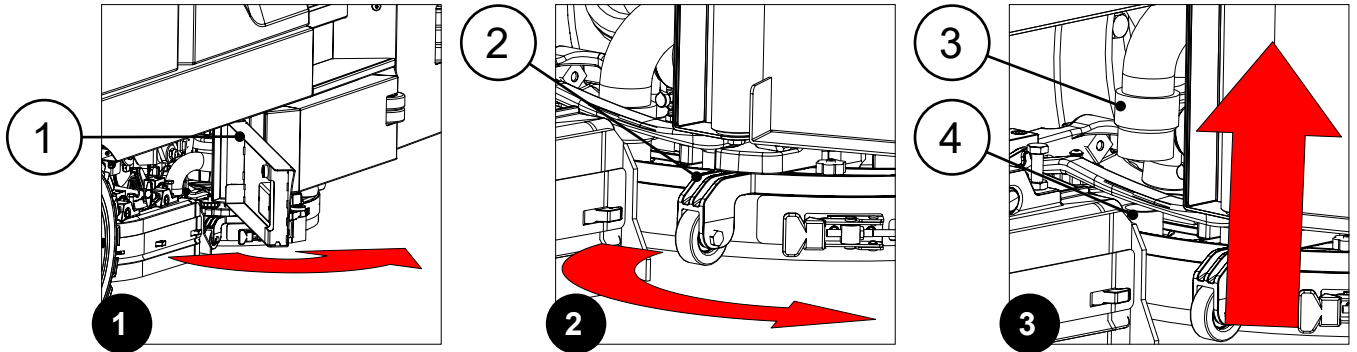

4. Completely unscrew the knobs (5) in the squeegee pre-assembly (**Fig.4**).
5. Remove the squeegee from the slits in the squeegee connector (**Fig. 5**).
6. Use a jet of water and then a damp cloth to thoroughly clean the vacuum chamber (6) (**Fig.6**).

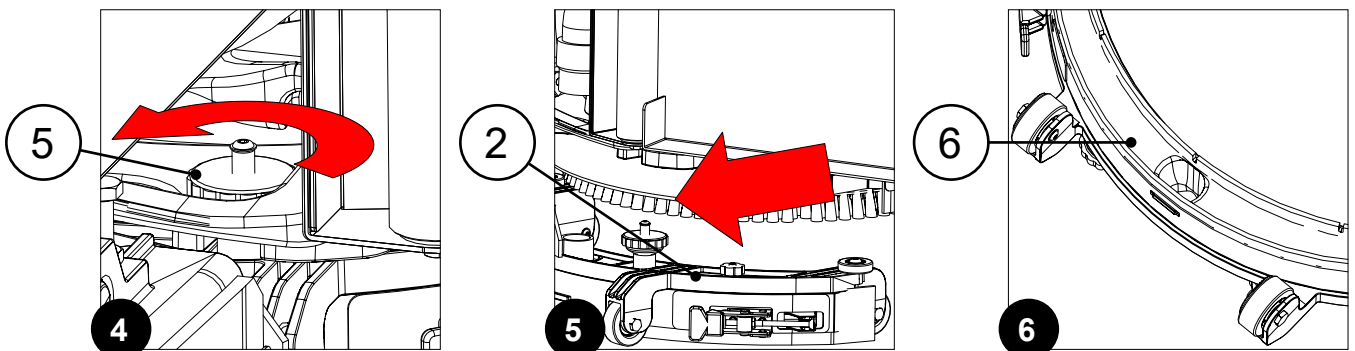

i **N.B.:** the vacuum chamber is to be understood as the portion of the squeegee unit enclosed between the front squeegee rubber blade and the squeegee rubber blade.

i **N.B.:** if the dirt persists, use a brush with medium hardness bristles.

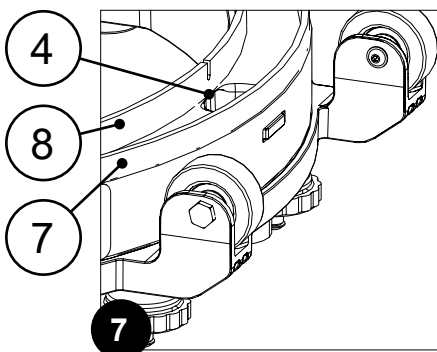

7. Use a jet of water and then a damp cloth to thoroughly clean the rear rubber blade (7) (**Fig.7**).
8. Use a jet of water and then a damp cloth to thoroughly clean the front rubber blade (8) (**Fig.7**).

i **N.B.:** Check the integrity of the two rubber blades, and replace the squeegee rubber blades if necessary, see [“REPLACEMENT OF SIDE BRUSH HEAD SQUEEGEE RUBBER BLADES \(DISCOID SCRUBBING VERSION\)”](#) on page 145.

9. Use a jet of water and then a damp cloth to thoroughly clean the suction nozzle (4) (**Fig.7**).

10. Proceed in the opposite order to reassemble all the parts.

CLEANING OF BRUSH HEAD BRUSH (CYLINDRICAL SCRUBBING VERSIONS)

Careful cleaning of the brushes in the brush head will ensure better floor cleaning, thus decreasing costs while at the same time improving environmental sustainability and performance. To clean the brushes in the brush head, proceed as follows:

CAUTION: it is recommended to wear the appropriate PPE (Personal Protective Equipment), suitable for the work to be carried out.

1. Open the left inspection door (1) (**Fig.1**).
2. Set the fastening anchors (2) on the side splash guard support to their maintenance position, move them upwards, and turn them a quarter turn clockwise (**Fig.2**).
3. Remove the left side splash guard (3) from the brush head (**Fig.3**).

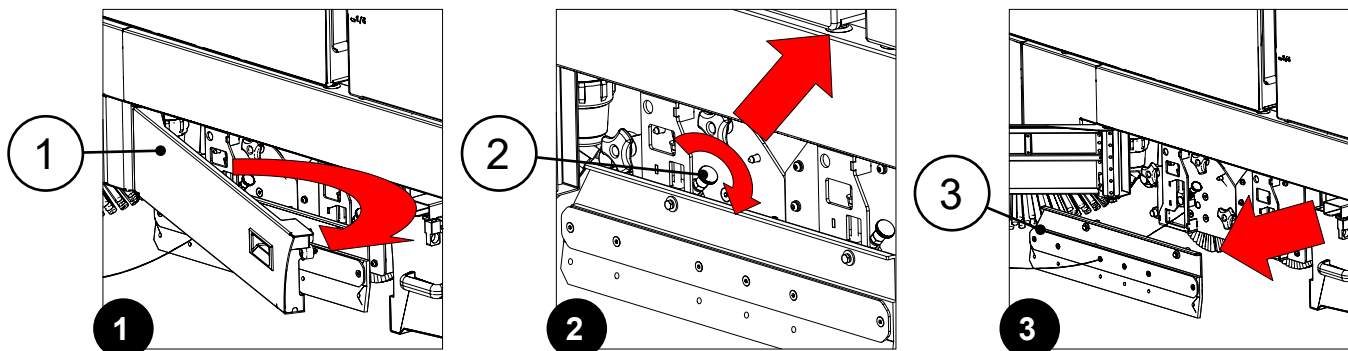

4. Remove the knobs (4) that secure the front brush support (5) (**Fig.4**).
5. Extract the front brush support (5) from the brush head (**Fig.5**).
6. Extract the brush (6) from the brush head body (**Fig.6**).

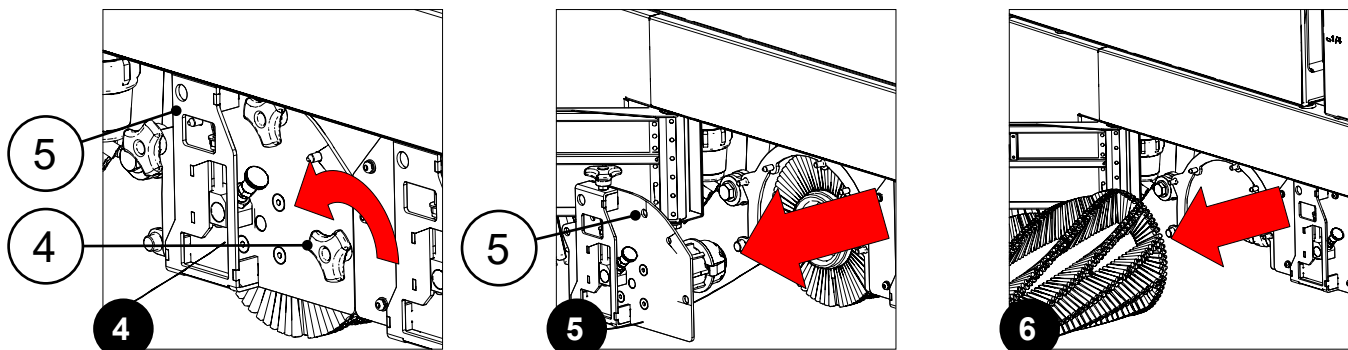

7. Clean the brush under a stream of running water to remove any impurities from its bristles.

N.B.: check the wear of the bristles and replace the brushes if they are excessively worn (the bristle length must not be less than 15 mm; this measurement is indicated on the brush by the yellow band), see [“REPLACING THE BRUSH HEAD BRUSHES \(CYLINDRICAL SCRUBBING VERSION\)”](#) on page 148.

8. After cleaning, refit the brush, see [“FITTING OF BRUSHES \(CYLINDRICAL SCRUBBING VERSION\)”](#) on page 54.

N.B.: you are advised to invert the front and rear brushes every day.

ATTENTION: If the brushes are not new, and have deformed bristles, it is better to reassemble them in the same position in order to prevent the different inclination of the bristles from overloading the brush motor, as well as to prevent excessive vibrations.

9. Close the left inspection door.
10. Repeat the operation just performed on the right side as well.

CLEANING OF BRUSH HEAD SIDE SPLASH GUARD (CYLINDRICAL SCRUBBING VERSION)

The careful cleaning of the splash guards in the brush head will ensure better floor cleaning, thus decreasing costs while at the same time improving environmental sustainability and performance.

To clean the brush head splash guards, proceed as follows:

1. Activate the maintenance position function, see [“SERVICE FUNCTION” on page 86](#).
2. Perform all the operations required to secure the machine. See [“MACHINE SAFETY” on page 35](#).



CAUTION: it is recommended to wear the appropriate PPE (Personal Protective Equipment), suitable for the work to be carried out.

3. Open the left inspection door (1) (**Fig.1**).
4. Set the fastening anchors (2) on the side splash guard support to their maintenance position, move them upwards, and turn them a quarter turn clockwise (**Fig.2**).
5. Remove the left side splash guard (3) from the brush head (**Fig.3**).

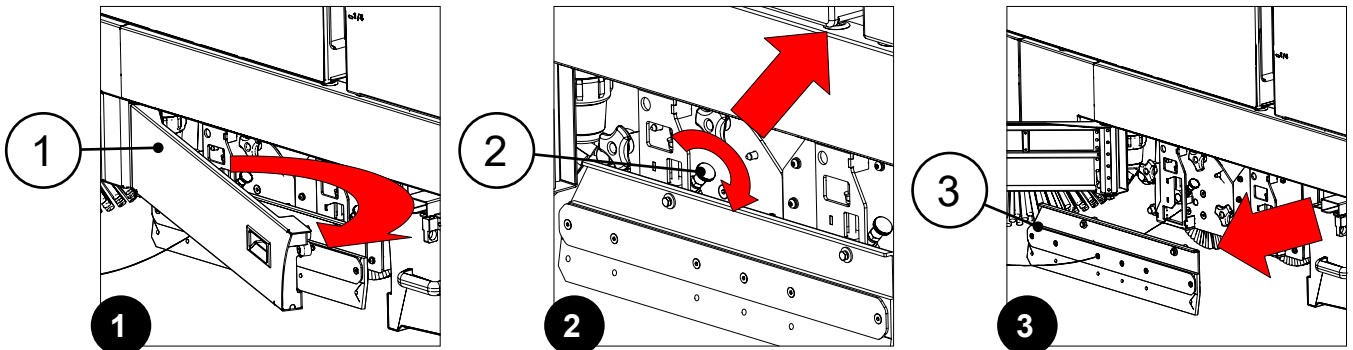

6. With the lateral splash guard support removed from the machine, clean the rubber splash guard blade with a damp cloth to eliminate any impurities present.



N.B.: check the wear of the splash guard rubber blade, if there is excessive wear replace it with a new one, see [“REPLACEMENT OF BRUSH HEAD SIDE SPLASH GUARD \(CYLINDRICAL SCRUBBING VERSION\)” on page 148](#).

7. Repeat the operation just performed on the right side as well.

CLEANING THE DEBRIS HOPPER (CYLINDRICAL SCRUBBING VERSION)

The careful cleaning of the debris hopper in the brush head will ensure better floor cleaning, thus decreasing costs while at the same time improving environmental sustainability and performance.

To empty the debris hopper, proceed as follows:

1. Activate the maintenance position function, see [“SERVICE FUNCTION” on page 86](#).
2. Perform all the operations required to secure the machine. See [“MACHINE SAFETY” on page 35](#).



CAUTION: it is recommended to wear the appropriate PPE (Personal Protective Equipment), suitable for the work to be carried out.

3. Open the left inspection door (1) (**Fig.1**).
4. Remove the debris hopper from the machine using the handle (2), before moving the hopper remember to release the debris hopper latch (3) (**Fig.2**).

5. Move the debris hopper in the place used for waste disposal using the handle (2).

N.B.: the place designated for this operation must comply with current regulations concerning safety at work and current environmental protection regulations.

6. Clean the inside of the debris hopper with a stream of running water, using a brush to remove any dirt residues if necessary.
7. Take out the debris hopper vacuum filter (4) (**Fig.3**), clean it with a jet of water, if necessary use a scraper to remove any residues of dirt.
8. Proceed in the opposite order to reassemble all the parts.

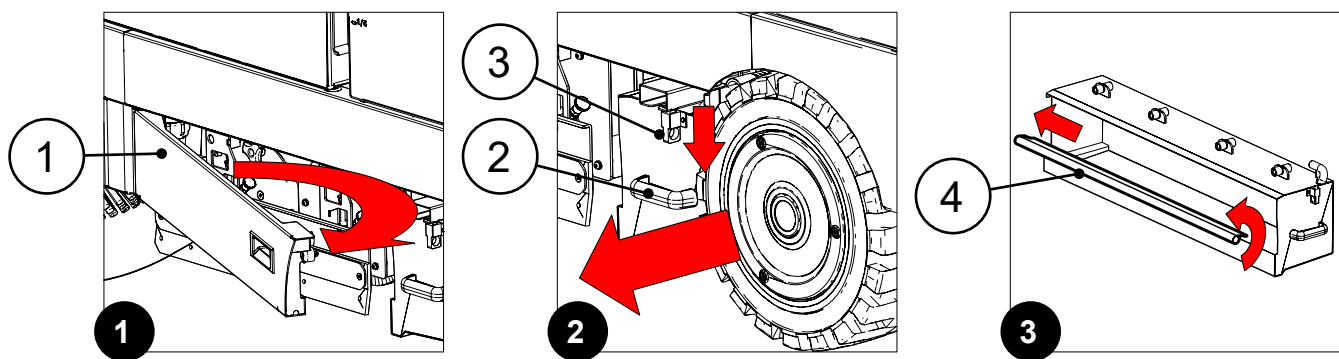

CLEANING THE SIDE BRUSH (CYLINDRICAL - COMBINED SCRUBBING VERSION)

The thorough cleaning of the brush or the drive disc on the side brush head will ensure better floor cleaning, thus decreasing costs while at the same time improving environmental sustainability and performance.

To replace the side brush, do the following:

1. Perform all the operations required to secure the machine. See [“MACHINE SAFETY” on page 35](#).

CAUTION: it is recommended to wear the appropriate PPE (Personal Protective Equipment), suitable for the work to be carried out.

2. Stand on the left front side of the machine.
3. Remove the knob (1) fixing the side brush to the gear motor by rotating the right brush clockwise and the left brush anti-clockwise (**Fig.1**).
4. Remove the washer (2) holding the side brush in place (**Fig.2**).
5. Extract the brush from the flange and clean it under a stream of running water to remove any impurities from its bristles.

N.B.: check the bristles are not excessively worn. If necessary, replace the brush - see [“REPLACEMENT OF THE SIDE BRUSH \(CYLINDRICAL-COMBINED SCRUBBING VERSION\)” on page 150](#).

6. After cleaning, reassemble the brush, making sure to correctly position the pins (3), present in the brush support, in the holes (4), present in the brush (**Fig.3**).

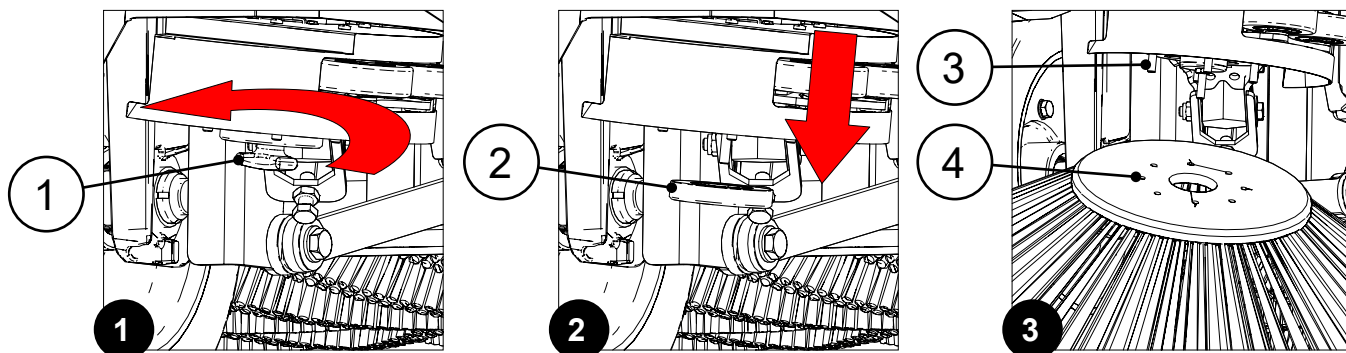

7. Fix the brush to the flange using the knob (1), remembering to put the washer (2) in between the knob and the brush.
8. Once the brush has been fitted, move on to the one on the right.

CLEANING THE BRUSH HEAD BRUSHES (COMBINED VERSION)

Careful cleaning of the brushes in the brush head will ensure better floor cleaning, thus decreasing costs while at the same time improving environmental sustainability and performance.

To clean the brushes on the brush head, proceed as follows:

CAUTION: it is recommended to wear the appropriate PPE (Personal Protective Equipment), suitable for the work to be carried out.

1. Open the left inspection door (1) (Fig.1).
2. Remove the knobs (2) that secure the front brush support (Fig.2).
3. Extract the front brush support (3) from the brush head (Fig.3).

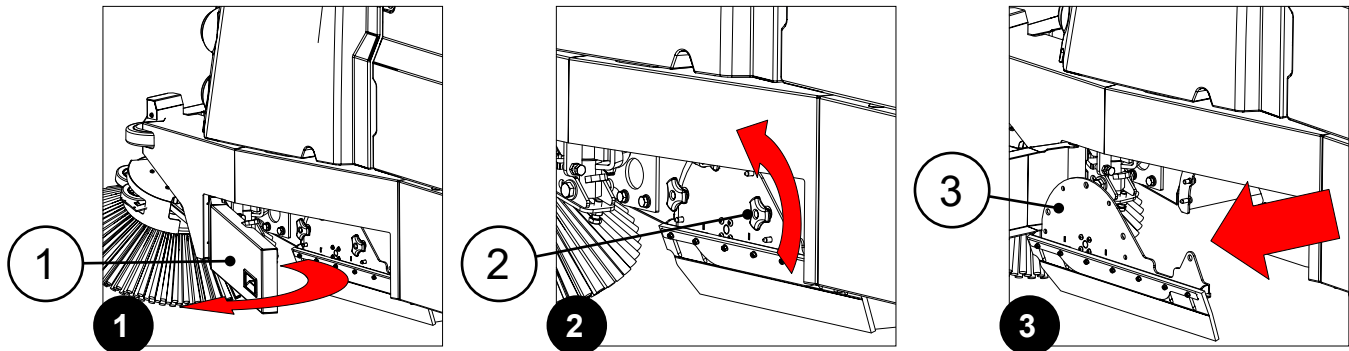

4. Remove the knobs (4) that secure the front brush support (5) (Fig.4).
5. Extract the front brush support (5) from the brush head (Fig.5).
6. Extract the brush (6) from the brush head body (Fig.6).

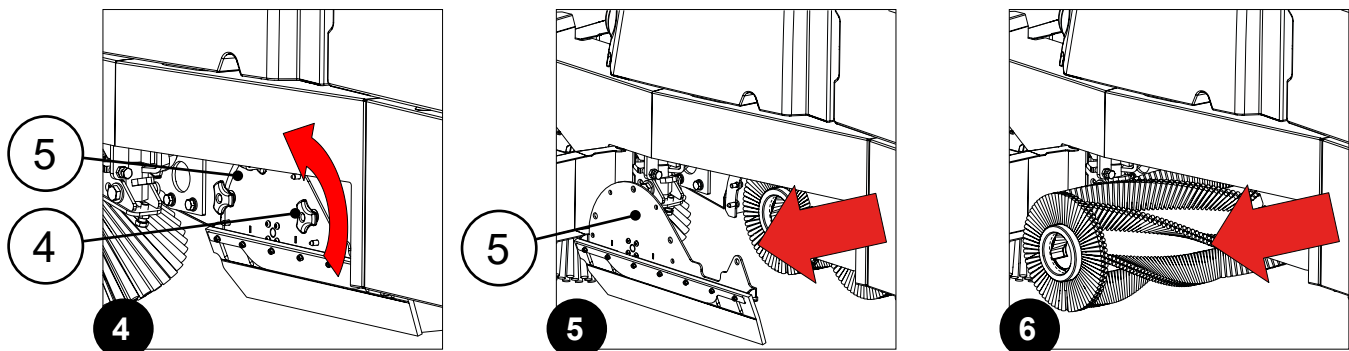

7. Clean the brush under a stream of running water to remove any impurities from its bristles.

i **N.B.:** check the wear of the bristles and replace the brushes if they are excessively worn (the bristle length must not be less than 15 mm; this measurement is indicated on the brush by the yellow band), see [“REPLACING THE SWEEPING BRUSH HEAD BRUSHES \(COMBINED VERSION\)”](#) on page 151.

8. After cleaning, refit the brush, see [“ASSEMBLY OF BRUSHES \(COMBINED VERSION\)”](#) on page 57

i **N.B.:** you are advised to invert the front and rear brushes every day.

! **ATTENTION:** If the brushes are not new, and have deformed bristles, it is better to reassemble them in the same position in order to prevent the different inclination of the bristles from overloading the brush motor, as well as to prevent excessive vibrations.

9. Close the left inspection door.
10. Repeat the operation just performed on the right side as well.

CLEANING THE DEBRIS HOPPER VACUUM FILTER (COMBINED VERSION)

Thorough cleaning of the vacuum filter guarantees enhanced efficiency and a longer working life for the vacuum motor. To clean the filter, proceed as follows:

1. Go to the front of the machine and using the moulded handles (1), remove the vacuum filter cover casing (2) (Fig.1).
2. Place the cover gently on the ground (2).
3. Release by turning the retaining levers (3) anti-clockwise (Fig.2).
4. Using the handle (4) turn the vacuum filter cover (5) to the maintenance position (Fig.3).

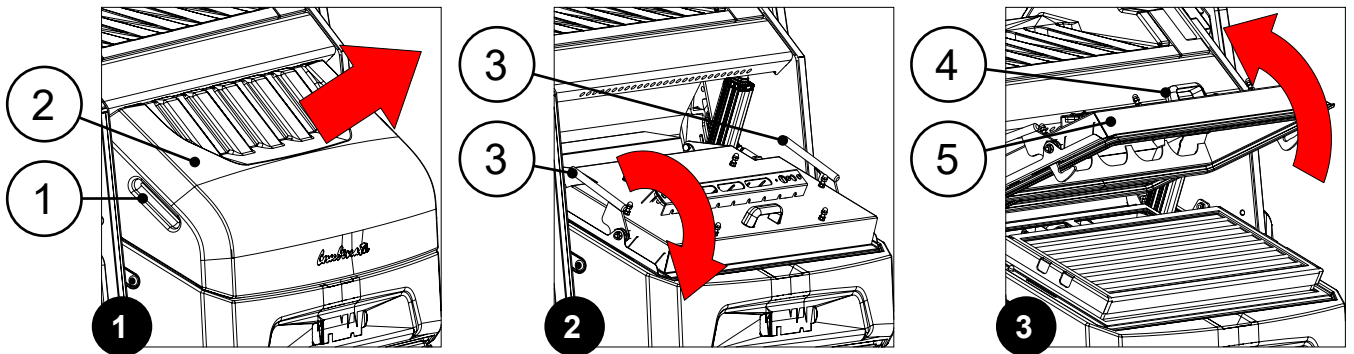

5. Remove the filter press frame (6) (Fig.4).
6. For machine versions with the panel filter, remove the vacuum filter (7) (Fig.5).
7. For machine versions with the bag filter, remove the vacuum filter (8) (Fig.6), taking care to disconnect the connector in the filter-shaker from the connector in the machine's electrical system, before removing it completely.

i N.B.: if the vacuum filter is made of fabric, place it on a surface that can support it in a safe manner.

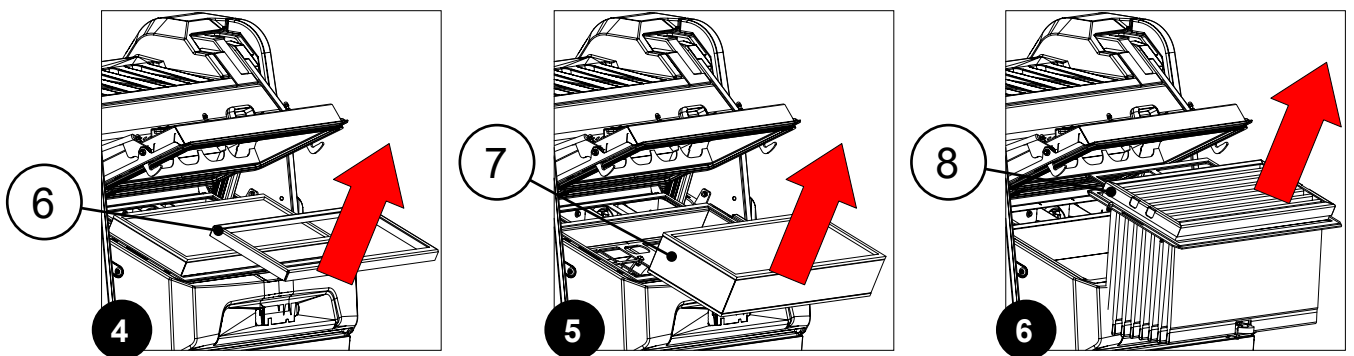

8. Clean the vacuum filter.

i N.B.: if necessary, clean the vacuum filter with an air jet from inside, facing outwards, and kept at a distance of more than 20cm.

i N.B.: if necessary, clean the vacuum filter with a vacuum cleaner.

i N.B.: check to ensure that it is in good condition; where this is not the case, please contact the FIMAP service centre of reference or the nearest one for immediate replacement.

9. When the filter is clean, refit it by following the above steps in reverse order.

CLEANING THE DEBRIS HOPPER (COMBINED VERSION)

Careful cleaning of the debris hopper will ensure better floor cleaning, thus decreasing costs while at the same time improving environmental sustainability and performance.

To clean the debris hopper proceed as follows:

1. Grasp the handle (1) and turn the battery compartment lid (2) to its maintenance position (**Fig.1**).

 **ATTENTION:** to prevent the lid from turning, insert the retainer (3) into the slot (4) (**Fig.2**).

 **ATTENTION:** the following operations must be carried out by qualified personnel. An incorrect connection of the connector may cause a malfunction of the device.

2. Connect the battery charger cable connector (5) to the connector on the power cable coming from the battery box (**Fig.3**).

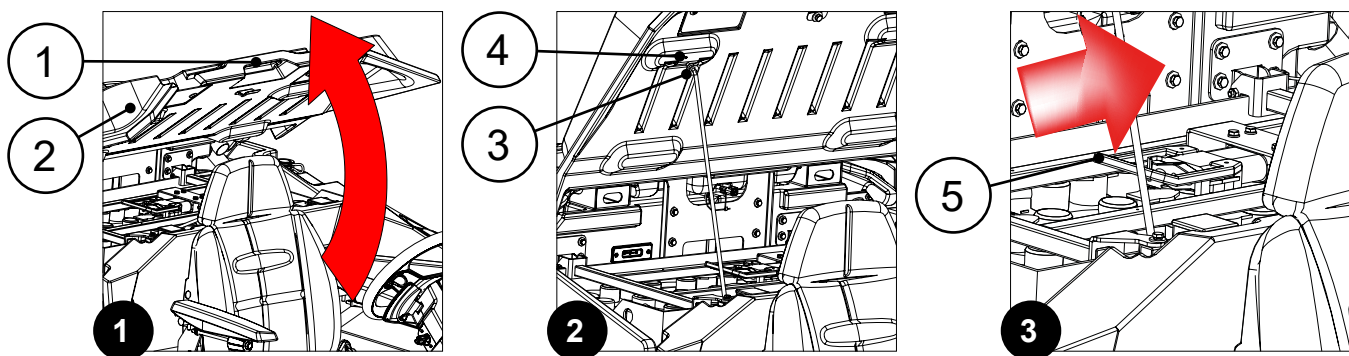

3. Grasp the battery compartment lid and turn it to its working position.

 **N.B.:** release the retainer before turning the lid.

4. Sit on the driver's seat.
5. Insert the key (6) into the slot (7) on the right side of the column (**Fig.4**).
6. Turn on the machine and turn the key (6) a quarter turn clockwise (**Fig.5**).
7. Take the machine to the designated maintenance and cleaning location.

 **N.B.:** the place designated for this operation must comply with current regulations concerning safety at work and current environmental protection regulations.

8. Activate the filter shaker by pressing the button "FILTER SHAKER CONTROL" (8) on the instrument panel (**Fig.6**).

 **ATTENTION:** Do not keep the switch (8) pressed longer than ten seconds; repeat this operation two or three times.

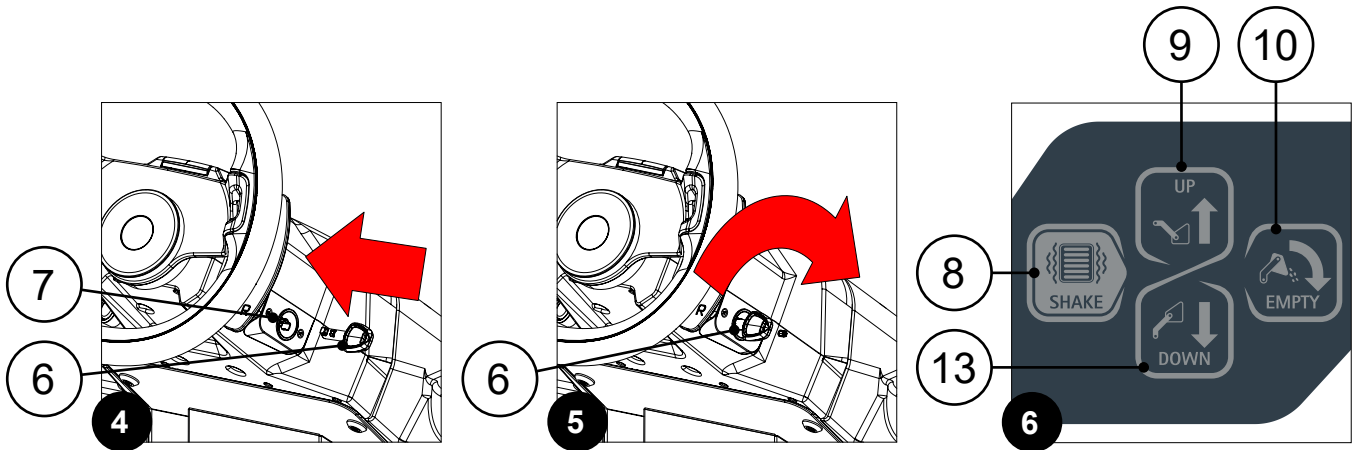

9. Check that there are no objects near the front of the machine that could be hit while rotating the debris hopper.
10. Raise the debris hopper into the maintenance position by pressing the "MOVE DEBRIS HOPPER UPWARDS" button (9) on the instrument panel (**Fig.6**).
11. Bring the machine close to the dirty water drainage hole, ensuring that the debris hopper is fully inside the drainage area.

⚠ WARNING: reduce the machine movement speed when the debris hopper is lifted off the ground.

⚠ WARNING: avoid machine movement when the debris hopper is lifted off the ground on a slope.

⚠ WARNING: do not activate the filter shaker while the debris hopper is lifted off the ground.

12. When the debris hopper is in the cleaning position, stop the machine and rotate the debris hopper into the unloading position. Press the "DEBRIS HOPPER ROTATION" button (10) on the control panel (**Fig.6**).
13. When the debris hopper is fully rotated, turn off the machine, by turning the key (6) a quarter turn anti-clockwise (**Fig.7**).
14. Get off the machine.

⚠ CAUTION: do not position your foot above the side brush head carter while the machine is descending.

15. Remove the "DEBRIS HOPPER ROTATION STOP" (11) on the right side of the machine (**Fig.8**).
16. Insert the stop (11) in the safety position (**Fig.9**).

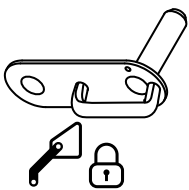

⚠ WARNING: for your own safety, never carry out maintenance on the debris hopper without the stop (11) in the safe position.

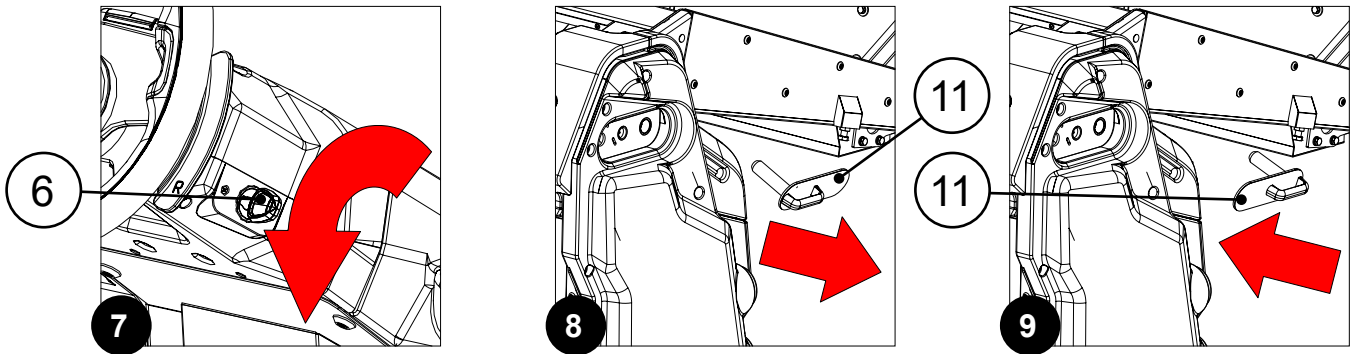

17. Clean the inside of the hopper with a jet of water.
18. When the inside of the debris hopper is clean and dry, remove the debris hopper rotation stop (11) (Fig.10).
19. Insert the stop (11) in the working position (Fig.11).

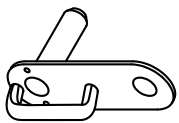

i **N.B.:** the rotation of the debris hopper is only possible if the pin (11) is inserted correctly into the working position.



20. Sit on the driver's seat.
21. Bring the main switch to position "I" by turning the key (9) a quarter turn clockwise (Fig.12).

! **WARNING:** once the machine has been turned on, the debris hopper will automatically rotate into the working position; take care to ensure that there are no objects or people near the debris hopper during this operation.

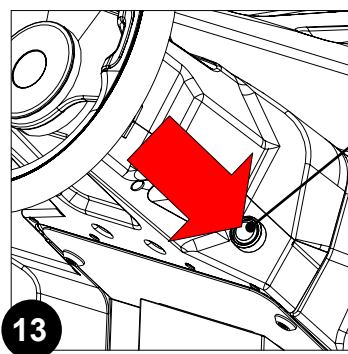
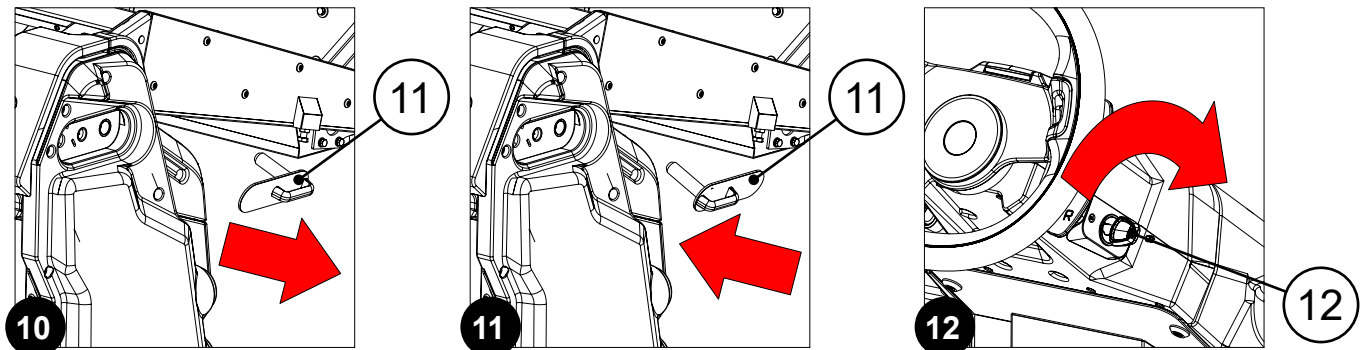

22. Lower the debris hopper whilst simultaneously pressing the "MOVE DEBRIS HOPPER DOWN" button (13) on the control panel (Fig.6) and the "OPERATOR PRESENCE" button (14) on the left side of the steering column (Fig.13).
23. When the debris hopper is in the working position, switch off the machine, turn the key (9) a quarter turn anti-clockwise (Fig.8).

EXTRAORDINARY MAINTENANCE WORK

Before carrying out any extraordinary maintenance operations, proceed as follows:

1. Take the machine to the maintenance area.



N.B.: the place designated for this operation must comply with current regulations concerning safety at work and current environmental protection regulations.

2. Sit on the driver's seat.
3. Insert the key (1) into the slot (2) on the right side of the column (**Fig.1**).
4. Turn on the machine and turn the key (1) a quarter turn clockwise (**Fig.2**).
5. Press the button (3) present on the control panel (**Fig.3**) to activate the maintenance function, see "[SERVICE FUNCTION](#)" on page 86.

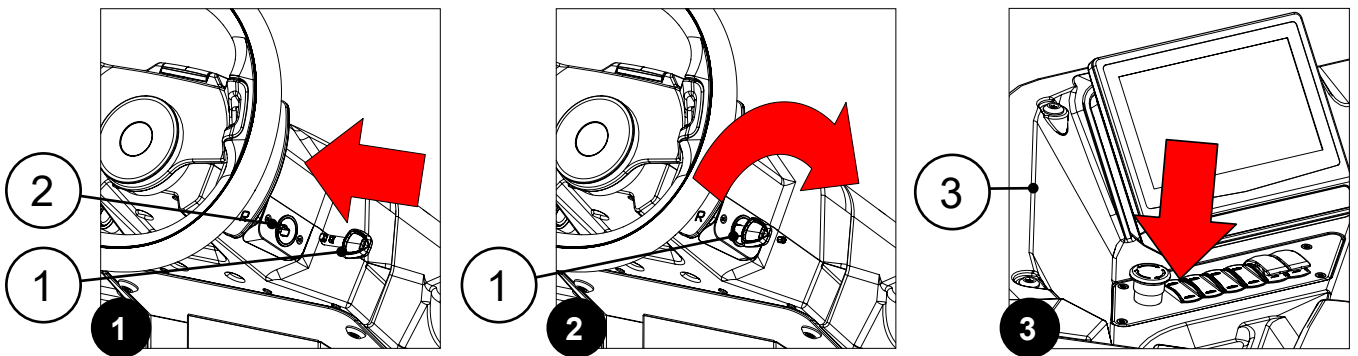

i **N.B.:** once the maintenance sequence has been activated, it is not possible to activate other functions or move the machine.

! **CAUTION:** make sure that no people or objects are in the machine's vicinity during this operation.

6. Bring the main switch to the "0" position by making a quarter turn anti-clockwise with the key (1) (**Fig.4**).
7. Remove the key from the instrument panel.
8. Get off the machine.
9. Remove the key from the instrument panel.
10. Get off the machine.

! **CAUTION:** do not position your foot above the side brush head carter while the machine is descending.

11. Grasp the handle (4) and turn the battery compartment carter (5) to its maintenance position (**Fig.5**).

! **ATTENTION:** to prevent the lid from turning, insert the retainer (6) into the slot (7) (**Fig.6**).

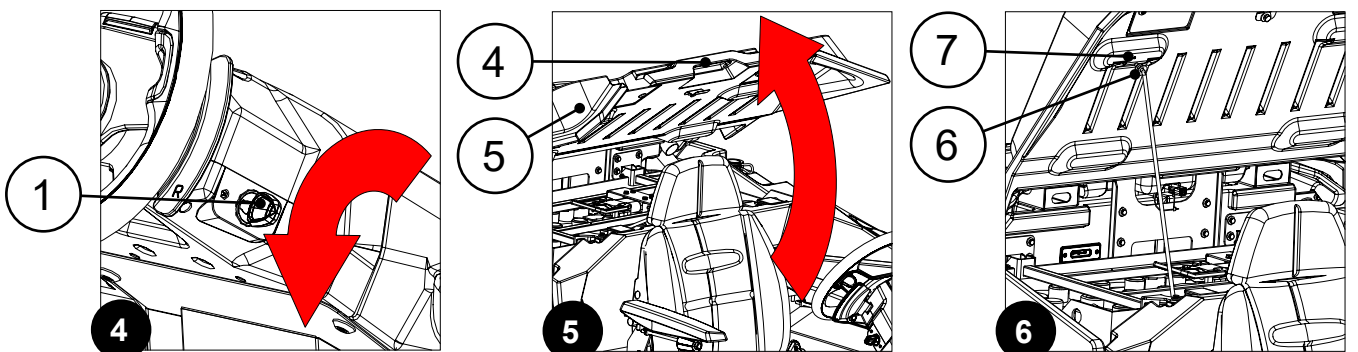

⚠ ATTENTION: the following operations must be carried out by qualified personnel. Incorrect operations could result in machine malfunctions.

12. Disconnect the machine's electrical system wiring connector (8) from the connector on the power cable coming from the battery box (Fig. 7).
13. Grasp the battery compartment lid and turn it to its working position.

i N.B.: release the retainer before turning the lid.

14. Set the detergent solution flow to its OFF position by turning the lever (9) under the operator's seat clockwise (Fig. 8).

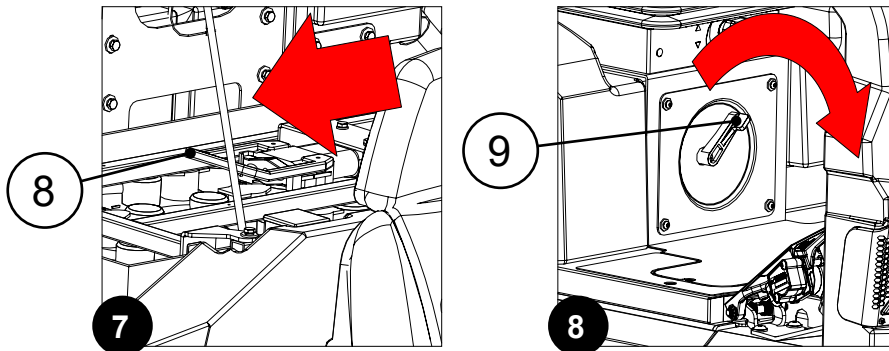

⚠ CAUTION: it is recommended to wear the appropriate PPE (Personal Protective Equipment), suitable for the work to be carried out.

REPLACEMENT OF BRUSH HEAD DRIVE BRUSHES OR DISCS (DISCOID SCRUBBING VERSION)

Ensuring the brush or the drive disc on the brush head is intact will ensure better floor cleaning, thus decreasing costs while at the same time improving environmental sustainability and performance.

To replace the brush or the drive disc on the brush head, using the brush uncoupling function, do the following:

1. Grasp the handle (1) and turn the battery compartment lid (2) to its maintenance position (Fig.1).

⚠ ATTENTION: to prevent the lid from turning, insert the retainer (3) into the slot (4) (Fig.2).

⚠ ATTENTION: the following operations must be carried out by qualified personnel. An incorrect connection of the connector may cause a malfunction of the device.

2. Connect the battery charger cable connector (5) to the connector on the power cable coming from the battery box (Fig.3).

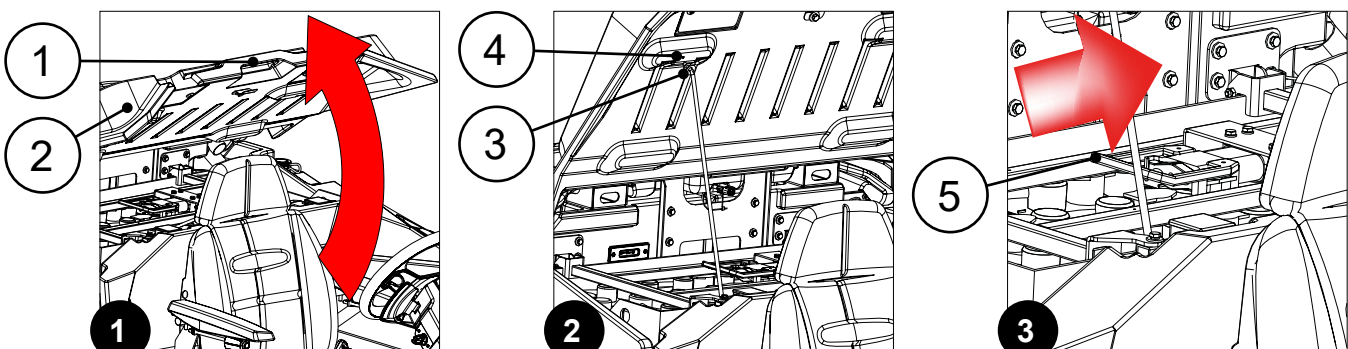

3. Grasp the battery compartment lid and turn it to its working position.

i **N.B.:** release the retainer before turning the lid.

4. Sit on the driver's seat.

5. Insert the key (6) into the slot (7) on the right side of the column (**Fig.4**).

6. Turn on the machine and turn the key (6) a quarter turn clockwise (**Fig.5**).

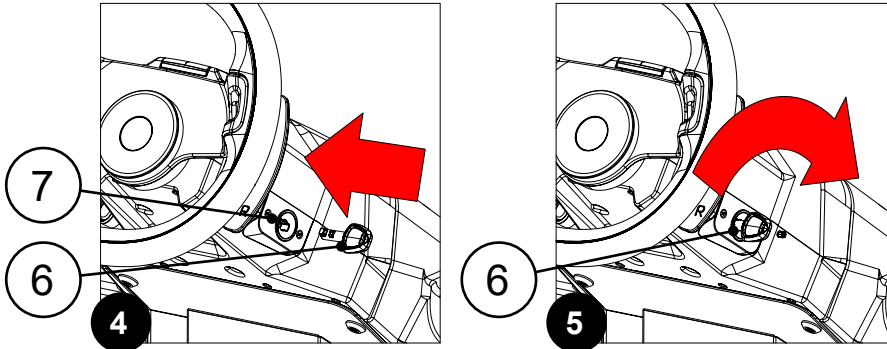

7. Activate the brush release function, see [“BRUSH UNCOUPLING FUNCTION \(DISCOID SCRUBBING VERSION\)” on page 87.](#)

8. After removing worn brushes or drive discs, replace them with new ones.

To replace the brush or the drive disc on the brush head, not using the brush uncoupling function, do the following:

1. Open the left inspection door (1) (**Fig.1**).

2. Set the fastening anchors (2) on the lateral splash guard support to their maintenance position, move them upwards, and turn them a quarter turn clockwise (**Fig.2**).

3. Remove the left side splash guard support (3) located in the brush head (**Fig.3**).

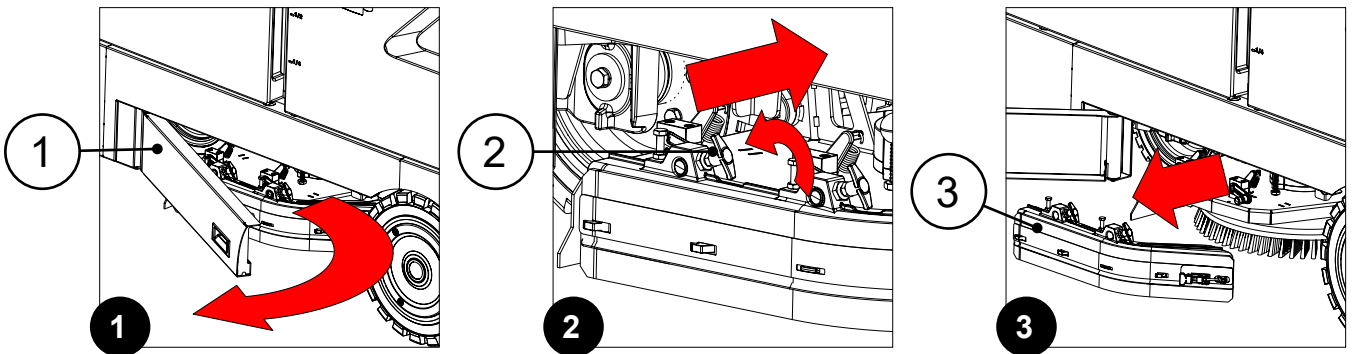

4. Keeping the pin (4) pressed, turn the brush (5) clockwise until it is locked in place (**Fig.4**).

i **N.B.:** turn the brush quickly and firmly so as to push the button on the coupling spring outward until it releases (**Fig.4**).

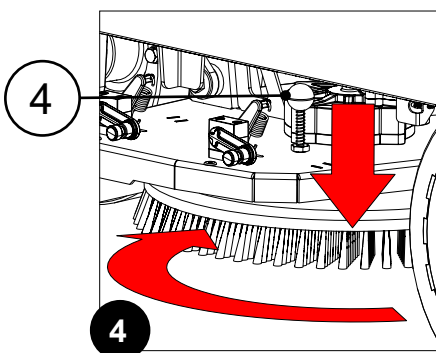

5. After removing worn brushes or drive discs, replace them with new ones.

6. Close the left inspection door.

7. Repeat the operation just performed on the right side as well.

REPLACEMENT OF BRUSH HEAD SIDE SPLASH GUARD (DISCOID SCRUBBING VERSION)

Intact side splash guards will ensure better floor cleaning, thus decreasing costs while at the same time improving environmental sustainability and performance. To replace the side splash guards, do the following:

1. Open the left inspection door (1) (**Fig.1**).
2. Set the fastening anchors (2) on the side splash guard support to their maintenance position, move them upwards, and turn them a quarter turn clockwise (**Fig.2**).
3. Remove the left side splash guard support (3) located in the brush head (**Fig.3**).

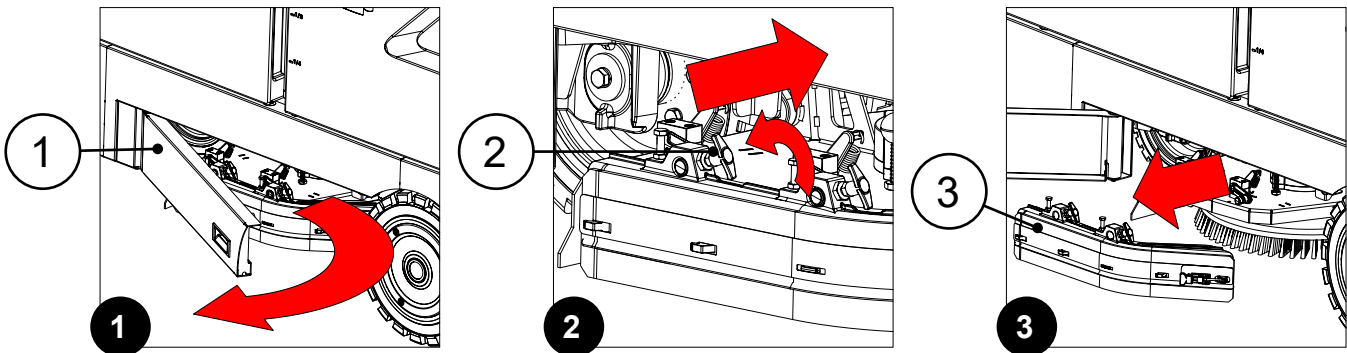

4. Release the retainer (4) on the rubber blade compression plate (5) (**Fig.4**).
5. Remove the rubber blade compression plate (5) and the splash guard (6) from the splash guard support (3) (**Fig.5**).
6. Replace the worn splash guard with the new one.
7. Position the splash guard (6) on the splash guard support (3) and secure it with the rubber blade compression plate (5).
8. Lock the rubber blade compression plate in place by fastening its retainer (4).

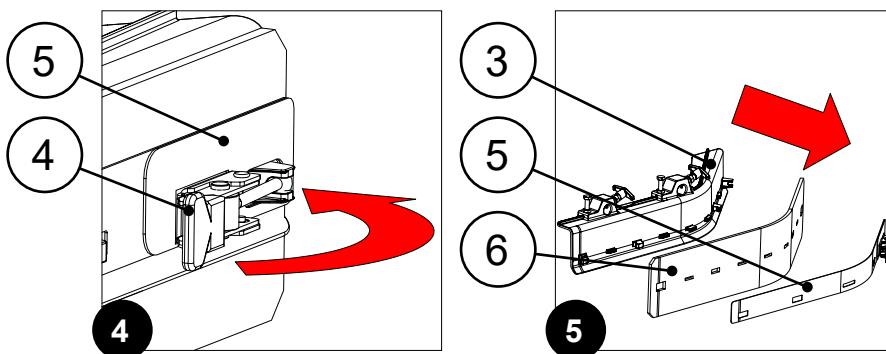

9. Insert the left side splash guard bracket into the brush head.
10. Close the left inspection door.
11. Repeat the operations just carried out for the right lateral splash guard support as well.

REPLACEMENT OF SIDE BRUSH HEAD DRIVE BRUSH OR DISCS (DISCOID SCRUBBING VERSION)

An intact brush will ensure better floor cleaning, thus decreasing costs while at the same time improving environmental sustainability and performance. To replace the side brush, do the following:

1. Moving the brush uncoupling lever (1), rotate the brush anti-clockwise until it stops (**Fig.1**).

i N.B.: turn the brush quickly and firmly so as to push the button on the coupling spring outward until it releases (**Fig.2**).

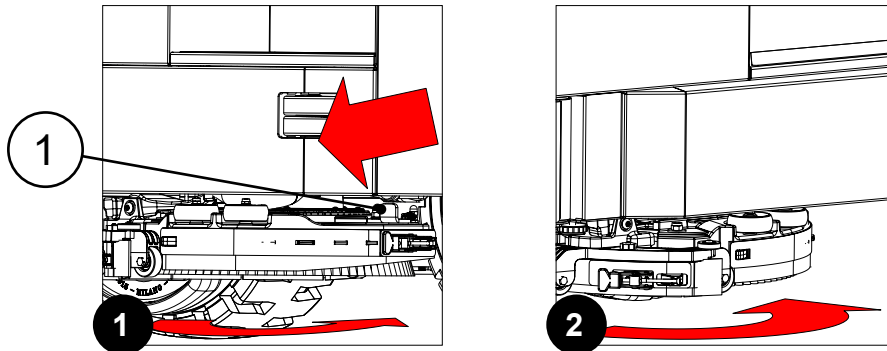

2. Replace the worn brush with a new one.

REPLACEMENT OF SIDE BRUSH HEAD SPLASH-GUARD RUBBER BLADE (DISCOID SCRUBBING VERSION)

An intact splash guard will ensure better floor cleaning, thus decreasing costs while at the same time improving environmental sustainability and performance. To replace the side brush head splash guard, do the following:

1. Release the retainer (1) on the rubber blade compression plate (2) (**Fig.1**).
2. Remove the rubber blade compression plate (2) and the splash guard from the splash guard support (3) (**Fig.2**).
3. Replace the worn splash guard with the new one.
4. Position the splash guard (3) on the splash guard support and secure it with the rubber blade compression plate (2) (**Fig.3**).

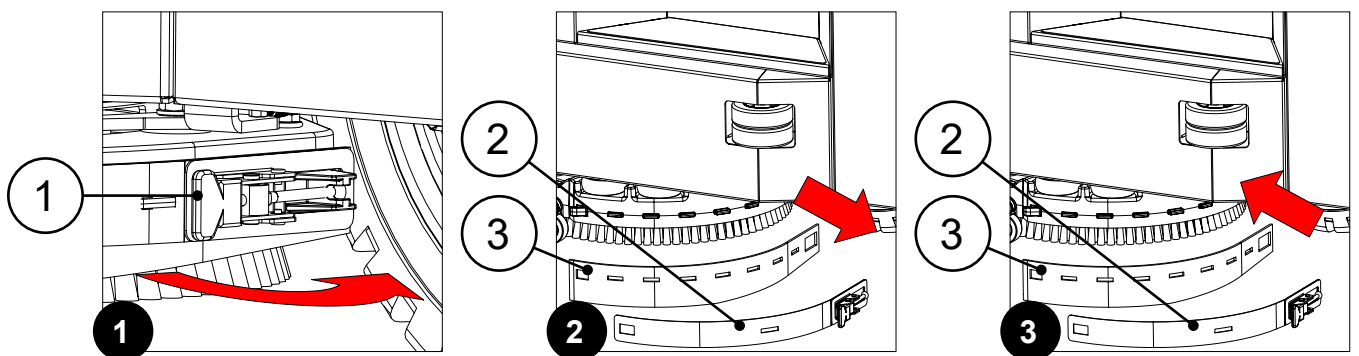

5. Lock the rubber blade compression plate in place by fastening its retainer.

REPLACEMENT OF SIDE BRUSH HEAD SQUEEGEE RUBBER BLADES (DISCOID SCRUBBING VERSION)

Intact side brush head squeegee rubber blades will ensure better floor cleaning, thus decreasing costs while at the same time improving environmental sustainability and performance.

To replace the side brush head squeegee rubber blades, do the following:

1. Open the right inspection carter (1) (**Fig.1**).
2. Turn the squeegee support (2) anti-clockwise (**Fig.2**).
3. Remove the squeegee vacuum hose (3) from the nozzle (4) in the squeegee (**Fig.3**).

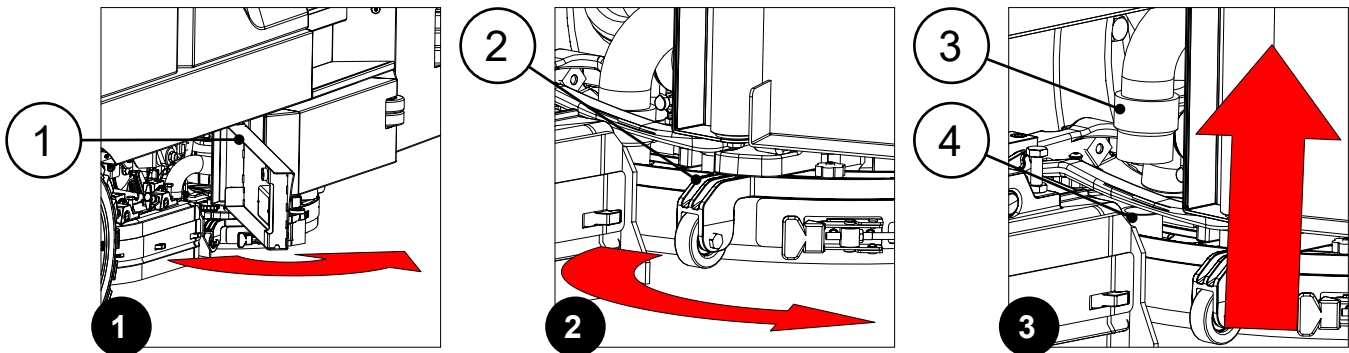

4. Completely unscrew the knobs (5) in the squeegee pre-assembly (**Fig.4**).
5. Remove the squeegee pre-assembly (2) from the slits in the squeegee connector (**Fig. 5**).
6. Remove the rear rubber blade compression plate, and release the retainer (6) at the rear of the squeegee (**Fig.6**).

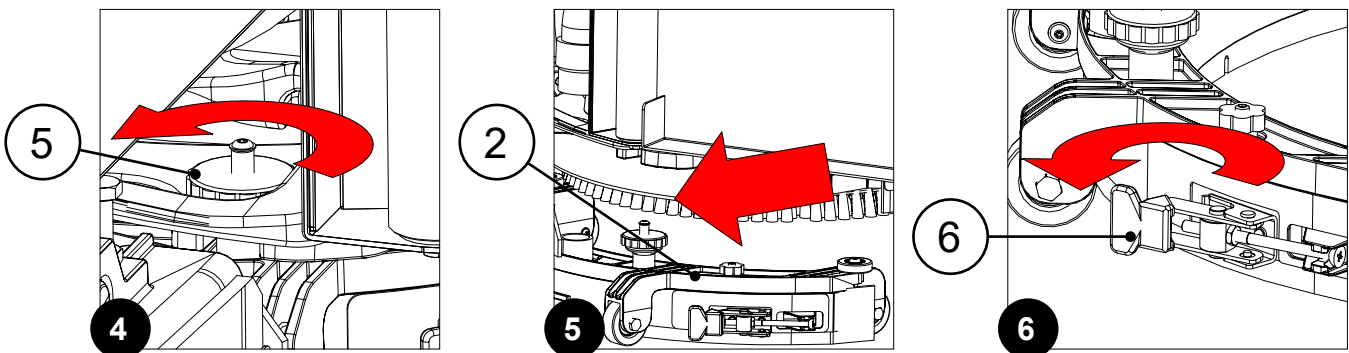

7. Remove the rear rubber blade (7) from the squeegee (**Fig.7**) and replace it with the new one.
8. Completely unscrew the knobs (8) in the squeegee pre-assembly (**Fig.8**).
9. Remove the front rubber blade (9) from the squeegee body's interior (**Fig.9**) and replace it with the new one.

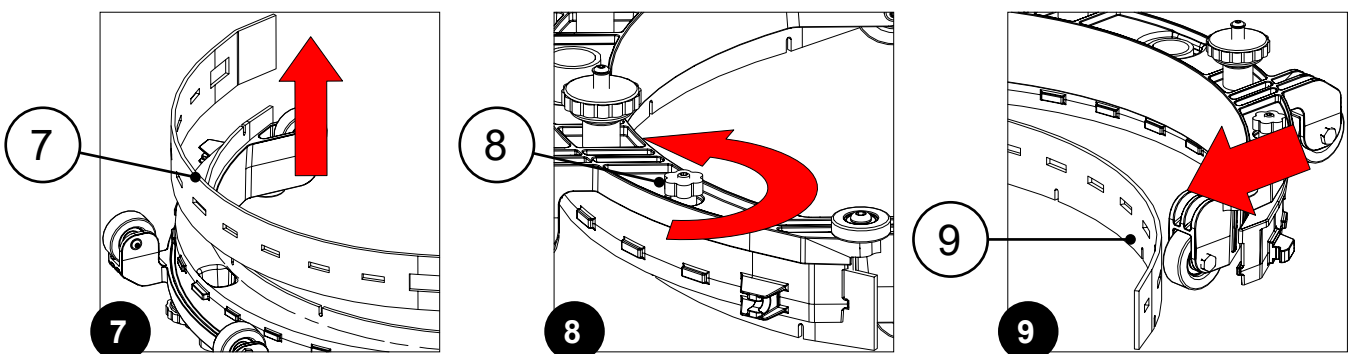

10. Repeat the operations in reverse order to reassemble all the parts.

i **N.B.:** it is advised to replace both squeegee rubber blades in order to ensure good results when drying the floor.

REPLACING THE SQUEEGEE RUBBER BLADES

Intact squeegee rubber blades will ensure better floor cleaning, thus decreasing costs while at the same time improving environmental sustainability and performance.

To replace the squeegee rubber blades, do the following:

1. Remove the vacuum hose (1) from the sleeve (2) in the squeegee (**Fig.1**).
2. Unscrew the knobs (3) in the squeegee pre-assembly (**Fig.2**).
3. Extract the squeegee body the support on the machine (**Fig.3**).

i N.B.: it is advised to replace both squeegee rubber blades in order to ensure good results when drying the floor.

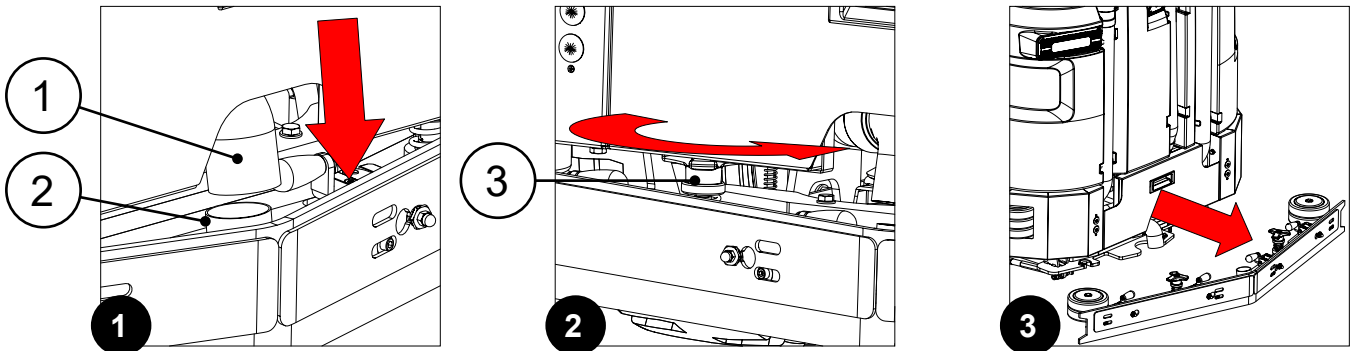

To replace the rear rubber blade, do the following:

- Release the squeegee retainer (4) (**Fig.4**).
- Remove the rubber blade compression plate (5) and the rear rubber blade (6) from the squeegee (7) (**Fig.5**).
- Replace the worn rear rubber blade with the new one.
- Position the rear rubber blade in the squeegee and secure it in place using the rubber blade compression plate (5).
- Block the rubber blade compression plate (5) by fixing the squeegee retainer (4).

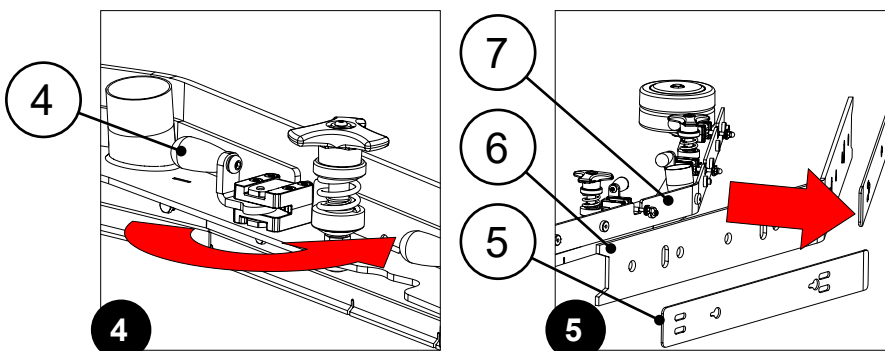

To replace the front rubber blade, do the following:

- Using the appropriate tools, not supplied along with the machine, unscrew the screws (8) securing the rubber blade compression plate (9) to the squeegee (7) (**Fig.6**).
- Remove the rubber blade compression plate (9) and the front rubber blade (10) from the squeegee (7) (**Fig.7**).
- Replace the worn front rubber blade with the new one.
- Position the front rubber blade (10) in the squeegee (7) and secure it in place using the rubber blade compression plate (9).
- Secure the rubber blade compression plate in place by inserting and tightening the screws (8) previously removed.

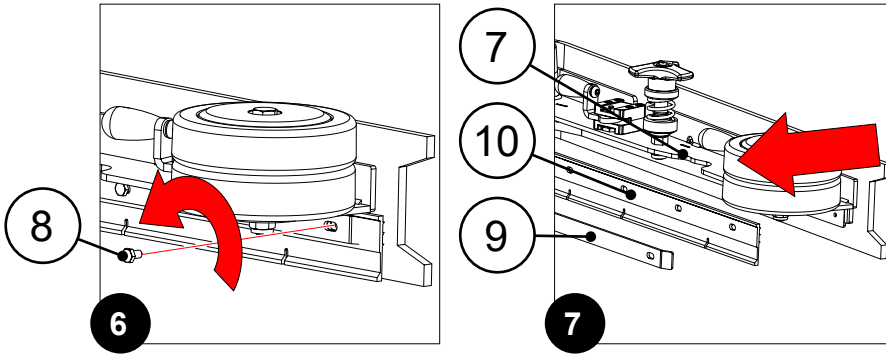

4. Insert the squeegee into the machine.

i **N.B.:** check the adjustment of the rubber blades in the squeegee, if necessary see [“ADJUSTING THE SQUEEGEE RUBBER BLADES”](#) on page 153.

i **N.B.:** it is advised to replace both squeegee rubber blades in order to ensure good results when drying the floor.

REPLACING THE BRUSH HEAD BRUSHES (CYLINDRICAL SCRUBBING VERSION)

To replace the brushes in the brush head, proceed as follows:

1. Open the left inspection door (1) (**Fig.1**).
2. Set the fastening anchors (2) on the side splash guard support to their maintenance position, move them upwards, and turn them a quarter turn clockwise (**Fig.2**).
3. Remove the left side splash guard (3) from the brush head (**Fig.3**).

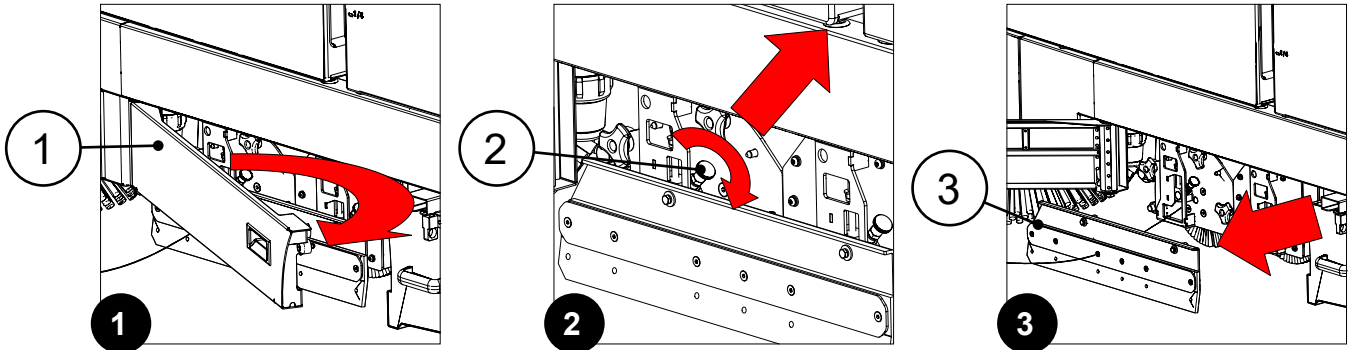

4. Remove the knobs (4) that secure the front brush support (5) (**Fig.4**).
5. Extract the front brush support (5) from the brush head (**Fig.5**).
6. Extract the brush from the brush head body (**Fig.6**).

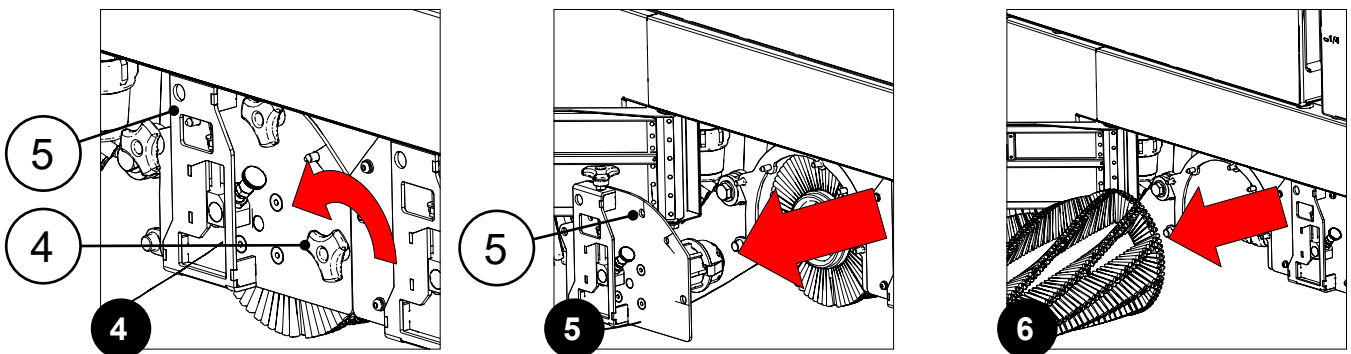

7. Replace the worn brush with a new one.
8. After replacing the front brush, reassemble everything.
9. Repeat the operation just performed on the right side as well.

REPLACEMENT OF BRUSH HEAD SIDE SPLASH GUARD (CYLINDRICAL SCRUBBING VERSION)

Intact side splash guards will ensure better floor cleaning, thus decreasing costs while at the same time improving environmental sustainability and performance. To replace the side splash guards, do the following:

1. Open the left inspection door (1) (**Fig.1**).
2. Set the fastening anchors (2) on the side splash guard support to their maintenance position, move them upwards, and turn them a quarter turn clockwise (**Fig.2**).
3. Remove the left side splash guard (3) from the brush head (**Fig.3**).

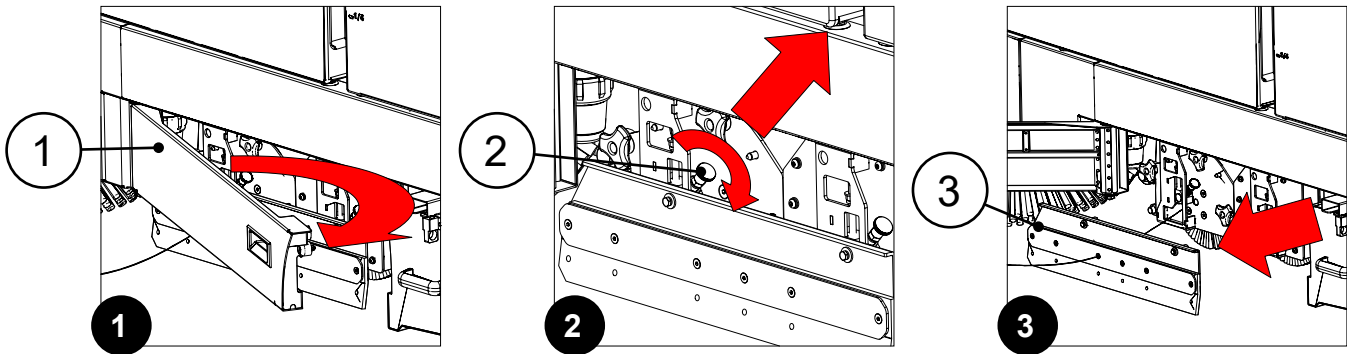

4. Using the appropriate tools, not supplied along with the machine, unscrew the screws (4) securing the rubber blade compression plate (5) to the side splash guard support (3) (**Fig.4**).
5. Remove the rubber blade compression plate (5) and the side splash guard (6) from the side splash guard support (3) (**Fig.5**).
6. Position the new side splash guard on the splash guard support and secure it with the rubber blade compression plate.
7. Secure the rubber blade compression plate in place by tightening the screws previously removed.

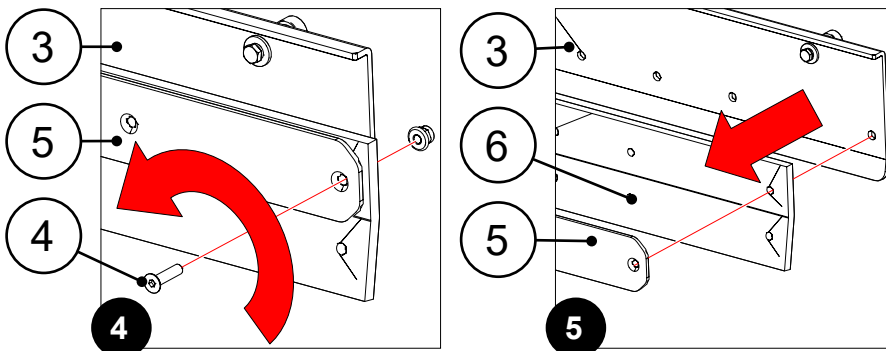

8. Position the left side splash guard (14) in the brush head (**Fig.6**).

⚠ ATTENTION: pay particular attention that the fixing pins (18), are correctly positioned in the holes (19) in the support (**Fig.7**).

9. Set the fastening anchors (13) to their working position, turn them a quarter turn anti-clockwise, and move them downwards (**Fig.8**).

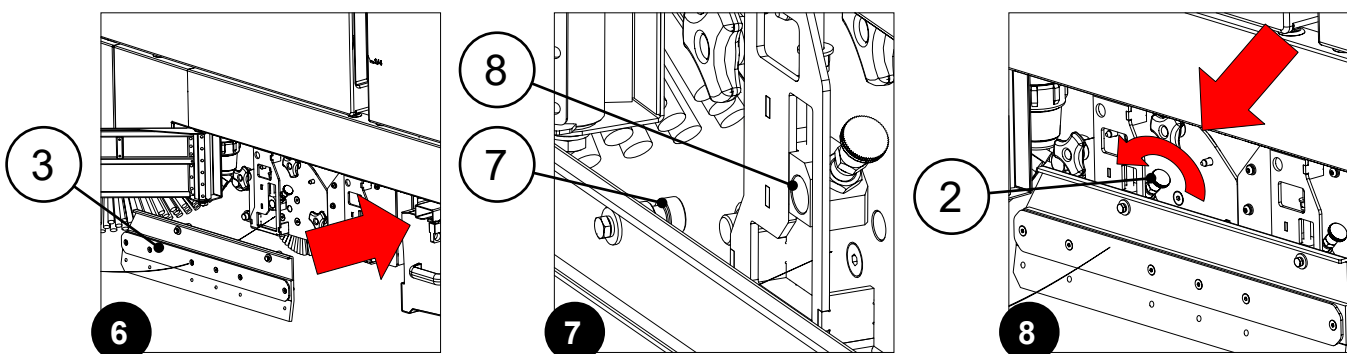

i **N.B.:** check the adjustment of the rubber blades in the squeegee; if necessary, see [“ADJUSTMENT OF BRUSH HEAD SIDE SPLASH GUARD \(CYLINDRICAL SCRUBBING VERSION\)”](#) on page 157.

10. Close the left inspection door.
11. Repeat the operations just carried out for the right lateral splash guard support as well.

REPLACEMENT OF THE SIDE BRUSH (CYLINDRICAL-COMBINED SCRUBBING VERSION)

An intact brush will ensure better floor cleaning, thus decreasing costs while at the same time improving environmental sustainability and performance. To replace the side brush, do the following:

1. Stand on the left front side of the machine.
2. Remove the knob (1) fixing the side brush to the gear motor by rotating the right brush clockwise and the left brush anti-clockwise (**Fig.1**).
3. Remove the washer (2) holding the side brush in place (**Fig.2**).
4. Replace the worn side brush with a new one, making sure to correctly position the pins (3), present in the brush support, in the holes (4), present in the brush (**Fig.3**).

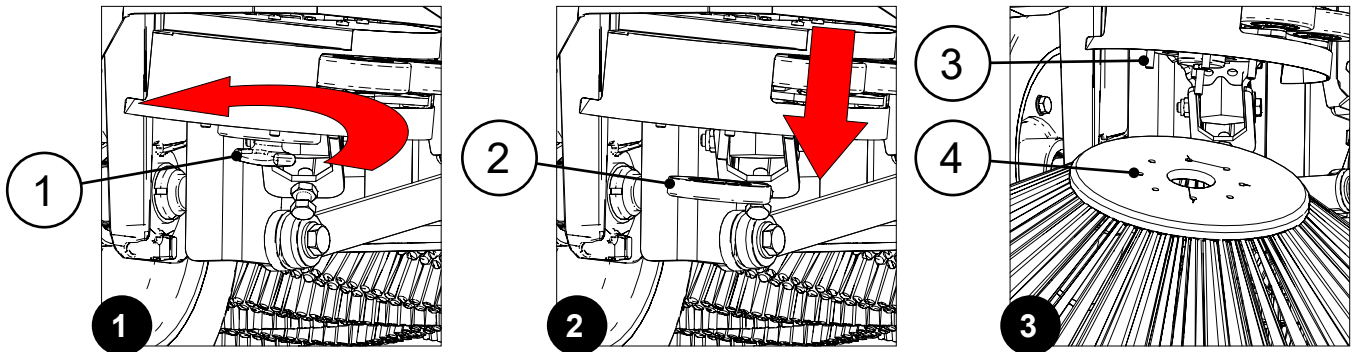

5. Fix the brush to the flange using the knob (1), remembering to put the washer (2) in between the knob and the brush.
6. Once the brush has been fitted, move on to the one on the right.

i **N.B.:** check the adjustment of the side brush, if necessary read [“ADJUSTMENT OF THE SIDE BRUSH \(CYLINDRICAL SCRUBBING VERSION\)”](#) on page 159 or [“ADJUSTING THE SIDE BRUSH \(COMBINED VERSION\)”](#) on page 160.

REPLACING THE SWEEPING BRUSH HEAD BRUSHES (COMBINED VERSION)

Ensuring that the brushes in the brush head are intact will ensure better floor cleaning, thus decreasing costs while at the same time improving environmental sustainability and performance.

To replace the brushes on the brush head, proceed as follows:

CAUTION: it is recommended to wear the appropriate PPE (Personal Protective Equipment), suitable for the work to be carried out.

1. Open the left inspection door (1) (Fig.1).
2. Remove the knobs (2) that secure the front brush support (Fig.2).
3. Extract the front brush support (3) from the brush head (Fig.3).

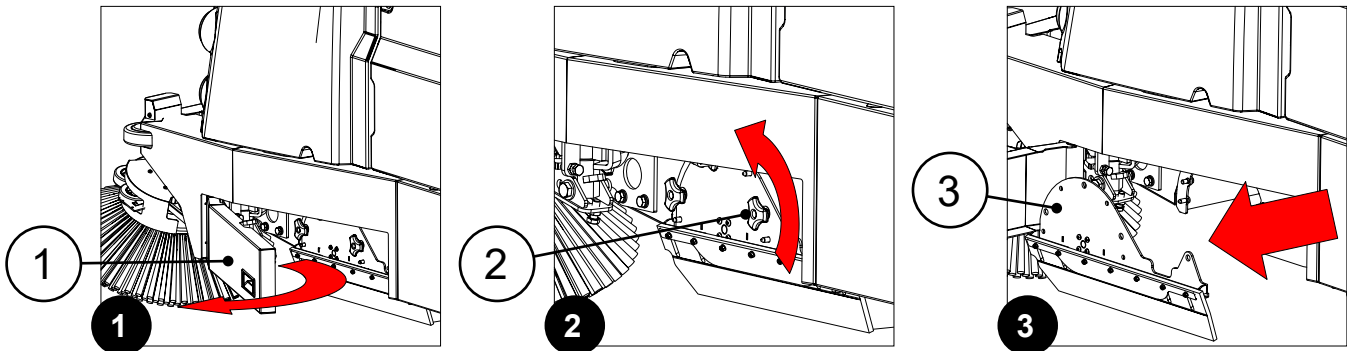

4. Remove the knobs (4) that secure the front brush support (5) (Fig.4).
5. Extract the front brush support (5) from the brush head (Fig.5).
6. Extract the brush (6) from the brush head body (Fig.6).

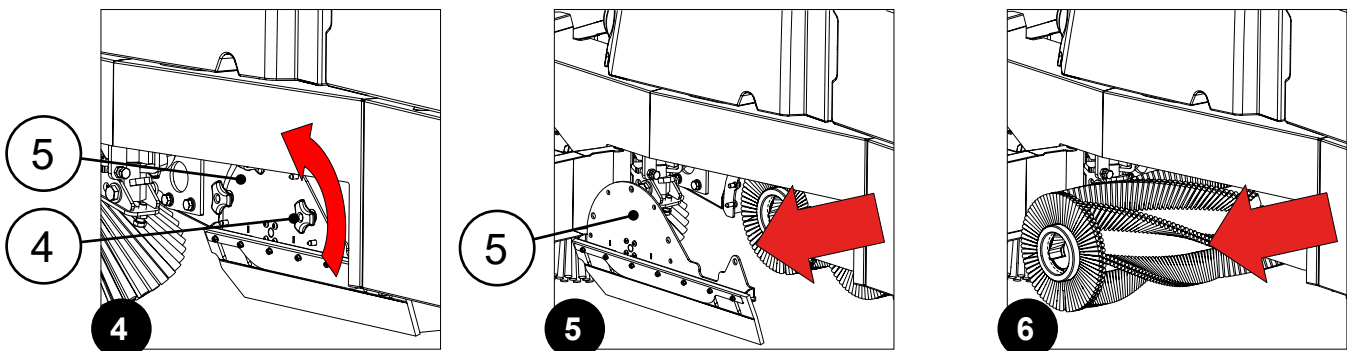

7. Replace the old brush with the new one.
8. Insert the new brush into the tow hook on the brush head body (Fig.7).
9. Rotate the brush until the fastening hooks (6) present in the tow hook (7) (Fig. 8) correctly enter the slots (8) in the brush (Fig.9).

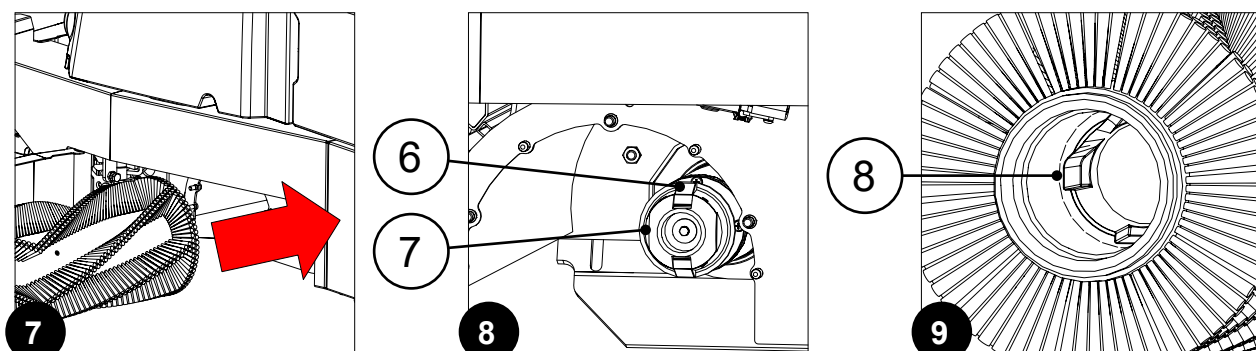

10. Insert the front brush support (5) (**Fig.10**).
11. Rotate the brush until the fastening hooks (9), present in the tow hook (10) fixed to the idle shaft (**Fig. 11**), correctly enter the slots (11) on the brush (**Fig.12**).

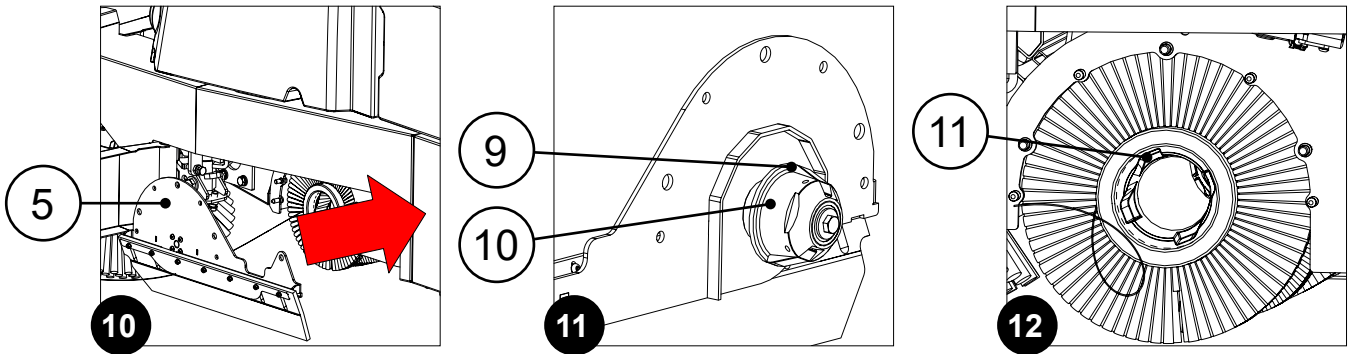

⚠ ATTENTION: pay particular attention that the fixing pins (12), present in the brush head body, are correctly positioned in the holes (13) in the front brush support (**Fig.13**).

12. Fix the front brush support (5) to the brush head body using the knobs (4) previously removed (**Fig.14**).
13. Close the left inspection door (1) (**Fig.15**).
14. Repeat the operations just carried out for the right lateral splash guard support as well.

i N.B.: in order to be installed correctly, the brushes must form an X when viewed from above in the forward direction of movement.

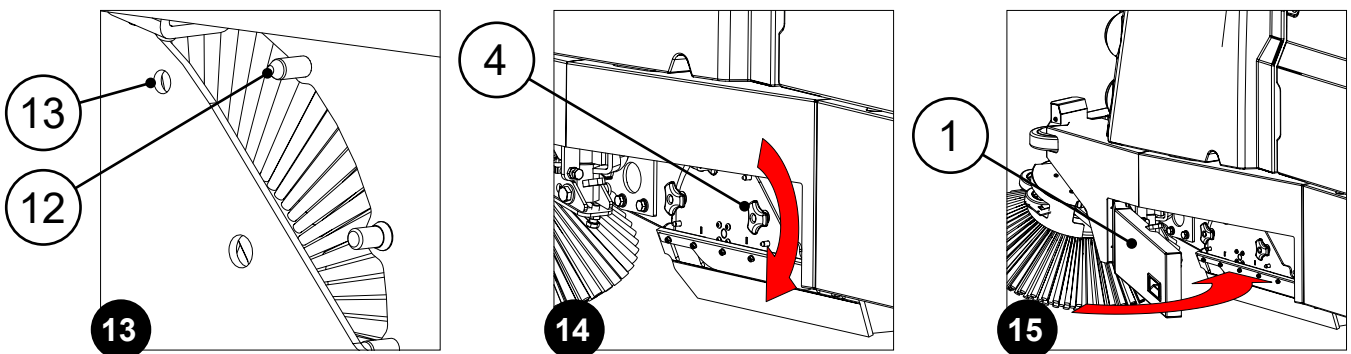

ADJUSTMENT INTERVENTIONS

ADJUSTING THE SQUEEGEE RUBBER BLADES

The precise adjustment of the squeegee rubber blades will ensure better floor cleaning, thus decreasing costs while at the same time improving environmental sustainability and performance.

To regulate the squeegee rubber blades, proceed as follows:

1. Sit on the driver's seat.
2. Insert the key (1) into the slot (2) on the right side of the column (**Fig.1**).
3. Turn on the machine and turn the key (1) a quarter turn clockwise (**Fig.2**).
4. The machine is now operating with the ECO MODE working program, TRANSFER working mode.
5. Activate SCRUBBING-DRYING working mode, see ["DS SELECTOR \(DRIVE SELECT\)" on page 70](#).
6. Press the drive pedal (3) (**Fig.3**) to begin moving the machine.

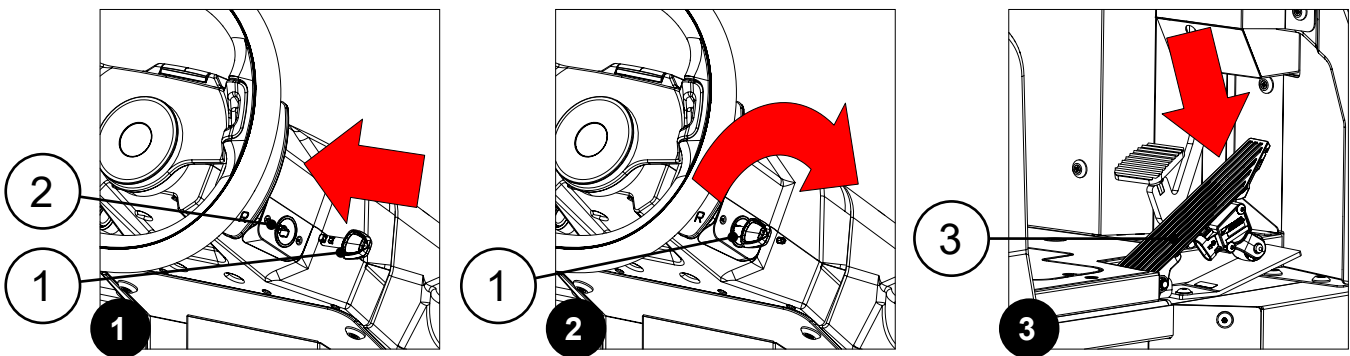

7. Once the brush head and squeegee are in their working positions, set the main switch to its "0" position by turning the key (1) a quarter of a turn anti-clockwise (**Fig.4**).
8. Remove the key from the instrument panel.
9. Get off the machine.

CAUTION: do not position your foot above the side brush head carter while the machine is descending.

10. Grasp the handle (4) and turn the battery compartment carter (5) to its maintenance position (**Fig.5**).

ATTENTION: to prevent the lid from turning, insert the retainer (6) into the slot (7) (**Fig.6**).

ATTENTION: the following operations must be carried out by qualified personnel. Incorrect operations could result in machine malfunctions.

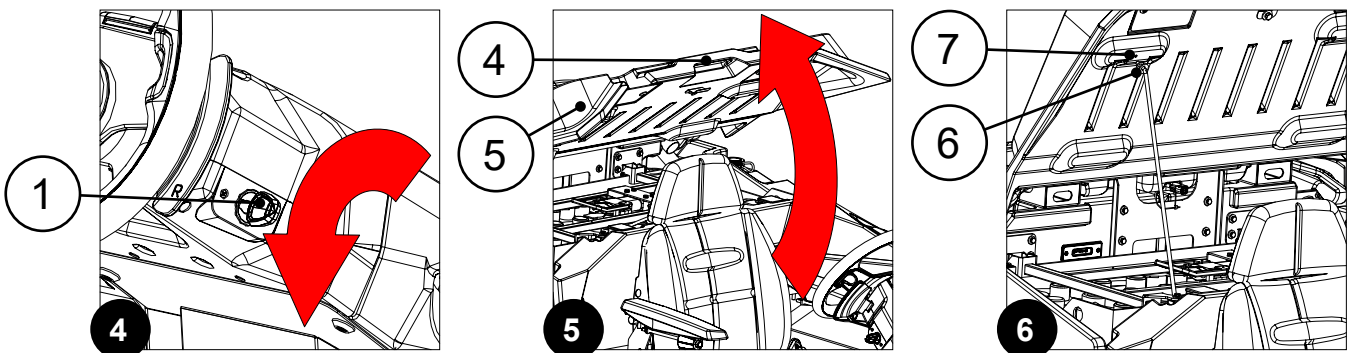

11. Disconnect the machine's electrical system wiring connector (8) from the connector on the power cable coming from the battery box (**Fig. 7**).
12. Grasp the battery compartment lid and turn it to its working position.

i **N.B.:** release the retainer before turning the lid.

i **CAUTION:** it is recommended to wear the appropriate PPE (Personal Protective Equipment), suitable for the work to be carried out.

13. Stand at the back of the machine.

14. Open the inspection footboard (9) (**Fig. 8**), grasp the handle (10), and rotate the footboard towards the outside of the machine.

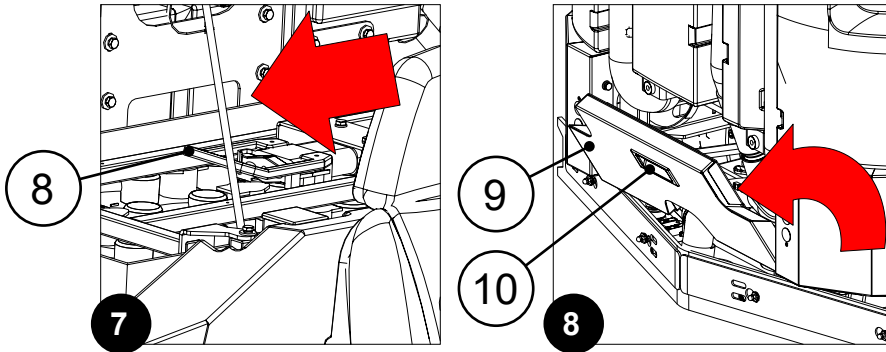

Adjusting the height of the squeegee:

- Release the stopper lever (11) for the squeegee height adjustment knob (12) (**Fig.9**).
- Adjust the height of the rubber blade in relation to the floor by loosening or tightening the knobs (12) (**Fig.10**).

i **N.B.:** **Fig.10** indicates the rotation direction for decreasing the distance between the squeegee support and the floor. This distance can be increased by turning it in the opposite direction.

i **N.B.:** By decreasing the distance between the squeegee support and the floor, the rubber blades present in the squeegee move closer to the floor.

i **N.B.:** The right-hand and left-hand knobs must be rotated the same number of times, so that the squeegee is parallel to the floor when it is working.

i **N.B.:** visually check for proper adjustment by looking at the horizontal level gauge (13) on the squeegee (**Fig.11**). To see the horizontal level gauge (13) close the footboard (9) (**Fig.12**).

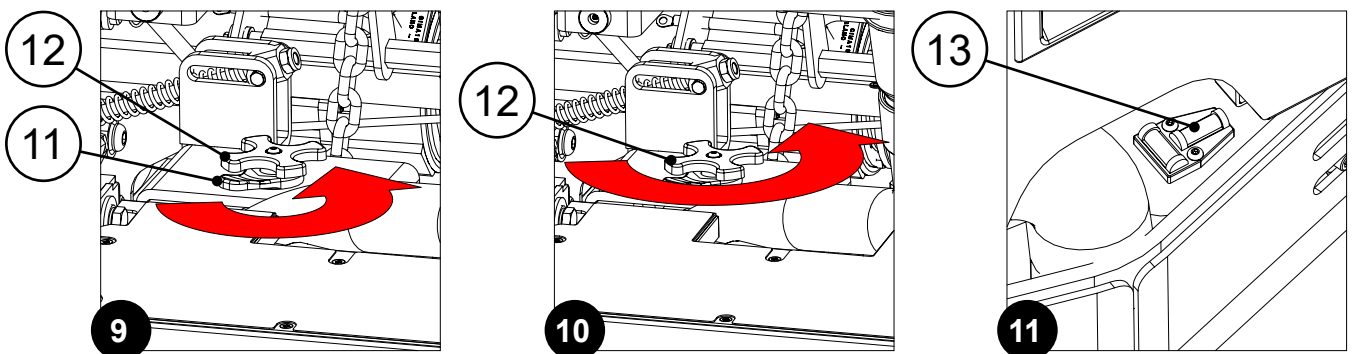

- Once the adjustment has been completed, tighten the retainer lever (11) (**Fig.13**).

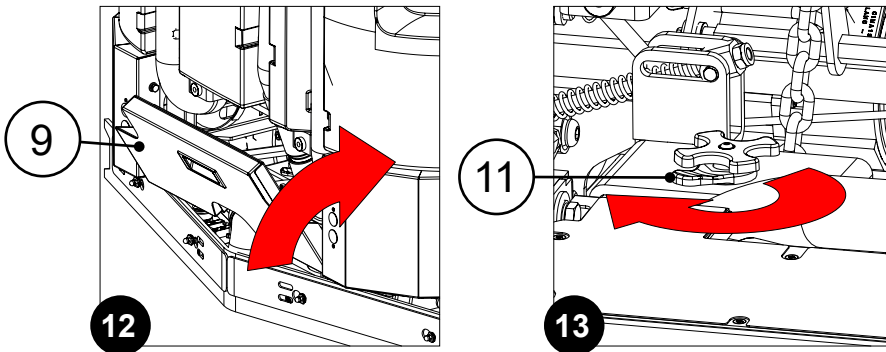

Adjusting the tilt of the squeegee:

- Using the appropriate tools, not included with the machine, loosen the retainer nuts (14) for the squeegee tilt adjustment tie-rod (15) (**Fig.14**).
- To adjust the inclination of the squeegee rubber blades with respect to the floor, tighten or loosen the tie-rod (15) (**Fig.15**) until the squeegee rubber blades are slanted towards the outside evenly along the entire length by about 30° with respect to the floor (**Fig.16**).

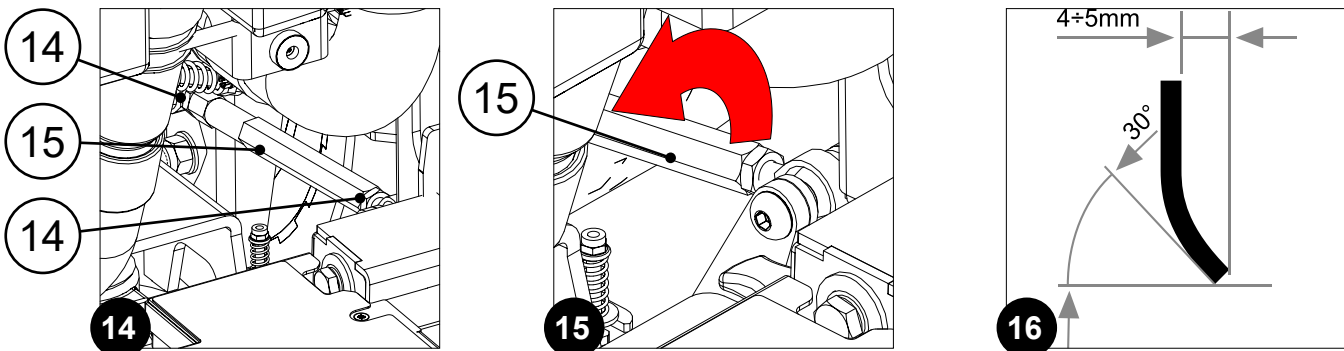

i **N.B.:** **Fig.15** indicates the direction of rotation for tilting the squeegee towards the rear of the machine. Turn it in the opposite direction to rotate the squeegee towards the front of the machine.

i **N.B.:** Check that the adjustment is correct by looking at the horizontal bubble gauge (16) on the squeegee (**Fig.17**).

- Once the adjustment has been completed, tighten the retainer nuts (14) (**Fig.14**).

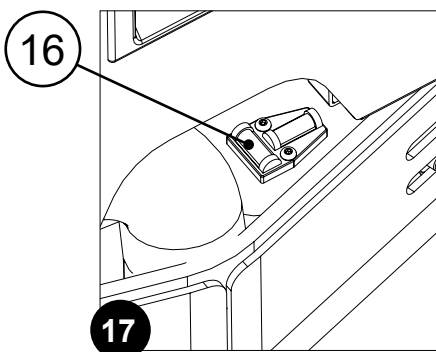

ADJUSTMENT OF BRUSH HEAD SIDE SPLASH GUARD (DISCOID SCRUBBING VERSION)

If the side splash guards of the brush head are not positioned correctly with respect to the floor, they cannot convey the dirty detergent solution towards the squeegee, therefore the height of the splash guard needs to be adjusted.

This operation must be done with the brush head in the work position, proceeding as follows:

1. Sit on the driver's seat.
2. Insert the key (1) into the slot (2) on the right side of the column (**Fig.1**).
3. Turn on the machine and turn the key (1) a quarter turn clockwise (**Fig.2**).
4. The machine is now operating with the ECO MODE working program, TRANSFER working mode.
5. Activate SCRUBBING-DRYING working mode, see "[DS SELECTOR \(DRIVE SELECT\)](#)" on page 70.
6. Press the drive pedal (3) (**Fig.3**) to begin moving the machine.

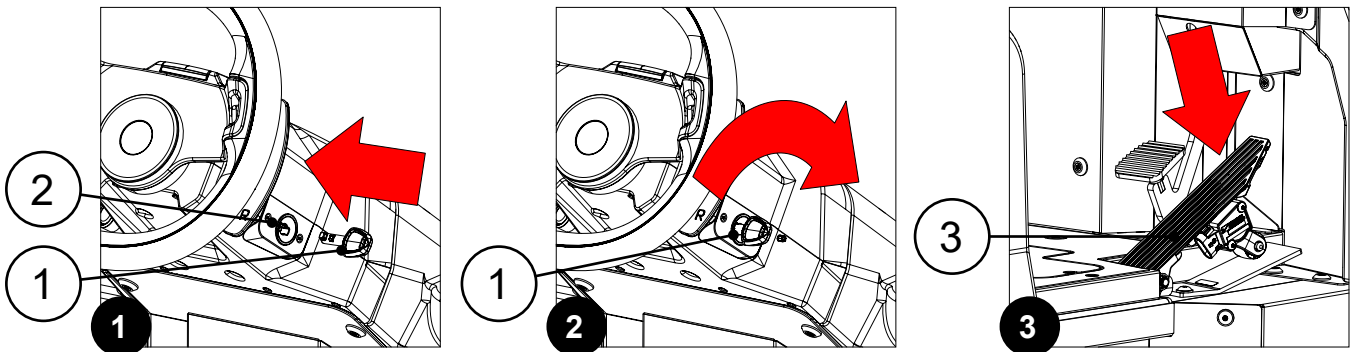

7. Once the brush head and squeegee are in their working positions, set the main switch to its "0" position by turning the key (1) a quarter of a turn anti-clockwise (**Fig.4**).
8. Remove the key from the instrument panel.
9. Get off the machine.

CAUTION: do not position your foot above the side brush head carter while the machine is descending.

10. Grasp the handle (4) and turn the battery compartment carter (5) to its maintenance position (**Fig.5**).

ATTENTION: to prevent the lid from turning, insert the retainer (6) into the slot (7) (**Fig.6**).

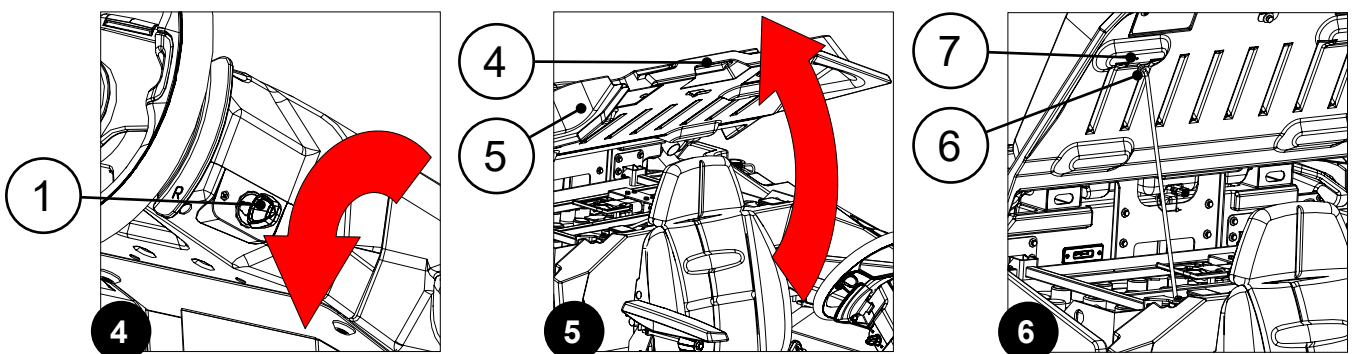

WARNING: the following operations must be carried out by qualified personnel. Incorrect operations could result in machine malfunctions.

11. Disconnect the machine's electrical system wiring connector (8) from the connector on the power cable coming from the battery box (**Fig. 7**).
12. Grasp the battery compartment lid and turn it to its working position.

i **N.B.:** release the retainer before turning the lid.

CAUTION: it is recommended to wear the appropriate PPE (Personal Protective Equipment), suitable for the work to be carried out.

13. Open the left inspection door (9) (**Fig.8**).

14. Using the appropriate tools, not included along with the machine, loosen the retainer nut (10) for the adjustment screw (11) (**Fig.9**).

15. By tightening or loosening the adjustment screw (11), adjust the height of the splash guard in relation to the floor until the splash guard's rubber blade is slanted outwards to the same degree along its entire length, at an angle of about 30° in relation to the floor.

i **N.B.:** Both the front and rear of the splash guard need to be at the same height off the floor.

16. When finished, repeat the operations just carried out for the right lateral splash guard support as well.

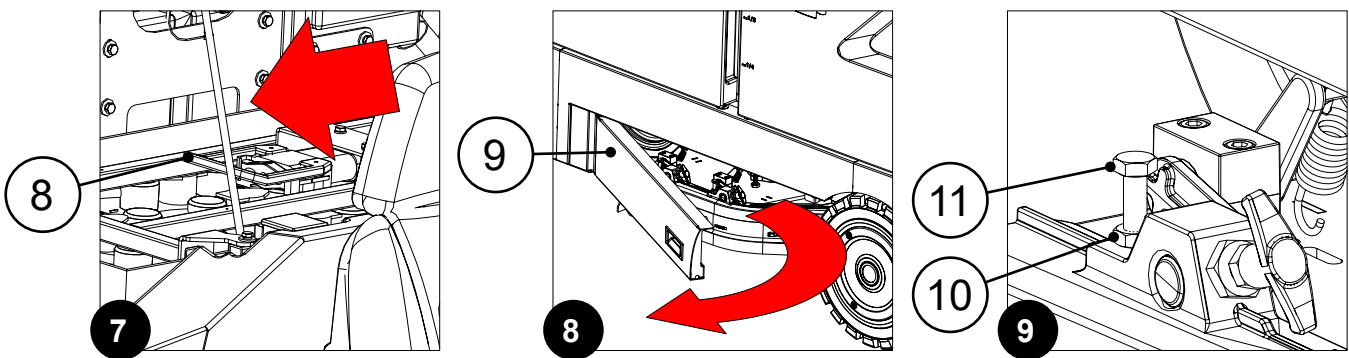

ADJUSTMENT OF BRUSH HEAD SIDE SPLASH GUARD (CYLINDRICAL SCRUBBING VERSION)

If the side splash guards of the brush head are not positioned correctly with respect to the floor, they cannot convey the dirty detergent solution towards the squeegee, therefore the height of the splash guard needs to be adjusted.

This operation must be done with the brush head in the work position, proceeding as follows:

1. Sit on the driver's seat.
2. Insert the key (1) into the slot (2) on the right side of the column (**Fig.1**).
3. Turn on the machine and turn the key (1) a quarter turn clockwise (**Fig.2**).
4. The machine is now operating with the ECO MODE working program, TRANSFER working mode.
5. Activate SCRUBBING-DRYING working mode, see "[DS SELECTOR \(DRIVE SELECT\)](#)" on page 70.
6. Press the drive pedal (3) (**Fig.3**) to begin moving the machine.

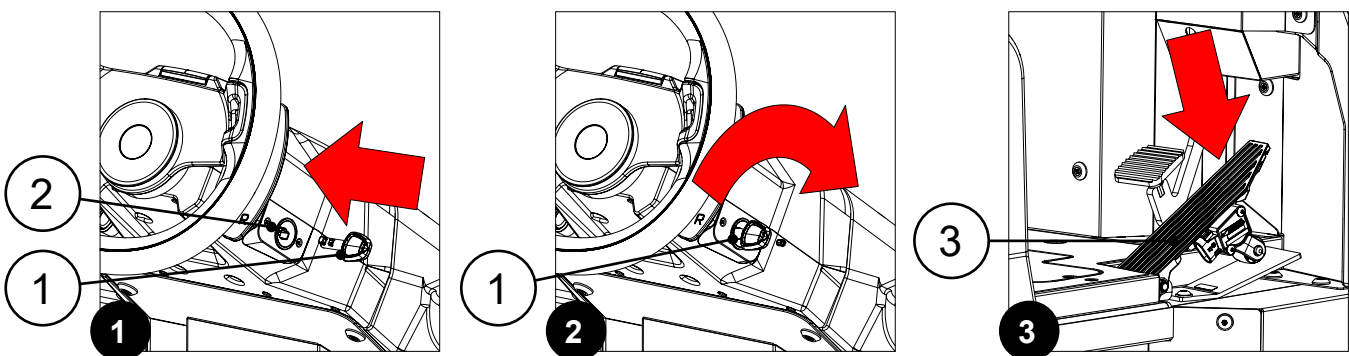

7. Once the brush head and squeegee are in their working positions, set the main switch to its "0" position by turning the key (1) a quarter of a turn anti-clockwise (**Fig.4**).
8. Remove the key from the instrument panel.
9. Get off the machine.



CAUTION: do not position your foot above the side brush head carter while the machine is descending.

10. Grasp the handle (4) and turn the battery compartment carter (5) to its maintenance position (**Fig.5**).



ATTENTION: to prevent the lid from turning, insert the retainer (6) into the slot (7) (**Fig.6**).

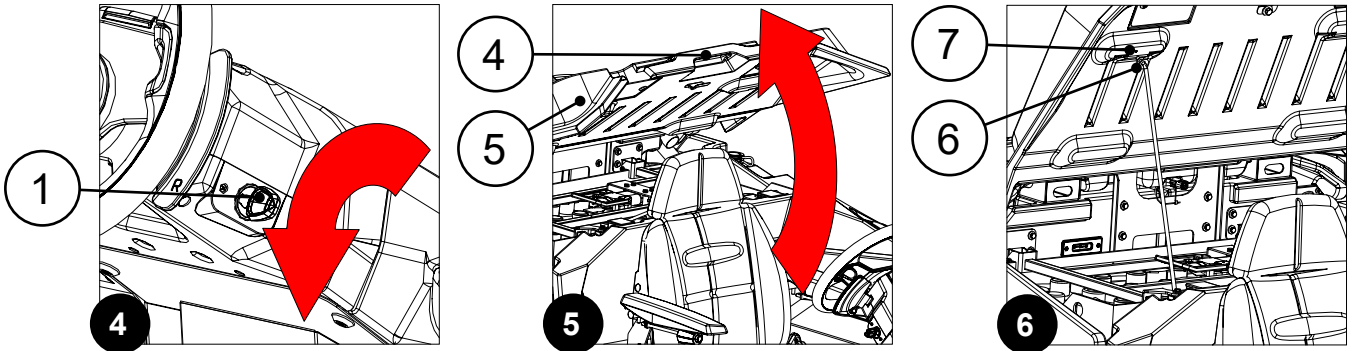

ATTENTION: the following operations must be carried out by qualified personnel. Incorrect operations could result in machine malfunctions.

11. Disconnect the machine's electrical system wiring connector (8) from the connector on the power cable coming from the battery box (**Fig. 7**).
12. Grasp the battery compartment lid and turn it to its working position.



N.B.: release the retainer before turning the lid.



CAUTION: it is recommended to wear the appropriate PPE (Personal Protective Equipment), suitable for the work to be carried out.

13. Open the left inspection door (9) (**Fig.8**).
14. Adjust the height of the splash guard in relation to the floor, screw or unscrew the knob (10) (**Fig. 9**) until the splash guard rubber blade is bent outwards, to the same degree along its entire length, at an angle of around 30° in relation to the floor.



N.B.: Both the front and rear of the splash guard need to be at the same height off the floor.

15. When finished, repeat the operations just carried out for the right lateral splash guard support as well.

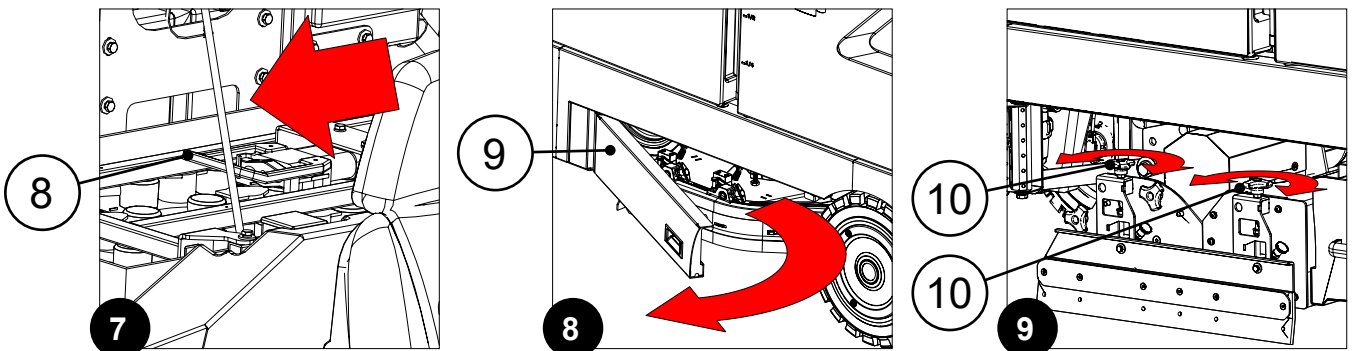

ADJUSTMENT OF THE SIDE BRUSH (CYLINDRICAL SCRUBBING VERSION)

If the side brush is not positioned correctly in relation to the floor, it will not convey the dirt correctly towards the centre of the machine, therefore it is necessary to adjust the vertical angle of the side brush.

This operation must be done with the side brush in the work position, proceeding as follows:

1. Sit on the driver's seat.
2. Insert the key (1) into the slot (2) on the right side of the column (**Fig.1**).
3. Turn on the machine and turn the key (1) a quarter turn clockwise (**Fig.2**).
4. The machine is now operating with the ECO MODE working program, TRANSFER working mode.
5. Activate SCRUBBING-DRYING working mode, see ["DS SELECTOR \(DRIVE SELECT\)"](#) on page 70.
6. Activate the side brushes, see ["SIDE BRUSH \(CYLINDRICAL SCRUBBING VERSION\)"](#) on page 105.
7. Press the drive pedal (3) (**Fig.3**) to begin moving the machine.

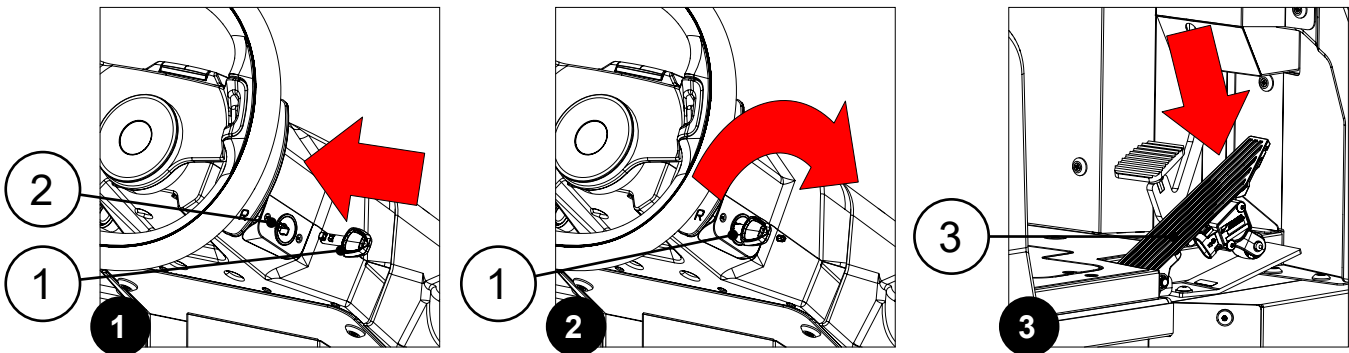

8. Once the brush head and squeegee are in their working positions, set the main switch to its "0" position by turning the key (1) a quarter of a turn anti-clockwise (**Fig.4**).
9. Remove the key from the instrument panel.
10. Get off the machine.

CAUTION: do not position your foot above the side brush head carter while the machine is descending.

11. Grasp the handle (4) and turn the battery compartment carter (5) to its maintenance position (**Fig.5**).

WARNING: to prevent the lid from turning, insert the retainer (6) into the slot (7) (**Fig.6**).

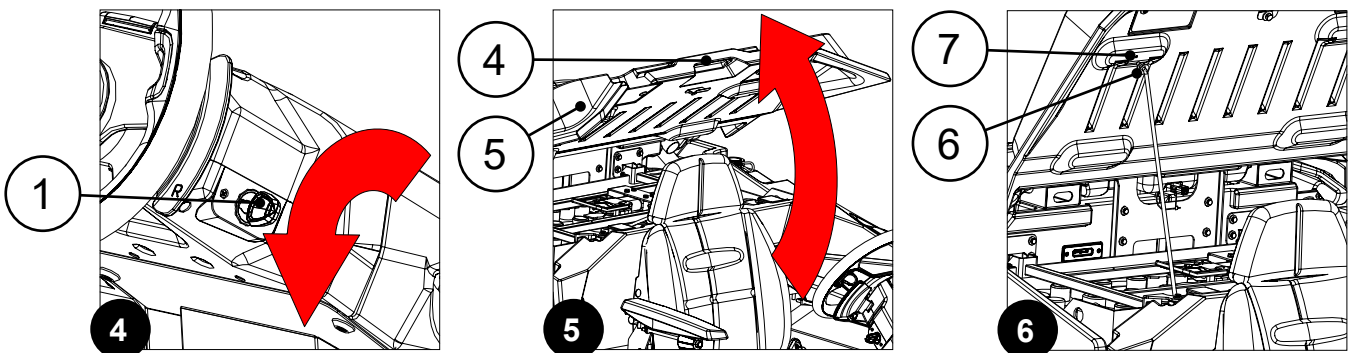

ATTENTION: the following operations must be carried out by qualified personnel. Incorrect operations could result in machine malfunctions.

12. Disconnect the machine's electrical system wiring connector (8) from the connector on the power cable coming from the battery box (**Fig. 7**).

13. Grasp the battery compartment lid and turn it to its working position.

i **N.B.:** release the retainer before turning the lid.

CAUTION: it is recommended to wear the appropriate PPE (Personal Protective Equipment), suitable for the work to be carried out.

14. Go to the front left-hand side of the machine.

15. Using the appropriate tools, not included along with the machine, loosen the retainer nut for the adjustment screw (9) (**Fig.8**).

16. Adjust the angle of the side brush with respect to the floor, screw or unscrew the screw (9) until the bristles of the brush are pressed against the floor by about two centimetres.

17. Once the adjustment is finished, tighten the counter nut and move on to the right side brush.

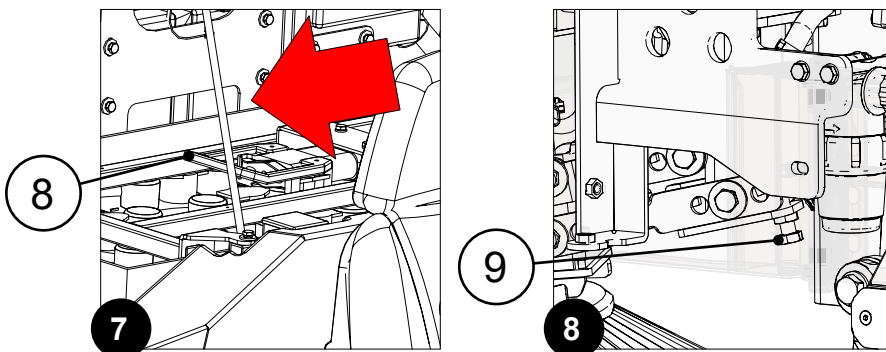

ADJUSTING THE SIDE BRUSH (COMBINED VERSION)

If the side brush is not positioned correctly in relation to the floor, it will not convey the dirt correctly towards the centre of the machine, therefore it is necessary to adjust the vertical angle of the side brush.

This operation must be done with the side brush in the work position, proceeding as follows:

1. Sit on the driver's seat.
2. Insert the key (1) into the slot (2) on the right side of the column (**Fig.1**).
3. Turn on the machine and turn the key (1) a quarter turn clockwise (**Fig.2**).
4. The machine is now operating with the ECO MODE working program, TRANSFER working mode.
5. Activate SWEEPING working mode, see "[DS SELECTOR \(DRIVE SELECT\)](#)" on page 70.
6. Activate the side brushes, see "[SIDE BRUSH \(COMBINED VERSION\)](#)" on page 98.
7. Press the drive pedal (3) (**Fig.3**) to begin moving the machine.

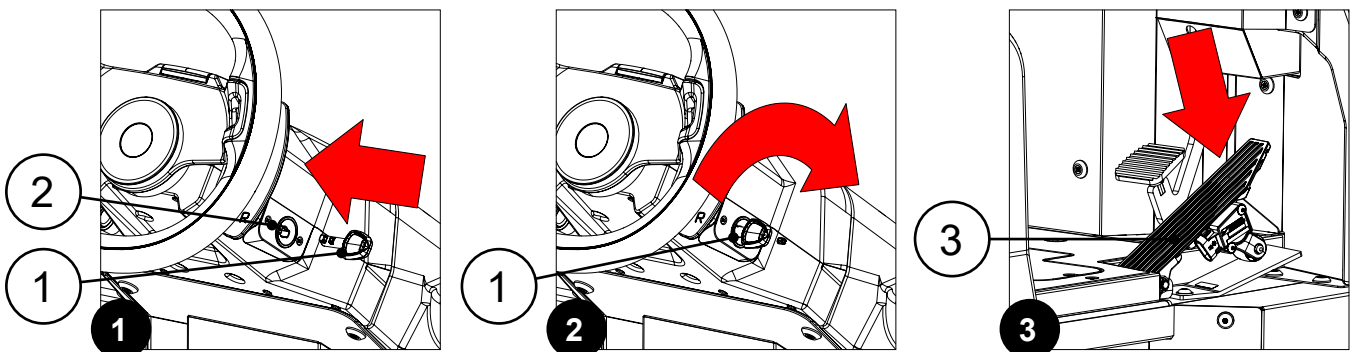

8. Once the sweeping brush head and side squeegee are in their working positions, set the main switch to its "0" position by turning the key (1) a quarter of a turn anti-clockwise (**Fig.4**).
9. Remove the key from the instrument panel.

10. Get off the machine.

CAUTION: do not position your foot above the side brush head carter while the machine is descending.

11. Grasp the handle (4) and turn the battery compartment carter (5) to its maintenance position (**Fig.5**).

ATTENTION: to prevent the lid from turning, insert the retainer (6) into the slot (7) (**Fig.6**).

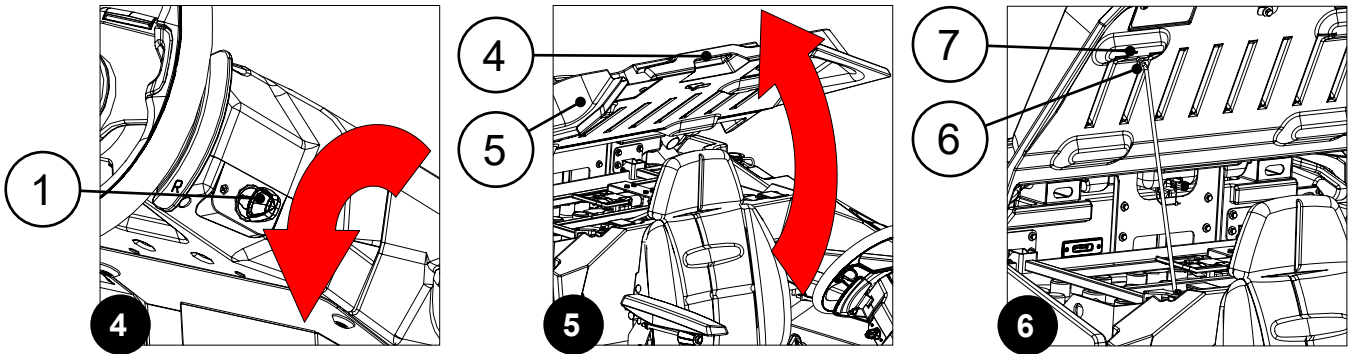

ATTENTION: the following operations must be carried out by qualified personnel. Incorrect operations could result in machine malfunctions.

12. Disconnect the machine's electrical system wiring connector (8) from the connector on the power cable coming from the battery box (**Fig. 7**).

13. Grasp the battery compartment lid and turn it to its working position.

N.B.: release the retainer before turning the lid.

CAUTION: it is recommended to wear the appropriate PPE (Personal Protective Equipment), suitable for the work to be carried out.

14. Go to the front left-hand side of the machine.

15. Open the left inspection door (9) (**Fig.8**).

16. Using the appropriate tools, not included along with the machine, loosen the retainer nut for the adjustment screw (10) (**Fig.9**).

17. Adjust the angle of the side brush with respect to the floor, screw or unscrew the screw (10) until the bristles of the brush are pressed against the floor by about two centimetres.

18. Once the adjustment is finished, tighten the counter nut.

19. Close the left inspection door (9) and repeat the above steps for the right side brush.

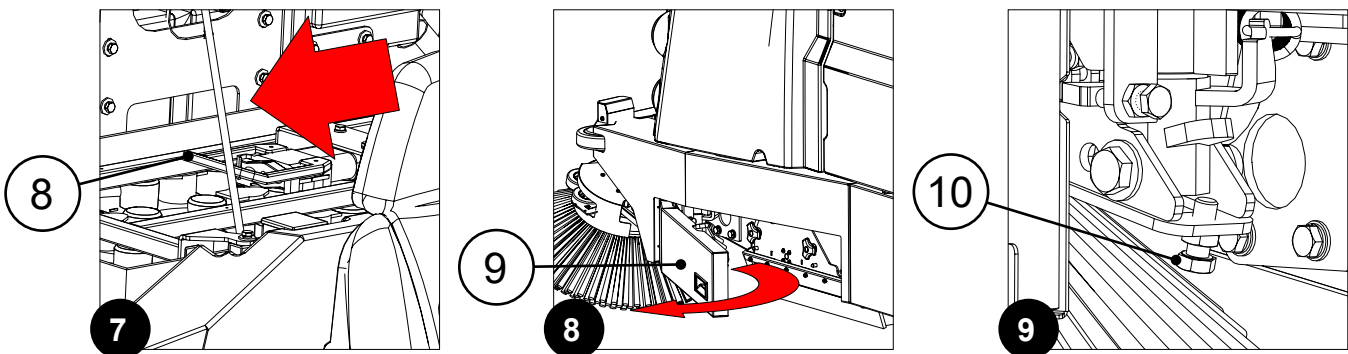

DISPOSAL

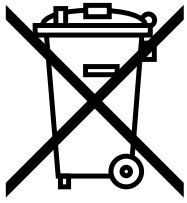

Fimap is committed to creating its products by respecting the environment, investing in the development of sustainable solutions and technologies, seeking materials that can easily be recycled, and ensuring that the entire production process has a low environmental impact.

At the end of the machine's life cycle, the Fimap provides the RECYCLING MANUAL (to be downloaded from the link <https://www.fimap.com/it/fimap/ambiente/33/riciclabilita.html>) to supply some simple information on the methods for disposing of the materials that make up your scrubbing machine.

Before proceeding with disposal, it is essential to contact your nearest authorised collection centres directly, in accordance with the legislation in force in the country where the machine is used.

CHOOSING AND USING BRUSHES

All the brushes are comprised of a body to which the various tufts of bristles are fixed. The brush bodies are generally made of plastic, as this is a material that ensures higher levels of reliability, in that it does not become damaged when wet.

i N.B.: when the bristle starts to be consumed, it comes closer to the brush and increases its rigidity, losing its flexibility characteristics that allows it to collect and remove dirt. For this reason it is important to replace them at the right moment.

The type of brushes for scrubbing machines can be chosen according to the material the bristles are made of; the most common bristle materials are as follows:

POLYPROPYLENE (PPL)	NYLON (PA)	TYNEX
Synthetic polymer	Synthetic polymer	Very durable abrasive material
Bristles with varying level of abrasion and thickness (0.3÷1.5 mm)	Can be used as an alternative to PPL	Can be used for deep cleaning on industrial surfaces
Can be used on any type of flooring		
Can be used for routine or deep cleaning		

UNION MIX	STEEL
Compound based on natural products	Suitable for industrial floors with stubborn dirt
Can be used for polishing and scrubbing activities	Alternative to Tynex
Resistant to very high temperatures	
Subject to rapid wear, shorter life than the PPL version	
Must be used with non-aggressive detergents	
Suitable for flooring types such as: marble; granite; porphyry cobbles; terracotta	
Not suitable for cleaning heavy soiling	

As an alternative to brushes, drive discs can be used. They consist of the rigid brush body without the bristles, which are replaced by pads.

PADS
Ideal for both regular and non-routine cleaning
Perfect for porcelain floors; tuff or microporous surfaces
Ideal for resin floors; cement floors; polishing operations
Not suitable for uneven floors with joints

BRUSHES OR DRIVE DISCS (DISCOID SCRUBBING VERSION)

Legend: \varnothing_E = external bristle diameter; \varnothing_F = external tank diameter (brush body)

CENTRAL BRUSH HEAD BRUSH TYPE

CODE	QTY	\varnothing EXTERNAL	TYPE OF BRISTLE	\varnothing BRISTLES	NOTES
405552	2	507 mm	PPL	0,3 mm	DISCOID BRUSH \varnothing_E 507mm \varnothing_F 485mm PPL 0.3mm (BLUE)
405553	2	507 mm	PPL	0,6 mm	DISCOID BRUSH \varnothing_E 507mm \varnothing_F 485mm PPL 0.6mm (WHITE)
405554	2	507 mm	PPL	0,9 mm	DISCOID BRUSH \varnothing_E 507mm \varnothing_F 485mm PPL 0.9mm (BLACK)
455600	2	507 mm	PPL	1,2 mm	DISCOID BRUSH \varnothing_E 507mm \varnothing_F 485mm PPL 1.2mm (BLACK)
405555	2	507 mm	TYNEX	1 mm	DISCOID BRUSH \varnothing_E 507mm \varnothing_F 485mm
405556	2	507 mm	NYLON	0,9 mm	DISCOID BRUSH \varnothing_E 507mm \varnothing_F 485mm
456306	2	507 mm	ABRASIVE	1,2 mm	DISCOID BRUSH \varnothing_E 507mm \varnothing_F 485mm
456307	2	505 mm			PAD HOLDER WITH CENTER LOCK

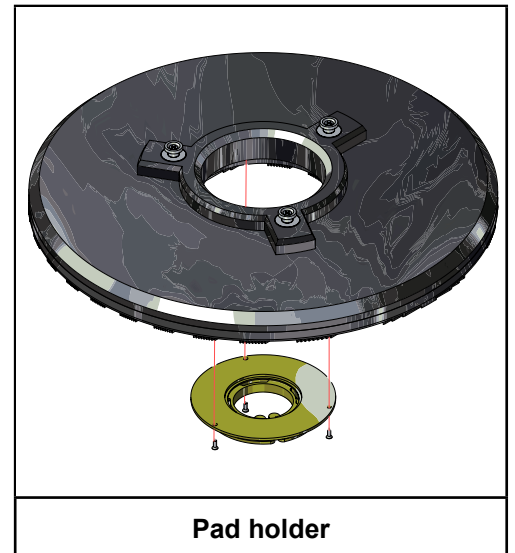
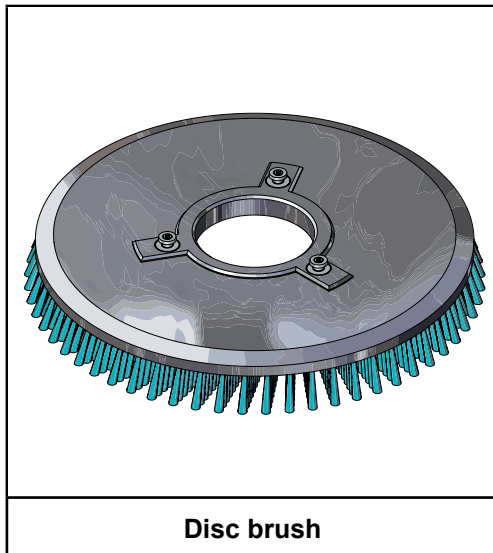

SIDE BRUSH HEAD BRUSH TYPE

CODE	QTY	\varnothing EXTERNAL	TYPE OF BRISTLE	\varnothing BRISTLES	NOTES
456466	1	355 mm	PPL	0,6 mm	DISCOID BRUSH \varnothing_E 355mm \varnothing_F 340mm PPL 0.6mm (WHITE)
456309	1	355 mm	PPL	0,9 mm	DISCOID BRUSH \varnothing_E 355mm \varnothing_F 340mm PPL 0.9mm (BLACK)
456310	1	355 mm	ABRASIVE	1 mm	DISCOID BRUSH \varnothing_E 355mm \varnothing_F 340mm ABRASIVE 1mm (GREY)
456311	1	340 mm			PAD HOLDER WITH CENTER LOCK

BRUSHES OR DRIVE DISCS (CYLINDRICAL SCRUBBING VERSION)

Legend: \varnothing_E = external bristle diameter; \varnothing_F = external tank diameter (brush body); L_E = maximum brush width (bristle reference); L_F = maximum brush width (tank reference);

CENTRAL BRUSH HEAD BRUSH TYPE

CODE	QTY	\varnothing EXTERNAL	TYPE OF BRISTLE	\varnothing BRISTLES	NOTES
456053	2	320	PPL	1	CYLINDRICAL BRUSH \varnothing_E 320mm \varnothing_F 115mm L_E 940mm L_F 973mm (BLACK)
456054	2	320	PPL	0,7	CYLINDRICAL BRUSH \varnothing_E 320mm \varnothing_F 115mm L_E 940mm L_F 973mm (WHITE)
456055	2	320	ABRASIVE	1.4	CYLINDRICAL BRUSH \varnothing_E 320mm \varnothing_F 115mm L_E 940mm L_F 973mm (GREY)
456527	2	320	PPL	1,2	CYLINDRICAL BRUSH \varnothing_E 320mm \varnothing_F 115mm L_E 940mm L_F 973mm (WHITE)
456528	2	320	PPL	1.5	CYLINDRICAL BRUSH \varnothing_E 320mm \varnothing_F 115mm L_E 940mm L_F 973mm (GREEN)

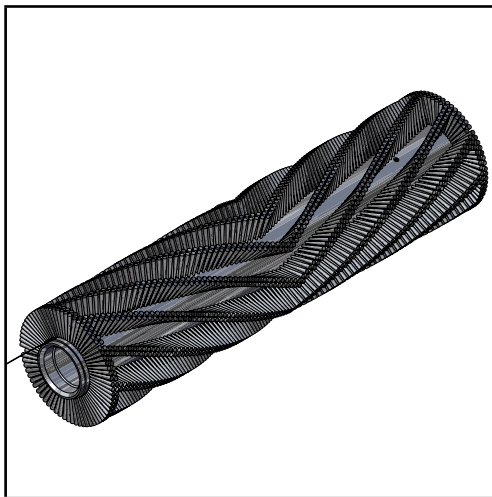

Cylindrical brush

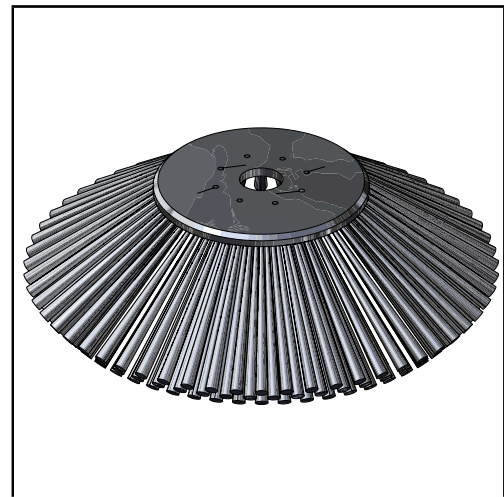

Disc brush (side)

SIDE BRUSH HEAD BRUSH TYPE

CODE	QTY	\varnothing EXTERNAL	TYPE OF BRISTLE	\varnothing BRISTLES	NOTES
456550	2	550	PPL	1.5	DISCOID BRUSH \varnothing_E 550mm \varnothing_F 250mm (WHITE)
456551	2	550	PPL + STEEL	1,1 + 0,7	DISCOID BRUSH \varnothing_E 550mm \varnothing_F 250mm (BLACK + STEEL FILAMENTS)
456552	2	550	PPL	1	DISCOID BRUSH \varnothing_E 550mm \varnothing_F 250mm (BLACK)

BRUSHES OR DRIVE DISCS (COMBINED VERSION)

Legend: \varnothing_E = external bristle diameter; \varnothing_F = external tank diameter (brush body); L_E = maximum brush width (bristle reference); L_F = maximum brush width (tank reference);

CENTRAL BRUSH HEAD BRUSH TYPE

CODE	QTY	\varnothing EXTERNAL	TYPE OF BRISTLE	\varnothing BRISTLES	NOTES
456654	2	240	PPL	0,3 + 0,7	CYLINDRICAL BRUSH \varnothing_E 240mm \varnothing_F 115mm L_E 810mm L_F 838mm (FRONT ROW, BLUE; REAR ROW, WAVY WHITE)
456140	2	240	PPL	0,7 + 1	CYLINDRICAL BRUSH \varnothing_E 240mm \varnothing_F 115mm L_E 810mm L_F 838mm (FRONT ROW WAVY WHITE; REAR ROW, MILLED BLACK)
456655	2	240	PPL + STEEL	0,7 + 0,5	CYLINDRICAL BRUSH \varnothing_E 240mm \varnothing_F 115mm L_E 810mm L_F 838mm (FRONT ROW WAVY WHITE; REAR ROW STEEL)

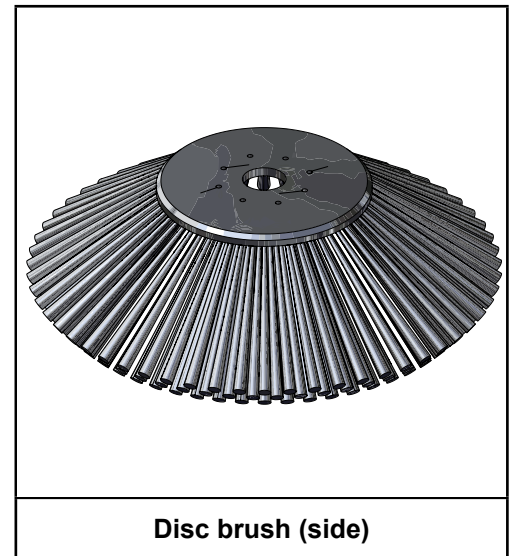
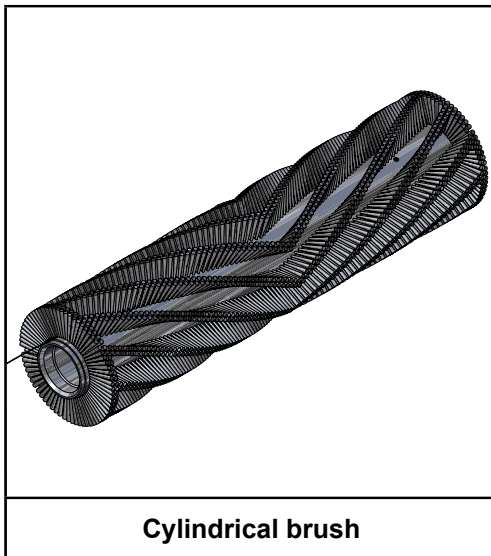

SIDE BRUSH HEAD BRUSH TYPE

CODE	QTY	\varnothing EXTERNAL	TYPE OF BRISTLE	\varnothing BRISTLES	NOTES
456550	2	550	PPL	1.5	DISCOID BRUSH \varnothing_E 550mm \varnothing_F 250mm (WHITE)
456551	2	550	PPL + STEEL	1,1 + 0,7	DISCOID BRUSH \varnothing_E 550mm \varnothing_F 250mm (BLACK + STEEL FILAMENTS)
456552	2	550	PPL	1	DISCOID BRUSH \varnothing_E 550mm \varnothing_F 250mm (BLACK)

TROUBLESHOOTING

This chapter lists the most common problems linked with the use of the machine. If you are unable to resolve the problems with the information given here, please contact your FIMAP service centre of reference, or that which is closest to you

THE MACHINE DOES NOT START

POSSIBLE CAUSE	SOLUTION
The main switch is set to "0".	Make sure that the main switch is in its "I" position, otherwise turn the key a quarter turn clockwise.
Check that when switched on there are no alarm messages on the command display.	Contact your FIMAP service centre of reference, or that which is closest to you.
Make sure the battery box is correctly connected and that the battery box connector is connected to the electrical system connector.	Make sure the batteries are properly connected to one another, contact your FIMAP service centre of reference, or that which is closest to you.
	Make sure the batteries are properly connected to the machine's electrical system, contact your FIMAP service centre of reference, or that which is closest to you.
Check the charge level of the battery box.	If the battery box charge level is critical, perform a complete charging cycle, see "RECHARGING THE BATTERY BOX" on page 42.

THE BATTERY BOX IS NOT COMPLETELY CHARGED

POSSIBLE CAUSE	SOLUTION
The battery charger cable connector is not properly inserted into the battery box connector.	Connect the battery charger cable connector to the battery box connector again.
The plug on the battery charger's power cable is not correctly inserted into the electrical outlet.	Check that the battery charger power supply cable plug is connected to the mains socket.
The characteristics of the mains power supply do not correspond to those required by the battery charger.	Check that the characteristics in the battery charger plate are the same as those of the mains supply.
The LEDs of the battery charger blink repeatedly.	Referring to the battery charger use and maintenance manual, check the meaning of the flashing signals that the battery charger emits during the battery recharge stage.
The electrolyte level in the battery box cells is low.	See the battery box user and maintenance manual to perform a top up. This document is supplied along with the battery box itself, or else can be obtained by contacting the battery box supplier.

THE MACHINE HAS A VERY LOW WORK AUTONOMY

POSSIBLE CAUSE	SOLUTION
Check the battery box charge level (check the symbol on the control display).	If the battery charge level is critical, perform a complete charging cycle, see "RECHARGING THE BATTERY BOX" on page 42.

THE MACHINE DOES NOT MOVE

POSSIBLE CAUSE	SOLUTION
The machine does not start.	See “THE MACHINE DOES NOT START” on page 167.
An error appears on the control display.	See “ALARM SCREEN” on page 93.
There is an issue on the drive pedal.	Contact your FIMAP service centre of reference, or that which is closest to you

INSUFFICIENT DETERGENT SOLUTION ON THE BRUSHES

POSSIBLE CAUSE	SOLUTION
The quantity of detergent solution in the water system is not sufficient for the work to be carried out.	Check that the amount of detergent solution present in the machine's water system is sufficient for the work to be carried out. If it is insufficient, see “DETERGENT SOLUTION” on page 46.
The amount of detergent solution delivered to the brushes is insufficient for the work that needs to be carried out.	Check that the amount of detergent solution delivered to the brushes is sufficient for the work to be carried out. If it is insufficient, see “ADJUSTMENT OF THE DETERGENT SOLUTION FLOW” on page 84.
	For the scrubbing versions, check that the delivery tube in the brush gearmotor is not blocked, if necessary, remove the blockage.
	For the scrubbing versions with side brush, check that the delivery tube in the brush gearmotor is not blocked, if necessary, remove the blockage.
Detergent solution filter obstructed.	For the cylindrical scrubbing versions, check that the delivery tube in the front part of the brush head body is not blocked, if necessary, remove the blockage.
	Check the detergent solution filter is not obstructed, otherwise clean it, see “CLEANING THE WATER SYSTEM FILTER” on page 123.
	Make sure that the automatic chemical detergent management system filter is not obstructed, otherwise clean it, see “CLEANING THE FILTER ON THE AUTOMATIC CHEMICAL DETERGENT MANAGEMENT SYSTEM (FSS VERSION)” on page 124.
	Make sure that the detergent solution recycling system filter is not obstructed, otherwise clean it, see “CLEANING THE FILTER ON THE DETERGENT SOLUTION RECYCLING SYSTEM (FLR VERSION)” on page 125.

THE MACHINE DOES NOT CLEAN CORRECTLY

POSSIBLE CAUSE	SOLUTION
The machine does not start.	See “THE MACHINE DOES NOT START” on page 167.
Not enough detergent solution comes out.	See “INSUFFICIENT DETERGENT SOLUTION ON THE BRUSHES” on page 168.

POSSIBLE CAUSE	SOLUTION
<p>The amount of detergent present in the water system of the machine is not sufficient for the work to be carried out.</p>	<p>For machine versions without the automatic chemical product management system, check the table in the detergent canister to verify the correct quantity to be introduced in the solution tank.</p>
	<p>For machine versions with the automatic chemical product management system, check the percentage of detergent selected for the work that you wish to carry out. To adjust, see “MODIFICA QUANTITÀ DI CHIMICO NEL SISTEMA DOSAGGIO AUTOMATICO DETERGENTE (SETTAGGI - DETERGENTE)” on page 19.</p>
<p>The brushes or drive discs being used are not properly inserted into the machine.</p>	<p>Check that the brushes are correctly inserted in the machine, if necessary see “ASSEMBLY OF BRUSHES OR DRIVE DISCS (DISCOID SCRUBBING VERSION)” on page 49.</p>
	<p>Check that the brush in the side brush head is properly inserted into the machine, if necessary see “ASSEMBLY OF THE SIDE BRUSH HEAD BRUSH OR DRIVE DISCS (DISCOID SCRUBBING VERSION)” on page 53.</p>
	<p>Check that the brushes in the brush head are correctly inserted in the machine, if necessary see “FITTING OF BRUSHES (CYLINDRICAL SCRUBBING VERSION)” on page 54.</p>
	<p>Check that the brush in the brush head is properly inserted into the machine, if necessary see “ASSEMBLY OF THE SIDE BRUSHES (CYLINDRICAL - COMBINED SCRUBBING VERSION)” on page 56.</p>
	<p>Check that the brushes in the brush head are correctly inserted in the machine, if necessary see “ASSEMBLY OF BRUSHES (COMBINED VERSION)” on page 57.</p>
<p>The type of brush used is not suitable for the dirt to be cleaned.</p>	<p>Check that the brushes installed on the machine are adequate for the work to be carried out, contact your FIMAP service centre of reference, or that which is closest to you</p>
<p>The brush bristles are excessively worn.</p>	<p>Check the state of wear of the brushes in the brush head and replace them if necessary, see “REPLACEMENT OF BRUSH HEAD DRIVE BRUSHES OR DISCS (DISCOID SCRUBBING VERSION)” on page 141.</p>
	<p>Check the state of wear of the brush in the side brush head and replace it if necessary, see “REPLACEMENT OF SIDE BRUSH HEAD DRIVE BRUSH OR DISCS (DISCOID SCRUBBING VERSION)” on page 144.</p>
	<p>Check the state of wear of the brushes in the brush head and replace them if necessary, see “REPLACING THE BRUSH HEAD BRUSHES (CYLINDRICAL SCRUBBING VERSION)” on page 148.</p>
	<p>Check the state of wear of the brush in the side brush head and replace it if necessary, see “REPLACEMENT OF THE SIDE BRUSH (CYLINDRICAL-COMBINED SCRUBBING VERSION)” on page 150.</p>
	<p>Check the state of wear of the brushes in the brush head and replace them if necessary, see “REPLACING THE SWEEPING BRUSH HEAD BRUSHES (COMBINED VERSION)” on page 151.</p>

POSSIBLE CAUSE	SOLUTION
The debris hopper is too full (cylindrical scrubbing version)	If the debris hopper is too full, empty it. See “EMPTYING THE DEBRIS HOPPER (CYLINDRICAL VERSION)” on page 79.
The debris hopper is too full (combined version)	If the debris hopper is too full, empty it. See “EMPTYING THE DEBRIS HOPPER (COMBINED VERSION)” on page 80.

THE SQUEEGEE DOES NOT DRY CORRECTLY

POSSIBLE CAUSE	SOLUTION
The vacuum unit is obstructed.	Make sure the squeegee is free of obstructions, see “CLEANING THE SQUEEGEE” on page 116.
	Check that the squeegee in the side brush is free from obstructions, if necessary see “CLEANING OF SIDE BRUSH HEAD SQUEEGEE (DISCOID SCRUBBING VERSION)” on page 130.
	Make sure the vacuum tube is free of obstructions, see “CLEANING THE SQUEEGEE VACUUM HOSE” on page 117.
	Check that the collection filter tray is free of obstructions, see “CLEANING THE COLLECTION FILTER TRAY” on page 119.
	Check that the wave protection tray is free of obstructions, see “CLEANING THE WAVE PROTECTION TRAY” on page 120.
	Check that the vacuum tube in the debris hopper is free from obstructions; if necessary see “CLEANING THE DEBRIS HOPPER (CYLINDRICAL SCRUBBING VERSION)” on page 132.
The rubber blades of the splash guard are dirty.	Check if the splash guards on the brush head are clean, see “CLEANING OF BRUSH HEAD SIDE SPLASH GUARD (DISCOID SCRUBBING VERSION)” on page 128.
	Check that the splash guard in the side brush head is clean, see “CLEANING OF SIDE BRUSH HEAD SPLASH GUARD (DISCOID SCRUBBING VERSION)” on page 129.
	Check if the splash guards on the brush head are clean, see “CLEANING OF BRUSH HEAD SIDE SPLASH GUARD (CYLINDRICAL SCRUBBING VERSION)” on page 132.
The squeegee rubber blades are dirty.	Check that the squeegee rubber blades are clean, see “CLEANING THE SQUEEGEE” on page 116.
	Check that the squeegee rubber blades in the side brush head are clean, see “CLEANING OF SIDE BRUSH HEAD SQUEEGEE (DISCOID SCRUBBING VERSION)” on page 130.
The cap on the recovery tank drainage tube is not properly positioned.	Check that the cap on the recovery tank drainage tube is positioned properly.
The recovery tank lid is not positioned correctly.	Check that the recovery tank lid is properly positioned on the machine.

EXCESSIVE FOAM PRODUCTION

POSSIBLE CAUSE	SOLUTION
The detergent being used is not suitable.	Check that a low foam detergent has been used. If necessary, add a small quantity of anti-foam liquid to the recovery tank.
The floor is not very dirty.	Dilute the detergent more.

THE MACHINE DOES NOT VACUUM CORRECTLY

POSSIBLE CAUSE	SOLUTION
The recovery tank is full.	Empty the recovery tank, see “DRAINING THE RECOVERY TANK” on page 121.
The vacuum device is obstructed	See “THE SQUEEGEE DOES NOT DRY CORRECTLY” on page 170.

EXCESSIVE DUST PRODUCTION (COMBINED VERSION)

POSSIBLE CAUSE	SOLUTION
Vacuum system disabled.	Check that the vacuum system of the debris hopper is not switched off; if it is, switch it on by pressing the button on the control display, see “VACUUM SYSTEM DEBRIS HOPPER PERFORMANCE ADJUSTMENT (COMBINED VERSION)” on page 86.
Clogged vacuum filter.	Check that the filter in the vacuum system is not clogged by dirt and clean if necessary; see “CLEANING THE DEBRIS HOPPER VACUUM FILTER (COMBINED VERSION)” on page 136.
The debris hopper is too full	Check that the debris hopper is not full; if necessary, empty it. See “EMPTYING THE DEBRIS HOPPER (COMBINED VERSION)” on page 80.
Dust seal flaps no longer in good condition	Contact your FIMAP service centre of reference, or that which is closest to you.

EC DECLARATION OF CONFORMITY



The undersigned manufacturer:

FIMAP S.p.A.
Via Invalidi del Lavoro, 1
37059 Santa Maria di Zevio (VR)

declares under its sole responsibility that the products

FLOOR SCRUBBING MACHINES

mod. GMG B PLUS; GMG BS PLUS

comply with the requirements of the following Directives:

- 2006/42/EC: Machinery Directive.
- 2014/30/EU: Electromagnetic compatibility directive.

The person authorized to compile the technical file:

Mr. Giancarlo Ruffo
Via Invalidi del Lavoro, 1
37059 Santa Maria di Zevio (VR) - ITALY

Santa Maria di Zevio (VR), 18/03/2022

FIMAP S.p.A.
Legal representative
Giancarlo Ruffo

The undersigned manufacturer:

FIMAP S.p.A.
Via Invalidi del Lavoro, 1
37059 Santa Maria di Zevio (VR)

declares under its sole responsibility that the products

SWEEPING MACHINES

mod. GMG BC PLUS

comply with the requirements of the following Directives:

- 2006/42/EC: Machinery Directive.
- 2014/30/EU: Electromagnetic compatibility directive.
- 2000/14/EC: Directive by the European Parliament and Council date 8th May, 2000. Noise emission by machines and equipment for outdoor use.

MODEL	LwA [dB(A)]	LwA guaranteed [dB(A)]
GMG BC PLUS	92,2	92,2

The person authorized to compile the technical file:

Mr. Giancarlo Ruffo
Via Invalidi del Lavoro, 1
37059 Santa Maria di Zevio (VR) - ITALY

Santa Maria di Zevio (VR), 18/03/2022

FIMAP S.p.A.
Legal representative
Giancarlo Ruffo

UKCA DECLARATION OF CONFORMITY

The undersigned manufacturer:

FIMAP S.p.A.
Via Invalidi del Lavoro, 1
37059 Santa Maria di Zevio (VR)

declares under its sole responsibility that the products

FLOOR SCRUBBING MACHINES

mod. GMG B PLUS; GMG BS PLUS

comply with the requirements of the following Directives:

- S.I. 2008/1597 Supply of Machinery (Safety) Regulations 2008 (as amended).
- S.I. 2016:1091 Electromagnetic Compatibility Regulations 2016 (as amended).

The person authorized to compile the technical file:

Mr. Giancarlo Ruffo
Via Invalidi del Lavoro, 1
37059 Santa Maria di Zevio (VR) - ITALY

Santa Maria di Zevio (VR), 18/03/2022

FIMAP S.p.A.
Legal representative
Giancarlo Ruffo

The undersigned manufacturer:

FIMAP S.p.A.
Via Invalidi del Lavoro, 1
37059 Santa Maria di Zevio (VR)

declares under its sole responsibility that the products

SWEEPING MACHINES

mod. GMG BC PLUS

comply with the requirements of the following Directives:

- S.I. 2008/1597 Supply of Machinery (Safety) Regulations 2008 (as amended).
- S.I. 2016:1091 Electromagnetic Compatibility Regulations 2016 (as amended).
- S.I. 2001:1701 Noise Emission in the Environment by Equipment for use Outdoors Regulations 2001 (as amended).

MODEL	LwA [dB(A)]	LwA guaranteed [dB(A)]
GMG BC PLUS	92,2	92,2

The person authorized to compile the technical file:

Mr. Giancarlo Ruffo
Via Invalidi del Lavoro, 1
37059 Santa Maria di Zevio (VR) - ITALY

Santa Maria di Zevio (VR), 18/03/2022

FIMAP S.p.A.
Legal representative
Giancarlo Ruffo



FIMAP S.p.A.

✉ Via Invalidi del Lavoro, 1
37059 S. Maria di Zevio (VR)

Italy

☎ +39 045 6060491 - 📠 +39 045 6060440

@ service@fimap.com 🌐 www.fimap.com